



Joyce/Dayton Corp.

Operation and Maintenance Manual for

Joyce/Dayton Linear Actuator

1500 Pound Capacity DC Actuator, LA152L, and LA152C

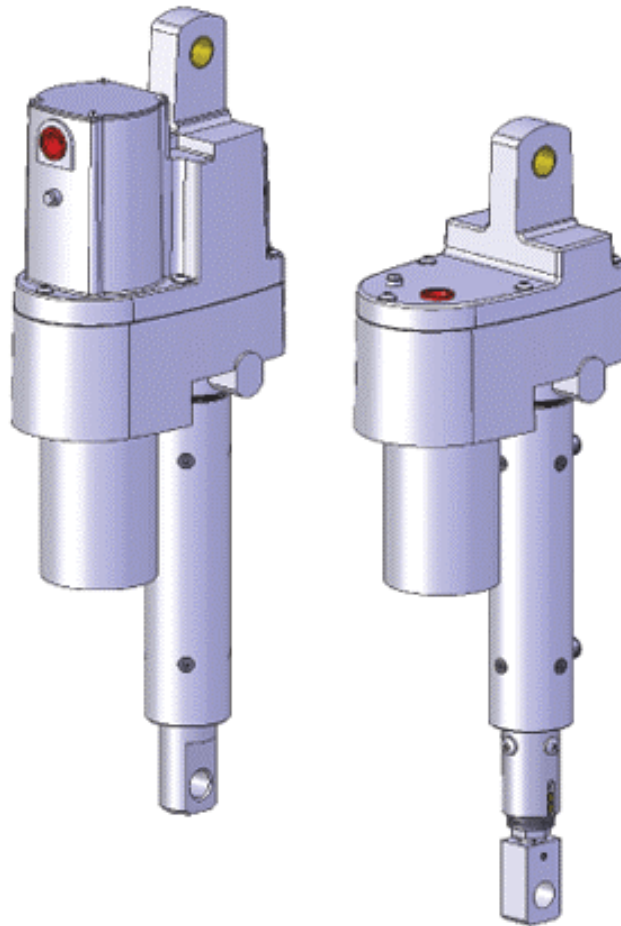

WARNING!

The recommendations in this manual for installation, operation and maintenance must be followed to ensure safe use. All persons responsible for the installation and use of Joyce/Dayton Linear Actuators must be familiar with the contents of this manual.

Customer is responsible for guards and other protective devices and ensuring that Linear Actuator usage conforms with local and national operating and safety codes appropriate to the class of equipment into which the Linear Actuator is installed.

Table of Contents

Section I – General Information

1-1 Contacting Joyce Dayton.....	3
1-2 Purpose and Scope	3
1-3 Receipt of Product	3
1-4 Warranty	3
1-5 Precautions for Use and Installation	3
1-6 General Installation Instructions	4
1-7 Limit Switch Adjustment - Initial	4
1-8 Limit Switch Adjustment – Fine.....	5
1-9 Final Travel of Actuator	5

Section II – Maintenance

2-1 Lubrication.....	6
2-2 Repair Parts	6
2-3 Disassembly of Linear Actuator.....	6
2-4 Assembly of Linear Actuator	7

Section III – Views and Parts Lists

3-1 Exploded View with Limit Switch	8
3-2 Parts List for Linear Actuator with Limit Switch	9
3-3 Exploded View with Clutch.....	10
3-4 Parts List for Linear Actuator with Clutch	11

Section IV – Technical Drawings and Illustrations

4-1 Wiring Diagrams.....	12
4-2 Limit Switch	13
4-3 Brake Assembly Diagram	14
4-4 Travel Limit Chart.....	14

Section V – Part Numbers, Ordering and Maintenance Log

5-1 Order Information.....	15
5-2 Maintenance Log.....	16

Section I General Information

1-1 Contacting Joyce/Dayton Corp.

Joyce/Dayton Corp.
P.O. Box 1630
Dayton, OH 45401
(800) 523-5204 (US and Canada only)
(937) 294-6261 (937) 297-7173 Fax
Email: sales.jacks@joycedayton.com
Website: www.joycedayton.com

1-2 Purpose and Scope

This manual provides installation, operation and maintenance instruction for the standard 1500 pound capacity Joyce/Dayton Linear Actuator. Although this manual covers the standard Linear Actuators, some may vary significantly from this manual. For special units not covered, please contact Joyce/Dayton Corp. for assistance.

1-3 Receipt of Product

All equipment should be immediately inspected upon receipt for any damage and to verify correct product and quantities. Any problems should be reported to Joyce/Dayton Corp. and the freight carrier as soon as possible. Products returned without a *Return Goods Authorization (RGA)* form will not be accepted.

1-4 Warranty

Seller warrants its products to be free from defects in material and workmanship under normal and proper use in accordance with instruction of seller for a period of one year from the date of shipment to buyer. Seller's liability under such warranty or in connection with any other claim relating to the products shall be limited to the repair, or at seller's option, the replacement or refund of the purchase price, of any products or parts or components thereof which are returned to seller freight prepaid and which are defective in material or workmanship. Products or parts or components thereof which are repaired or replaced by seller will be returned to buyer freight collect. This warranty is not intended to cover consumer products, as defined in the Magnuson-Moss Warranty-Federal Trade Commission Improvement Act, 15 U. S. C. Sections 2301-12, which are purchased by buyer for purposes other than resale. If buyer is not intending to resell the products, and if the products are consumer products as defined in the Magnuson-Moss Act, the foregoing warranty, but not the limitation of seller's liability, shall be null and void. EXCEPT AS EXPRESSLY STATED ABOVE, SELLER MAKES NO WARRANTY, EXPRESS OR IMPLIED, WHETHER OF MERCHANTABILITY OR FITNESS FOR ANY PARTICULAR PURPOSE OR USE OR OTHERWISE, ON THE PRODUCTS, OR ON ANY PARTS OR LABOR FURNISHED DURING THE SALE, DELIVERY OR SERVICING OF THE PRODUCTS.

1-5 Precautions of Use and Installation

1. Travel is limited on some DC Linear Actuators by using the limit switches which are provided as an option. On DC Linear Actuators that are equipped with limit switches it is imperative that they be set within the designed limits of the Linear Actuator. Exceeding the design limits can cause damage to the internal linear actuator mechanism. Follow the procedure in Sections 1-7 and 1-8 of this manual.
2. In most applications, factory or manufacturer-assisted installation is not required. However, it is necessary that appropriate, qualified personnel perform the installation of Joyce/Dayton products.
3. Joyce/Dayton Linear Actuators are not rated for shock-loading or extreme vibration. It is the responsibility of the user to ensure these conditions are not imposed on the actuator.
4. In the event that service or maintenance is required, the load must be secured or removed before any work can begin.

5. The Linear actuators can be mounted and operated in any orientation. Standard Linear actuators will come with all holes plugged. Follow the procedure in Section 1-9 to properly plug or vent the holes to prevent dirt and moisture from contaminating the actuator.
6. Never allow the actuator to retract beyond the minimum closed position or extend beyond the maximum open position, as damage to the unit can occur. Refer to the Travel Limit Chart provided in Section 4-4 for a list of dimensional limits.
7. The clutch is factory preset and should need no adjustment in the field.
8. External temperature may reach 230 Degrees F. near maximum duty cycle. Use caution to prevent personal injury.
9. Do not use actuator in applications where the unit can be jammed; that is, where the limits can be over-traveled or the linear actuator can be pressed against an immovable object.

1-6 General Installation Instructions

1. Ensure that all personnel who will service or operate equipment are familiar with its use and limitations.
2. Secure or remove the load before any installation procedures begin.
3. Be certain the rating of the actuator meets or exceeds the load.
4. The actuator must be mounted on a rigid structure sufficient to support the maximum possible load. An under-designed structure could lead to premature wear or failure.
5. When fastening the load to an actuator, make sure the actuator is in the retracted position. This positions the load accurately with respect to the lifting screw centerline. Never pull the translating tube to one side to make connection with your structure. Fully extend the actuator to make sure the load is aligned with the translating tube.
6. Limit switches are NOT pre-set. They require field adjustment before use. (See Section 1-7 and Section 1-8.)

1-7 Limit Switch Adjustment – Initial Adjustment Procedure

1. The travel limits must not be exceeded when setting the limit switches.
This means that you do not want to set the extended or the retracted position beyond the designed travel limits of the unit.
2. Remove the screws (45), switch cover (60), and switch cover gasket (59).
3. Rotate both Limit Switch Nut Cams (54) toward the center of the threaded shaft (53) to clear the switches.
4. Rotate the translating tube (31) until the distance between both clevis eyes equals the minimum closed dimension you require. This can be fine adjusted via the slot at the end of the motor. **Do not exceed the designed travel limits of the unit.** Refer to the Travel Limit Chart in Section 4-4.
5. If the clevis holes are not properly aligned, use a screwdriver to rotate the motor (3) and drive the translating tube (31) to its proper retracted position.
6. Now adjust the limit switch nut cam (54) that controls the retracted limit. This switch has a red electrical lead attached to it. To make this adjustment, rotate both limit switch nut cams together on the threaded shaft until the switch is activated. You will see the switch lever depress and hear it “click” when it is activated.
7. Temporarily insert the cam nut retainer (56) into the proper slots in the limit switch cavity and in the slots in the limit switch nut cams (54). Using a marking pen, mark the slot on the limit switch nut cam which controls the lower limit switch. **Do not mark the upper cam at this time.** Use screw (45) to install the limit switch gasket and cover (59, 60) to hold the cam nut retainer (56) in place.
8. Next, extend the jack to the upper limit position. This will need to be done electrically or with a screwdriver through the electric motor. **Do NOT rotate the translating tube (31).** (Make sure the two clevis ends are oriented properly.) The extended position is the maximum distance between the two clevis eyes. **Do not exceed the designed travel limits of the unit.** Refer to the Travel Limit Chart in Section 4-4.
9. Remove the Limit switch gasket and cover (59, 60) and cam nut retainer (56). Use care not to disturb the position of the lower limit switch nut cam (54).

10. Now adjust the upper limit switch nut cam (54) which is nearest the translating tube (31) and controls the extended position. This switch has a black lead on it. Rotate this cam until the switch is activated. You will see the switch lever depress and hear it “click” when it is activated.
11. Insert the cam nut retainer (56) into the marked slot (for the lower setting) and the slot closest to the position you have set (for the upper setting). Using a marking pen, mark the slot on the cam for the upper limit setting.
12. Replace the limit switch gasket and cover (59, 60) using screws (45).
13. The travel limits are now set to their initial settings. Activate the motor to check for proper adjustment. Sometimes after installing this actuator in your application, a fine adjustment is required on the limit switches. To achieve the fine adjustment, follow the procedure outlined below.

1-8 Limit Switch Adjustment – Fine Adjustment Procedure

1. Remove the limit switch gasket and cover and cam nut retainer (59, 60 and 56). You will see the cams that you marked for position. Each notch on the limit switch nut cam is equal to approximately .050 inch of screw travel. By rotating the limit switch nut cams you can fine-tune the limit settings.

Viewing the Limit switch cavity with the lifting screw and gearbox on your right the following adjustments can be made:

2. To retract the translating tube (31) more, that is to shorten the distance between the clevis eyes, rotate the limit switch nut cam away from the switch lever. This activates the switch with the red leads. **Note: It is critical that you are not setting the limit beyond the minimum travel of the actuator.** Refer to the Travel Limit Chart in Section 4-4.
3. To extend the lower limit, that is to increase the distance between the clevis eyes, rotate the limit switch nut cam toward the switch lever. This activates the switch with the red leads.
4. To shorten the maximum travel; so the travel is slightly less at the extended position, rotate the left-hand limit switch nut cam toward the switch with the black leads.
5. To extend the upper limit so the travel is slightly greater, rotate the left-hand limit switch nut cam away from the switch. This activates the switch with the black leads. **Note: It is critical that you are not setting the limit beyond the maximum travel of the actuator.** Refer to the Travel Limit Chart in Section 4-4.
6. When the fine adjustment is complete, insert the cam nut retainer (56) into the closest slot and mark with a marking pen. Note: The cam nut retainer may now be inserted in notches other than those you previously marked.
7. Replace the limit switch gasket and cover using the correct fasteners.
8. Activate the actuator electrically to test the limit switch stops. The adjustment procedure can be repeated as needed.

1-9 Final Travel of Actuator

1. Check the drift by extending and retracting the actuator, electrically.
2. Make small adjustments in the limit switch setting by following steps outlined in Section 1-8.
3. Now you can install the actuator in your application.
4. Place the air vent in the correct orientation based on the application and mounting position of the actuator. In a vertical application, the vent may be placed in any of the available holes. If the Linear Actuator is mounted horizontally, install the vent on one of the sides, i.e.: not the lowest position. Place the vent on a side that is most accessible for servicing.

Section II Maintenance

2-1 Lubrication

1. Actuators are lubricated before leaving the factory and under normal operating conditions are lubricated for life.
2. The upper and lower housing cavities are lubricated with Mobile AW1 grease, or equivalent.
3. The lifting screw and translating tube assembly are lubricated with Exxon Ronex Extra Duty 1 grease, or equivalent.
4. The spring brake assembly is lubricated with Mobilith AW 1 grease, or equivalent.
5. The products listed are recommended by the lubricant manufacturers to meet the requirements for normal operation. The listing of brand names is solely for the convenience of users of Joyce equipment and their lubricant suppliers; it does not constitute any endorsement. Joyce/Dayton assumes no responsibilities for the quality, performance or availability of any listed products.

Upper and Lower Housing Cavities	Mobilith AW1
Spring Brake Assembly	Mobilith AW1
Translating Tube Assembly	Exxon Ronex Extra Duty 1

2-2 Repair Parts

Repair parts may be obtained by calling Joyce/Dayton Customer Service at (800) 523-5204, or (937) 294-6261, (937) 297-7173 (facsimile) or your local sales representative. When ordering repair parts please supply the jack description (i.e., LA155L-12), and the serial number. A Maintenance Log can be found in section 5-2.

The following parts are recommended for rebuild or spares. A complete list of parts is available in Sections 3-1, 3-2, 3-3, and 3-4.

- A. (1) Motor 3
- B. (1) Motor Coupling Kit 6, 7, 8, 9, and 10
- C. (1) Miniature Bearing 11
- D. (1) Miniature Bearing 13
- E. (2) Thrust Washer 14
- F. (4) Thrust Bearing 18
- G. (1) Woodruff Key 23
- H. (1) Seal 33 or 37
- I. (1) Gasket 36 or 38
- J. (1) Limit Switch Insulation 48
- K. (2) Limit Switch 49
- L. (1) DC Translating Tube Assembly with Clevis end (18040011) or
- M. (1) DC Translating Tube Assembly with Threaded end (18040026) or
- N. (1) DC Translating Tube Assembly with Clevis and Clutch (18030079) or
- O. (1) DC Translating Tube Assembly with Clutch Assembly ((18040027) or

2-3 Disassembly of Linear Actuator

Motor Disassembly

1. The motor included with the Linear Actuator is not user-serviceable.
2. Disconnect power from the Actuator before proceeding.
3. To remove the motor, secure the Linear Actuator in a work holding device such as a bench vise. Do not clamp on the outer tube (32 or 35) or the upper housing (2).
4. Remove the screws, washers and gasket (38, 39, and 36) or (40, 41, and 38).
5. If equipped with a limit switch, remove the screws, cover and gasket (45, 60, and 59) to open the limit switch cavity.

6. Remove the screws and washers (38, 39) from the upper housing (2).
7. Set these aside and carefully remove the upper housing. (It may require effort to pull the upper and lower housings apart.)
8. Remove the nuts and lock washers (65, 66) or (51, 52) that attach the motor to the lower housing (1).
9. Disconnect the motor lead wires from the limit switch and feed the motor lead wires through the housing .
10. Remove the motor (3).
11. Replace any worn or damaged parts upon re-assembly.

2-4 Assembly of Linear Actuator

Assemble Limit Switches

1. When assembling these parts, take care not to damage the small limit switches by bending the metal plungers or by overextending them.
2. Insert the limit switch insulation in the limit switch cavity. Using a flat bit screwdriver and two screws (50), attach the limit switch assembly (49, 51, 52) snugly to the back of the limit switch cavity.
3. Assemble the Limit Switch Nut Cams (54) to the Limit Switch Shaft (53). It may be best to rotate them toward the center of the shaft to protect the switches from being bent or overextended
4. Check that the slot in the end of the screw is aligned vertically to the switches. If it is not so aligned, rotate through the motor using a screwdriver in the motor slot until the alignment is correct.
5. Insert the compression spring (42) into the cavity recess at the slotted end of the lifting screw.
6. Insert the flat end of the shaft assembly (53, 54, 55, 68) into the slot on top of the compression spring (42) and rounded end into the bronze bearing (55) on the opposite side of the cavity.
7. Insert the cam nut retainer (56) into the grooves on the edges of the limit switch cavity. If this unit includes a potentiometer it will be attached to the cam nut retainer (56). The potentiometer is optional and your unit may not have one.
8. The small pinion on the potentiometer will mesh with the potentiometer worm (68).
Caution: it is possible to damage the potentiometer by “jamming” it beyond the intended number of pinion rotations in a single direction. Follow the procedure for setting the limit switches before operating the linear actuator. Refer to Section 1-7 and Section 1-8.
9. Cover the limit switch cavity using the four screws (45) and the gasket and switch cover (59, 60).

Capacitor Cavity

10. The capacitor cavity adjoins the limit switch cavity and provides a wiring access hole. Various wiring will need to be carefully routed through this cavity to the access hole on the other side. Keep this in mind when attaching the electrical leads to and from the limit switches, potentiometer, motor, and capacitor.
11. Using the wiring diagram in Section 4-1, and this manual, connect the various wires and pass the leads through the capacitor cavity and out the access hole.
12. Double-check all electrical connections before attaching the gasket (43) and the cover (44) with screws (45).

Section III Views and Part Lists

3-1 Exploded View - Linear Actuator with Limit Switch

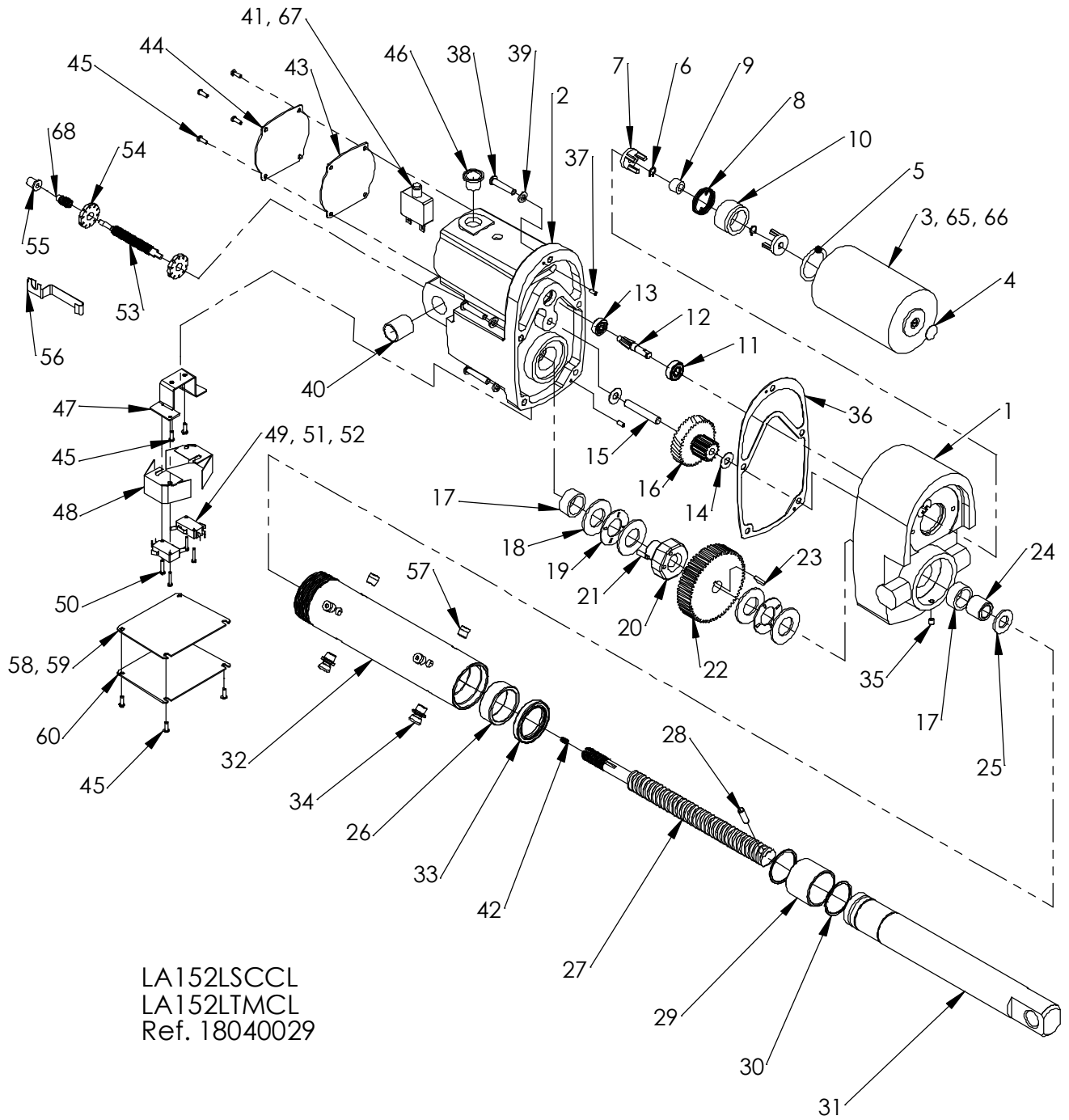

3-2 Linear Actuator with Limit Switch (18040029)

Table 3-2 Parts List

Item		Item	
1	DC Lower Housing (1)	36	Gasket (1)
2	DC Upper Housing (1)	37	Dowel Pin (2)
3	Motor (1)	38	Screw (5)
4	Hole Plug (1)	39	Lock Washer (5)
5	O-Ring (1)	40	Upper Bushing (1)
6	Retaining Ring (1)	41	Circuit Breaker (1)
7	Coupling Half (2)	42	Compression Spring (1)
8	Drive Spring (2)	43	Cover Gasket (1)
9	Rubber Grommet (1)	44	Cover (1)
10	DC Insert (1)	45	Screw (10)
11	Miniature Bearing – 8mm (1)	46	Tapered Plug (1)
12	Input Pinion(1)	47	Limit Switch Bracket
13	Miniature Bearing – 6mm (1)	48	Limit Switch Insulation (2)
14	Thrust Washer (2)	49	Limit Switch (2)
15	Dowel Pin (1)	50	Screw (4)
16	Cluster Gear (1)	51	Red Jumper Wire (2)
17	Casting Bushing (2)	52	Black Jumper Wire (2)
18	Thrust Washer (4)	53	Limit Switch Shaft (1)
19	Thrust Bearing (2)	54	Limit Switch Nut Cam (2)
20	Spacer Nut (1)	55	Bronze Bearing, Flanged (1)
21	Set Screw (1)	56	Cam Nut Retainer (1)
22	Output Gear (1)	57	Pipe Plug (4)
23	Woodruff Key (1)	58	Instruction Decal (1)
24	Gear Spacer (1)	59	Limit Switch Gasket (1)
25	Washer (1)	60	Limit Switch Cover (1)
26	Guide Bearing (1)	61	Warning decal (1)
27	Lifting Screw (1)	62	Large Decal (1)
28	Dowel Pin (1)	63	Name Tag (1)
29	Translating Tube Bushing (1)	64	Drive Screw (2)
30	Retaining Ring (2)	65	Hex Nut (2)
31	Translating Tube Assembly (1)	66	Lock Washer (2)
32	Outer Tube (1)	67	Female Disconnect (1)
33	Seal (1)	68	Worm, Potentiometer (1)
34	Air Vent (2)		
35	Set Screw (1)		

3-3 Exploded View - Linear Actuator with Clutch (18030091)

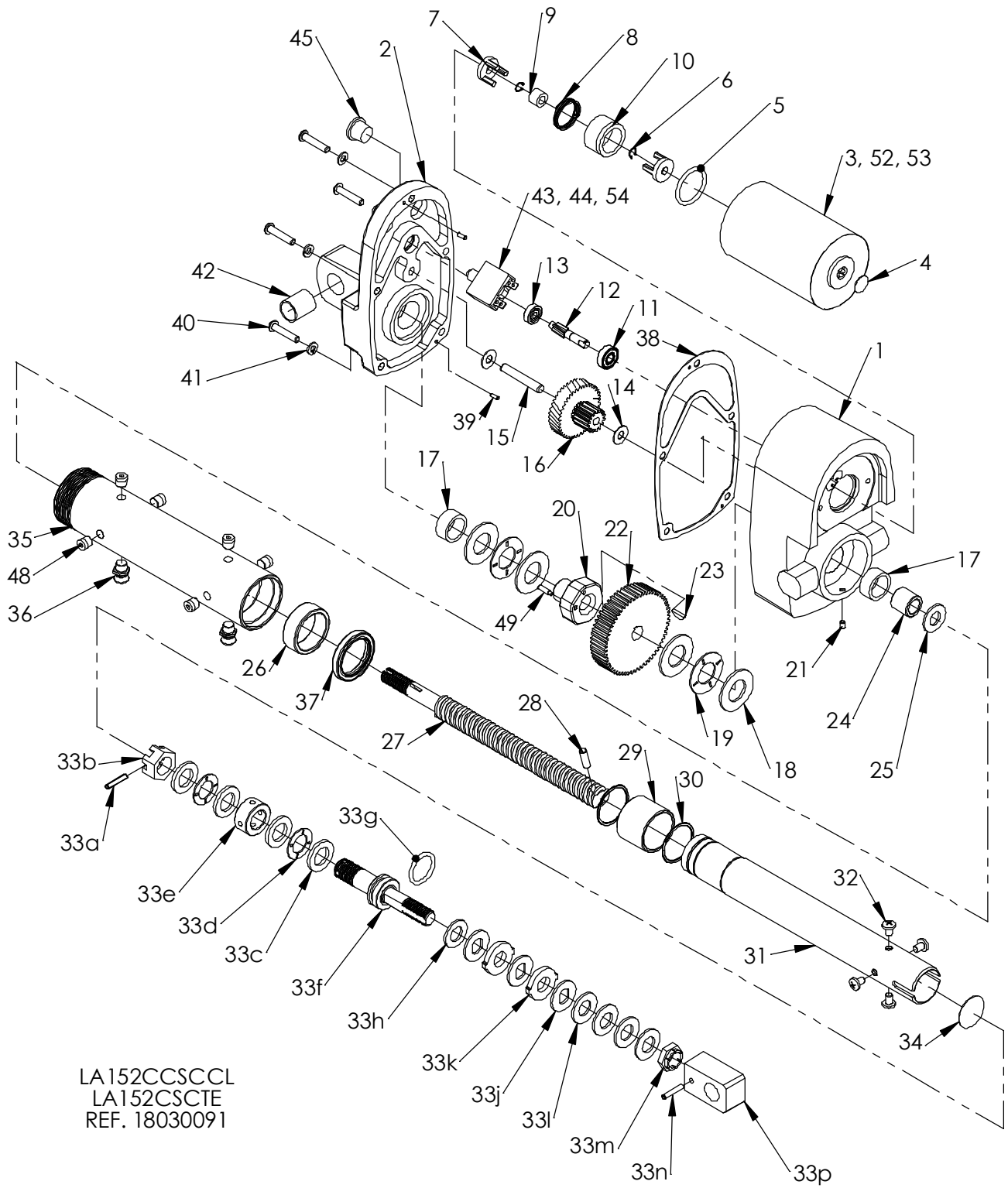

3-4 Parts List - Linear Actuator with Clutch (18030091)

Table 3-4 Parts List

Item		Item	
1	DC Lower Housing (1)	36	Air Vent (2)
2	DC Upper Housing (1)	37	Seal (1)
3	Motor (1)	38	Gasket (1)
4	Hole Plug (1)	39	Dowel Pins (2)
5	O-Ring (1)	40	Screw (5)
6	Retaining Ring (1)	41	Lock Washer (5)
7	Coupling Half (2)	42	Upper Bushing (1)
8	Drive Spring (2)	43	Circuit Breaker (1)
9	Rubber Grommet (1)	44	Jumper Wire (1)
10	DC Insert (1)	45	Tapered Plug (1)
11	Miniature Bearing – 8mm (1)	46	Warning Decal (1)
12	Input Pinion(1)	47	Large Decal (1)
13	Miniature Bearing – 6mm (1)	48	Pipe Plug (4)
14	Thrust Washer (2)	49	Screw (1)
15	Dowel Pin (1)	50	Name Tag (1)
16	Cluster Gear (1)	51	Drive Screw (2)
17	Casting Bushing (2)	52	Hex Nut (2)
18	Thrust Washer (4)	53	Lock Washer (2)
19	Thrust Bearing (2)	54	Female Disconnect (1)
20	Spacer Nut (1)		
21	Set Screw (1)		
22	Output Gear (1)		
23	Woodruff Key (1)		
24	Gear Spacer (1)		
25	Washer (1)		
26	Guide Bearing (1)		
27	Lifting Screw (1)		
28	Dowel Pin (1)		
29	Translating Tube Bushing (1)		
30	Retaining Ring (2)		
31	Translating Tube Assembly (1)		
32	Screw (4)		
33	Slip Clutch Assembly (1)		
34	Expansion Plug (1)		
35	Outer Tube (1)		

Section IV Technical Drawings and Illustrations

4-1 Wiring Diagrams

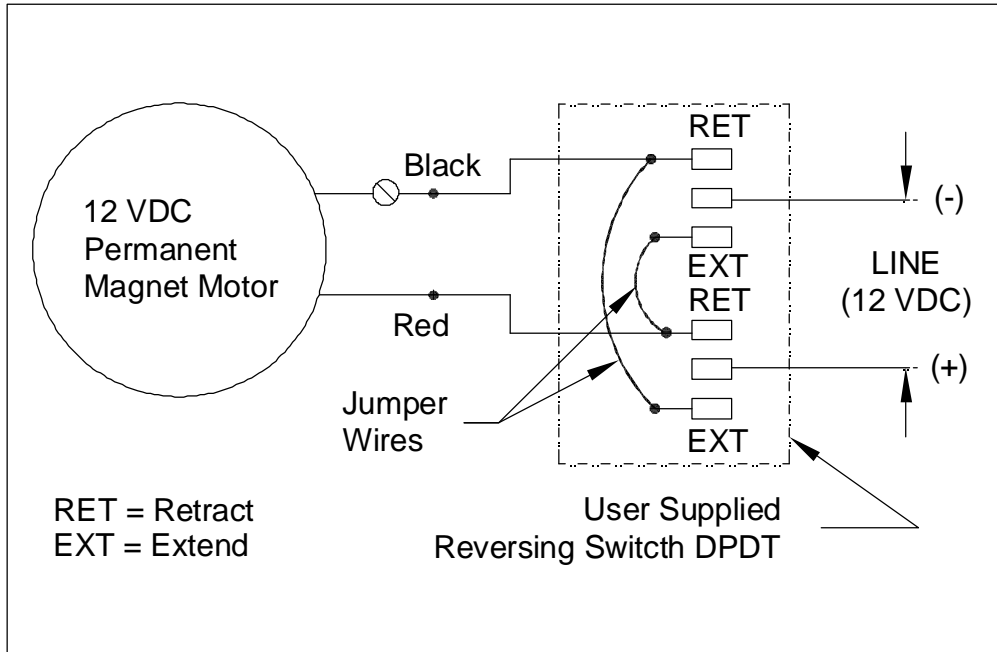

LA152C Actuator

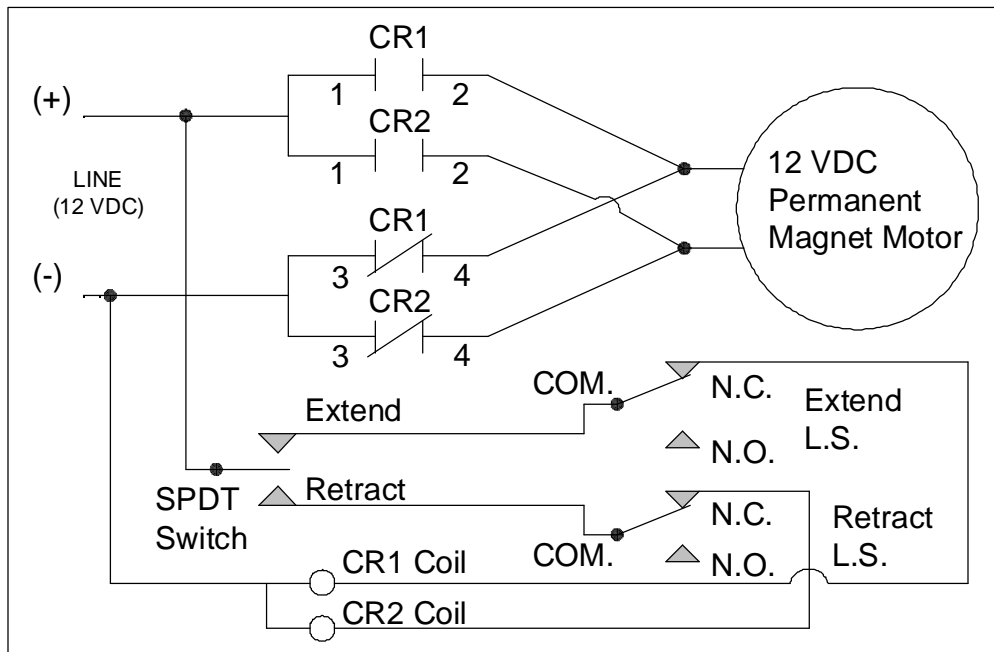

LA152L Actuator

4-2 Limit Switch

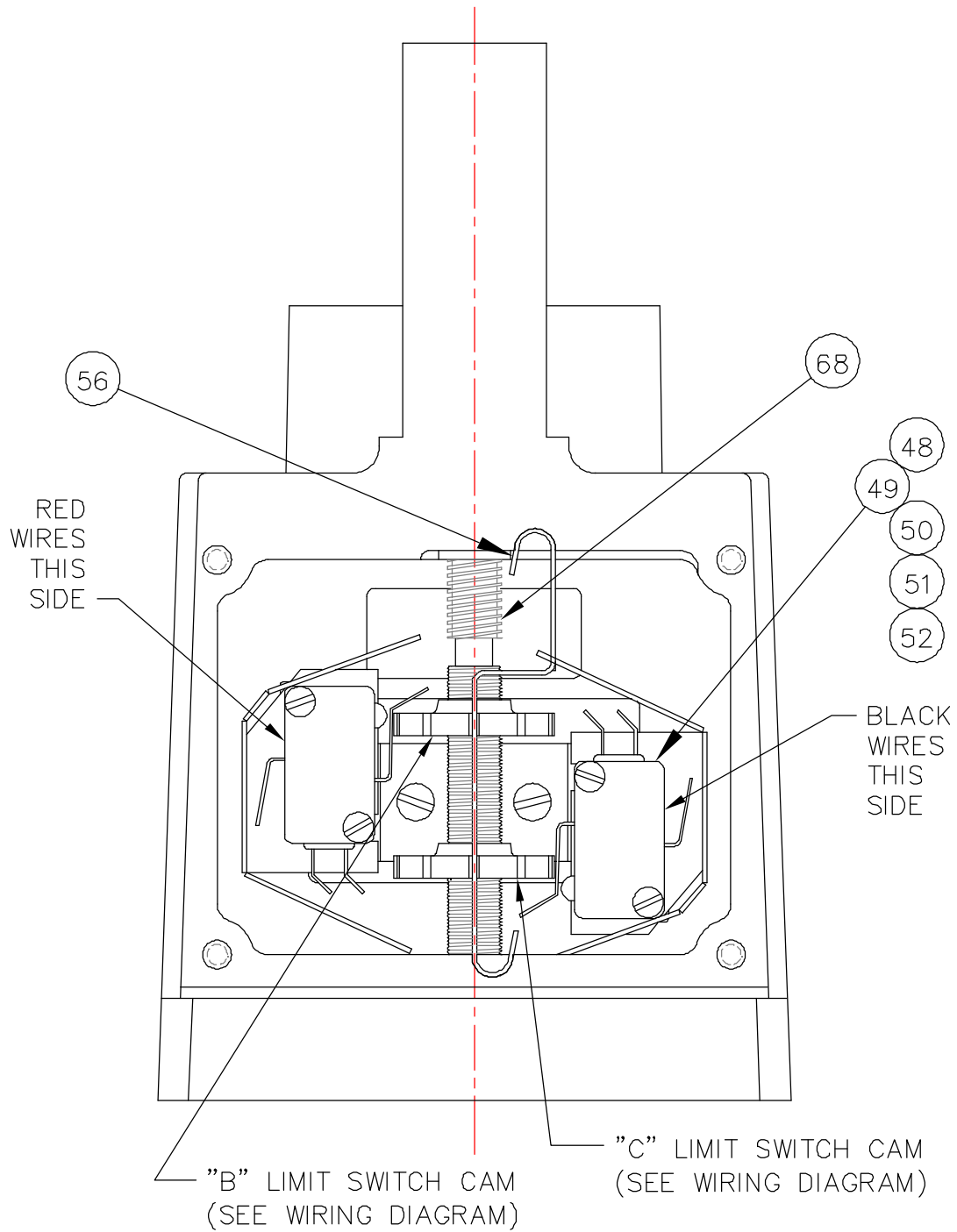

4-3 Brake Assembly Diagram

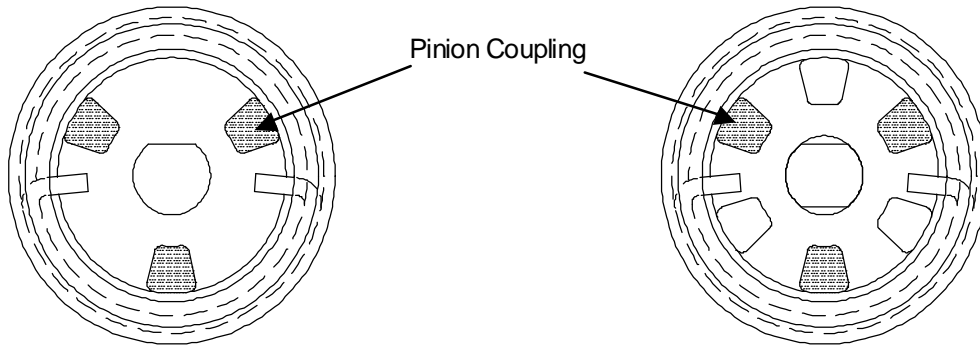

View A

This is a view of the brake assembly installed from the motor end with one coupling half. It is the view looking into the lower housing before the motor coupling half or rubber grommet is assembled.

When properly assembled, this coupling will not rotate in the CW or the CCW direction. This braking action allows the actuator to hold position when the motor is stopped.

View B

This is a view of the installed brake assembly from the motor end with both coupling halves shown. The unshaded coupling tangs are the motor half coupling.

When properly assembled, this coupling half will rotate in both the CW and CCW direction. This allows the motor to be reversed.

4-4 Travel Limit Chart

Models with Limit Switches (18040029) based on clevis end condition

Effective travel (rise)	Minimum dimension	Maximum dimension
3"	17.13	20.13
6"	20.13	26.13
12"	26.13	38.13
18"	32.13	50.13
24"	38.13	62.13

Models with Clutches (18030091) based on clevis end condition

Effective travel (rise)	Minimum dimension	Maximum dimension
3"	17.00	20.00
6"	20.00	26.00
12"	26.00	38.00
18"	32.00	50.00
24"	38.00	62.00

Section V Part Numbers, Ordering and Maintenance Log

5-1 Ordering Information

	Capacity	Voltage	Options	Base Mounting	Screw end	Travel
L A	05 (500#)	2 (12 VDC)	C Clutch	SC Standard Clevis	CL Clevis	03 06 09 12 18
				RC Rotated Clevis	CL Clevis	
			L Limit Switch	SC	CL Clevis	
		5 (115 VAC)	C Clutch	SC Standard Clevis	CL Clevis	
				RC Rotated Clevis	CL Clevis	
			L Limit Switch	SC	CL Clevis	
	15 (1500 #)	2 (12 VDC)	C Clutch	SC Standard Clevis	CL Clevis	03 06 12 18 24
				TM Trunnion Mount	CL Clevis	
				L Limit Switch	SC Standard Clevis	
			L Limit Switch	TM Trunnion Mount	CL Clevis	
				SC Standard Clevis	CL Clevis	
				TM Trunnion Mount	CL Clevis	
	5 (115 VAC)	L Limit Switch	SC Standard Clevis	CL Clevis		
			TM Trunnion Mount	CL Clevis		
			P Limit Switch w/Potentiometer	SC Standard Clevis	CL Clevis	
		P Limit Switch w/Potentiometer	TM Trunnion Mount	CL Clevis		
			SC Standard Clevis	CL Clevis		
			TM Trunnion Mount	TE Threaded		

Linear Actuator part number structure:

Product – Size – Motor Voltage – Options – Modifications – Travel

EXAMPLE – LA152CSCCL-6

Product – LA

Size - 1500# (15)

Motor Voltage – 110 v DC (2)

Options – Limit Switch (L), Clutch (C)

Base Mounting – Standard Clutch (SC)

Screw End – Clevis (CL)

Travel – 6”

