

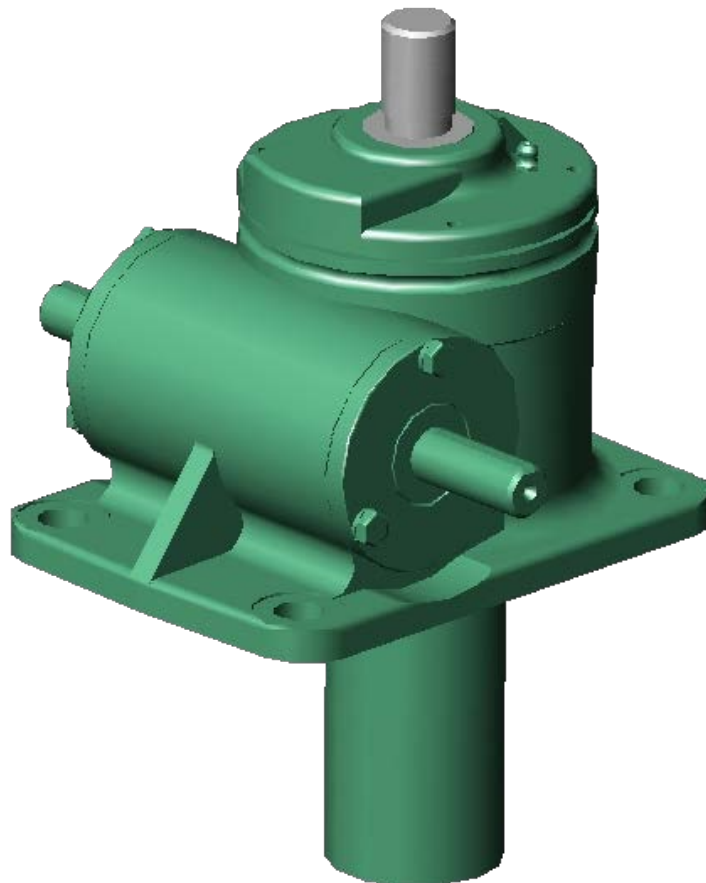

Joyce/Dayton Corp.

---

Operation and Maintenance Manual  
Joyce/Dayton Metric Screw Jacks



**WARNING!**

The product described in this catalog is for industrial use only. It may not be used to lift or support people without prior written approval from the Joyce/Dayton Corp. The recommendations in this manual for installation, operation and maintenance must be followed to ensure safe use. All persons responsible for the installation and use of Joyce Jacks must be familiar with the contents of this manual.

Customer is responsible for providing travel stops.

# Table of Contents

## Section I – General Information

1-1 Contact Joyce Dayton Corp .....	2
1-2 Purpose and Scope.....	2
1-3 Receipt of Product .....	2
1-4 Warranty.....	2
1-5 Precautions of Use and Installation .....	3
1-6 General Installation Instructions.....	3

## Section II – Maintenance

2-1 Lubrication .....	4
2-2 Repair Parts.....	5
2-3 Disassembly of Metric Screw Jack.....	5
2-4 Inspection of Components .....	6
2-5 Assembly of Metric Screw Jack.....	6

## Section III – Views & Parts list

3-1 Exploded views.....	7
3-2 Parts List for Metric Screw Jacks .....	8
3-3 Specifications .....	9
3-4 Serial Number and Maintenance Log.....	10

## Section I General Information

### 1-1 Contact Joyce Dayton Corp.

Joyce Dayton Corp.  
P.O. Box 1630  
Dayton, OH 45401  
(800) 523-5204 (US and Canada only)  
(937) 294-6261 (937) 297-7173 Fax  
Email: [sales@joycedayton.com](mailto:sales@joycedayton.com)  
Website: [www.joycedayton.com](http://www.joycedayton.com)

### 1-2 Purpose and Scope

This manual provides installation, operation and maintenance instruction for standard Joyce Dayton metric screw jacks. Although this manual covers the standard metric jacks and most variations of the Joyce Dayton metric screw jack, there may be some jacks that vary significantly from this manual. For special jacks not covered, please contact Joyce Dayton Corporation for assistance.

### 1-3 Receipt of Product

All equipment should be immediately inspected upon receipt for any damage and to verify correct product and quantities. Any problems should be reported to Joyce/Dayton Corp. and the freight carrier as soon as possible. Products returned without a *Return Goods Authorization (RGA)* form will not be accepted.

### 1-4 Warranty

Seller warrants its products to be free from defects in material and workmanship under normal and proper use in accordance with instruction of seller for a period of one year from the date of shipment to buyer. Seller's liability under such warranty or in connection with any other claim relating to the products shall be limited to the repair, or at seller's

option, the replacement or refund of the purchase price, of any products or parts or components thereof which are returned to seller freight prepaid and which are defective in material or workmanship. Products or parts or components thereof, which are repaired or replaced by seller, will be returned to buyer freight collect. This warranty is not intended to cover consumer products, as defined in the Magnuson-Moss Warranty-Federal Trade Commission Improvement Act, 15 U. S. C. Sections 2301-12, which are purchased by buyer for purposes other than resale. If buyer is not intending to resell the products, and if the products are consumer products as defined in the Magnuson-Moss Act, the foregoing warranty, but not the limitation of seller's liability, shall be null and void. EXCEPT AS EXPRESSLY STATED ABOVE, SELLER MAKES NO WARRANTY, EXPRESS OR IMPLIED, WHETHER OF MERCHANTABILITY OR FITNESS FOR ANY PARTICULAR PURPOSE OR USE OR OTHERWISE, ON THE PRODUCTS, OR ON ANY PARTS OR LABOR FURNISHED DURING THE SALE, DELIVERY OR SERVICING OF THE PRODUCTS.

### **1-5 Precautions of Use and Installation**

1. Side loading of the lifting screw is not permitted in the dynamic operation of the jack. A limited side load is allowable in the static condition. Contact Joyce Dayton for the allowable side load for a specific application.
2. Mechanical stops are not provided on the lifting screw unless requested. Therefore, it is possible to drive the screw out of the jack sleeve (housing). It is the customer's responsibility to provide travel limit devices on all jacks. A mechanical stop, if provided is only an auxiliary device to limit the travel of the lifting screw. Engaging a mechanical stop during jack operation can cause damage to the internal jack mechanism.
3. In most applications, factory or manufacturer-assisted installation is not required. However, it is necessary that appropriate, qualified personnel perform the installation of Joyce Dayton products.
4. Joyce Dayton jacks are not rated for shock-loading, extreme vibration or critical speed conditions (high speed or long-length screw.) It is the responsibility of the user to ensure these conditions are not imposed on a jack or the power transmission equipment.
5. In the event that service or maintenance is required, the load must be secured or removed before any work can begin.
6. The machine screw jacks can be mounted and operated in any orientation. When used in a horizontal position, the worm should be below the gear to ensure proper lubrication.
7. Never allow the jack to retract beyond the minimum closed position, as damage to the jack can occur.
8. Boots or protective bellows covers should be used to protect and keep the lifting screw clean in dusty or abrasive environments.
9. For continuous or high-duty cycles inquire with your local sales representative or consult Joyce Dayton Corp. regarding Bevel Ball actuators.

### **1-6 General Installation instructions**

1. Ensure that all personnel who will service or operate equipment are familiar with its use and limitations.
2. Secure or remove the load before any installation procedures begin.
3. Be certain the rating of the jack meets or exceeds the load.
4. The jacks must be mounted on a structure sufficient to support the maximum possible load. The structure must be rigid. An under-designed structure could lead to bending of the lifting screw causing premature wear or failure.
5. Drive shaft alignment is critical. Mis-alignment will cause reversing stresses in rotating members and will lead to fatigue failure. Correct coupling specification is important.

6. In a system with shafts, miter boxes, etc., confirm that the shafts and jacks operate without binding or excessive force before powered drive devices are engaged.
7. When fastening the load to a jack, ensure that the jack is in the retracted position. This positions the load accurately with respect to the jack screw centerline. Never pull the screw to one side to make connection with your structure. Fully extend the jack to ensure that the load is aligned with the lifting screw.
8. All jacks are to be mounted with S.A.E. Grade 8 bolts or equivalent.
9. Torque all mounting bolts in a symmetric pattern to avoid damage to the sleeve.
10. Shaft and coupling guards are the responsibility of the user.
11. Optional limit switches furnished with the jacks are NOT preset and require field adjustment before use.

## Section II Maintenance

### 2-1 Lubrication

1. Standard jacks are lubricated before leaving the factory.
2. For normal operation, jacks should be greased at least once per month. Under extended use, grease twice monthly or as conditions dictate. Grease thru the fitting on the jack with hand or power operated equipment. Grease with No. 1 Consistency Grease. Do not allow jacks to operate un-lubricated. It is the responsibility of the user to maintain sufficient lubrication of the jack.
3. The products listed below are recommended by the lubricant manufacturers to meet the requirements for normal operation. The listing of brand names is solely for the convenience of users of Joyce equipment and their lubricant suppliers; it does not constitute any endorsement. Joyce/Dayton assumes no responsibilities for the quality, performance or availability of any listed products

<u>COMPANY</u>	<u>BRAND NAME</u>
Mobilgrease .....	XHP 461
Mobil Oil.....	SHC PM 460
Mobil Oil.....	XHP 221
Shell Oil.....	Retinax HD NLGI 1

4. For operation above 250° F or extreme loading, consult an application engineer at Joyce Dayton Corporation.
5. Do not operate jack without lubrication.
6. Total grease capacity by jack type:

Jack Capacity	Shots	Approx. Grease Weight
10 kN	5	1.8 oz.
25 kN	13	4.5 oz.
50 kN	26	9 oz.
100 kN	50	17 oz.

## 2-2 Repair Parts

Obtain repair parts by calling Joyce Dayton Customer Service at (800) 523-5204, (937) 294-6261, (937) 297-9391 (facsimile) or call your local representative. When ordering repair parts, please supply the serial number (located on the jack nameplate).

For recommended repair parts for rebuild or spares, refer to Section 3-1, Exploded View, and Section 3-2, Parts List.

- A. (2) Thrust bearing – Item # 4
- B. (1) Wormgear – Item #5
- C. (2) Worm shaft bearing – Item # 6
- D. (2) Worm shaft seal – Item # 7 (2.5 kN and above)
- E. (1) Shim kit – Assortment of item # 8
- F. (1) Worm – Item #12
- G. (1) Lifting screw – Item #14
- H. (1) Boot (optional, if signs of wear are evident) – Item # 34
- I. (1) Traveling Nut – Item #37 (KFTN model only)

## 2-3 Disassembly of Metric Screw Jacks

Use the appropriate disassembly procedure – if the lifting nut is outside the jack on the screw, the jack is keyed for traveling nut (KFTN), also called a “rotating screw”, otherwise the jack is a translating model. Handle machined parts with care, and maintain an “order of disassembly” to aid in re-assembly. Remove all couplings, screw support bearings, etc. before beginning disassembly.

### Disassembly Procedure for KFTN (rotating screw) Models: see Figure 3-1

1. Remove the boot clamps (item #33) and collapse boots (item # 34) if the jack is equipped with boots. Remove the traveling nut (item # 37) from the screw.
2. Loosen the (4) set screws (item # 13) in the sleeve cap and remove the sleeve cap by rotating counter-clockwise (CCW.)
3. The screw assembly can now be removed from the jack sleeve. The screw assembly consists of the machine screw (item # 14), the upper thrust bearing (item # 4), the key (item # 38) and the wormgear (item # 5). The upper thrust bearing can be removed from the assembly. The wormgear can be pressed off the screw for replacement if necessary. Note: On inverted KFTN models, it may be necessary to remove the screw first.
4. Remove screws (item # 10) from the bearing cap (item # 3). Remove the bearing caps and seals (item # 7) carefully to avoid damaging seals. Make sure keys have been removed first. Note: the MWJ51 jacks have retaining clips (item # 20) instead of bearing caps.
5. Carefully remove the shims (item # 8) from the jack sleeve or bearing cap. NOTE: there will not necessarily be an equal quantity of shims per side. Keep track of the number and order of shims on each side of the jack. The MWJ51 and MWJ201 jacks do not have shims.
6. Remove the worm bearings (item # 6). The cup may be press-fit and require the use of a dead-blow, plastic or other non-marring mallet to remove the worm (item # 12).

### Disassembly Procedure for Translating Models: see Figure 3-1

1. Remove the boot clamps (item # 33) and collapse the boot (item # 34) if equipped. On upright and inverted models, loosen the (4) set screws (item # 13) and remove the sleeve cap (item # 2) by rotating CCW.
2. Remove the protection tube (item #11) and check to see if the lifting screw has travel stops. Removing the protection tube may require the use of a pipe wrench or strap wrench. If the jack has travel stops on the screw, these will need to be removed before

- the lifting screw is removed from the jack. If the jack does not have stops, the lifting screw can be removed by simply unthreading it from the wormgear.
3. Remove the thrust bearings (item # 4) and the wormgear (item # 5) from the sleeve. The bearing cones may be pressed onto the wormgear.
  4. Keyed jacks have a keyway cut the length of the lifting screw (item # 35). A keyed sleeve cap (item # 17) has a key (item # 30), which travels in the keyway and prevents rotation of the lifting screw. It is very important not to allow any side load on a keyed jack, as the key can cut into the lifting screw, and severely affect the life of the jack.
  5. Remove screws, (item # 10) from the bearing caps (item # 3). Remove the bearing caps and seals (item # 7) carefully to avoid damaging seals. Make sure keys have been removed first. Note: the MWJ51 and MWJ201 jacks have retaining clips instead of bearing caps.
  6. Carefully remove the shims (item # 8) from the jack sleeve or bearing cap. NOTE: there will not necessarily be an equal quantity of shims per side. Keep track of the number and order of shims on each side of the jack. The MWJ51 and MWJ201 jacks do not have shims.
  7. Remove the worm shaft bearings (item # 6). The cups may be press-fit and require the use of a dead-blow, plastic or other non-marring mallet to remove the worm (item # 12).

## **2-4 Inspection of Components**

1. Before any inspection, it will be necessary to completely clean all parts of the jack. Use caution with any machined or fragile part.
2. Inspect the cleaned sleeve (item # 1) and sleeve cap (item # 2) for any signs of stress or fracture, especially around the mounting bolt locations.
3. Inspect the worm (item # 12) and thrust bearings (item # 4) for any signs of brinelling, abrasive wear or spalling. Test for smooth, quiet operation of bearings.
4. Inspect bearing caps (item # 3) for any signs of stress.
5. Inspect the keyway on the worm (item # 12) and roll the worm on a flat surface to look for wobble in the shaft. Threads on the worm should not show an excessive buildup of bronze gear material.
6. Replace all seals when a complete disassembly is done.
7. Inspect Aluminum-Bronze wormgear (item # 5) for signs of excessive wear.
8. Check boots (item # 34) for wear or cracks
9. Inspect lifting screw (item # 14) or straightness.

## **2-5 Assembly of Machine Screw Jacks**

1. Assure that all bearings are packed with grease. Coat seals with light oil and put masking tape on keyways and other sharp surfaces to avoid seal damage.
2. Assembly of jack is reverse of the disassembly procedure. Make sure all bearings and seals seat properly. The bearing cap screws and sleeve cap should only be hand tightened initially. Some jacks may require the wormgear and thrust bearing be installed first, as they will not pass the worm, if already installed.
3. Tighten bearing cap bolts. Check the input shaft for excessive axial or lateral movement. If the input shaft feels loose remove shims, if it feels tight, add shims. Give the input shaft a solid blow on each end (in axial direction) with a soft mallet and re-check the feel. If it feels OK, continue to next step, otherwise continue adjusting the shims. This is a trial and error operation. The correct set-up has a solid feel without play (axial or lateral) and the input shaft rotates with an even, smooth but snug feel.
4. When jack is re-assembled, the thrust bearing pre-load needs to be set. Check by rotating the input shaft, while tightening the sleeve cap. Continue to check the rotation of the input shaft as the sleeve cap is tightened. Use a dead-blow hammer on top of sleeve cap to help it seat. Tighten sleeve cap until it will not tighten further by hand.

# Section III Views & Parts List

## 3-1 Exploded View

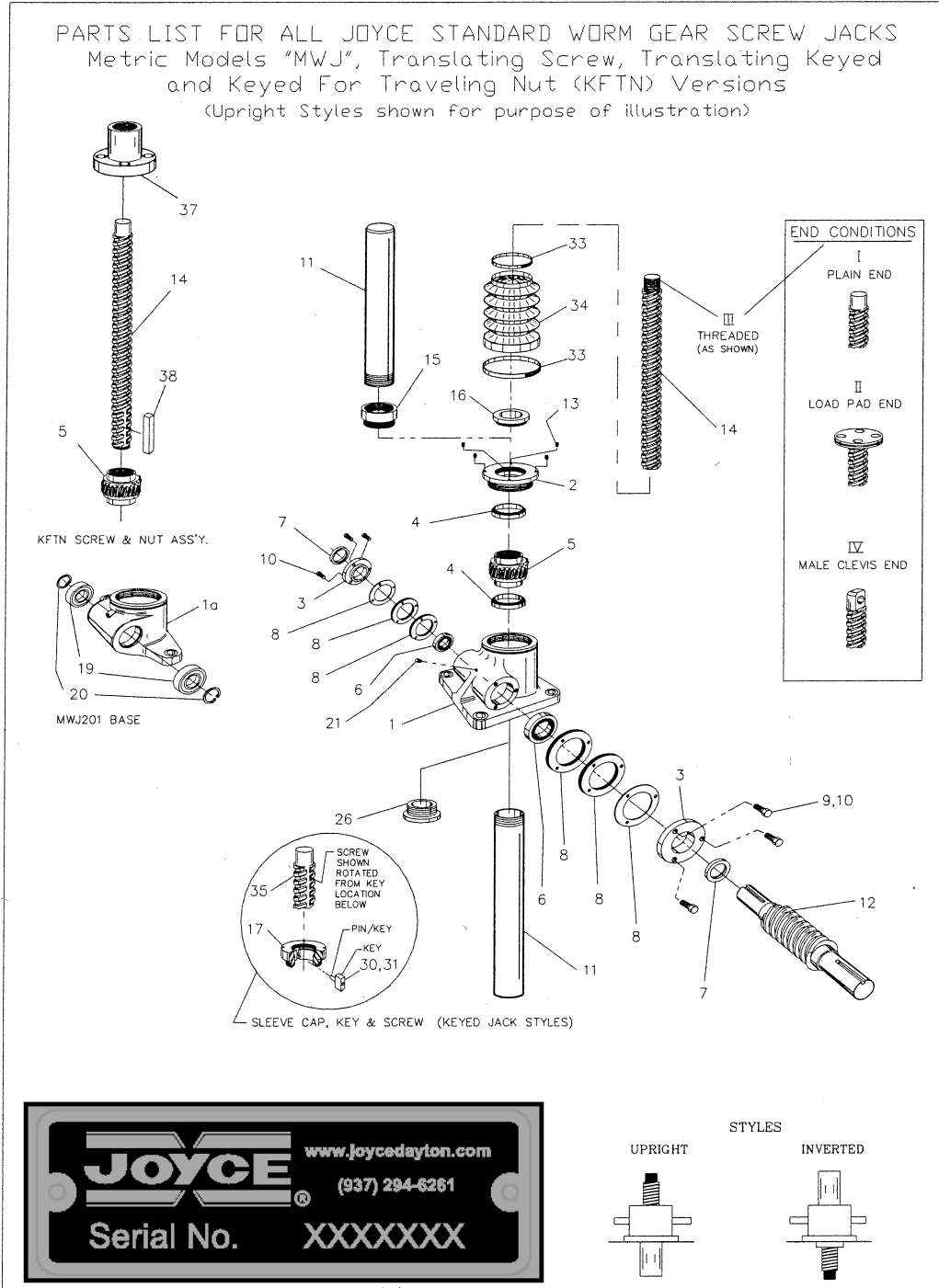

### 3-2 Parts List – Translating and KFTN jacks

**Table 3-1 Metric Parts list**

Item	Translating	Item	KFTN- Keyed For Traveling Nut
1	Sleeve	1	Sleeve
1a	Sleeve (MWJ51 & MWJ201 jack)	1a	Sleeve (MWJ51 & MWJ201 jack)
2	Sleeve Cap	2	Sleeve Cap
3	Bearing Cap (2)	3	Bearing Cap (2)
4	Thrust Bearing	4	Thrust Bearing
5	Wormgear	5	Wormgear
6	Worm Shaft Bearing (2)	6	Worm Shaft Bearing (2)
7	Worm Shaft Seal (2)	7	Worm Shaft Seal (2)
8	Shims	8	Shims
9	Bearing Cap Lockwasher (6-8)	9	Bearing Cap Lockwasher (6-8)
10	Bearing Cap Screw (6-8)	10	Bearing Cap Screw (6-8)
11	Protection Tube	11	-----
12	Worm (Input Shaft)	12	Worm (Input Shaft)
13	Set Screw – sleeve cap (4)	13	Set Screw - sleeve cap (4)
14	Lifting Screw	14	Lifting Screw
15	Protection Tube Adapter (Inverted only)	15	-----
16	-----	16	Seal
17	Keyed Sleeve Cap	17	-----
18	O-ring seal**	18	O-ring seal**
19	Bushing (MWJ51 & MWJ201 jacks only) (2)	19	Bushing (MWJ51 & MWJ201 jacks only) (2)
20	Retaining Ring (MWJ51 & MWJ201 jacks only) (2)	20	Retaining Ring (MWJ51 & MWJ201 jacks only) (2)
21	Grease Fitting	21	Grease Fitting
22	Drive Screw (2)	22	Drive Screw (2)
23	Name Plate	23	Name Plate
24	Top Bushing**	24	Top Bushing**
25	-----	25	-----
26	Bushing (inverted only)	26	Bushing (inverted only)
27	Base Plate**	27	-----
28	Sleeve Bolts (16)	28	Sleeve Bolts (16)
29	Base Shim	29	Base Shim
30	Key – keyed jacks	30	-----
31	Key screw – keyed jacks	31	-----
32	Alignment Pin	32	-----
33	Boot Clamp	33	Boot Clamp
34	Bellows Boot	34	Bellows Boot
35	Keyed Screw	35	-----
36	Sleeve cap screws (8)**	36	-----
37	-----	37	Traveling Nut
38	-----	38	Key - KFTN

\* Keyed Jack styles only



### 3-3 Specifications

Model Number	MWJ51 MWJ201	MWJT62.5 MWJT122.5 MWJT242.5	MWJT65 MWJT125 MWJT245	MWJ810 MWJ2410
Capacity	10 kN	25 kN	50 kN	100 kN
Screw Tr	20 x 5	30 x 6	40 x 9	55 x 12
Worm Gear Ratio	5:1 20:1	6:1 12:1 24:1	6:1 12:1 24:1	8:1 24:1
Worm Shaft Turns for 1 mm	1 4	1 2 4	0.67 1.33 2.67	0.67 2
Tare Torque (Nm)	0.33	0.67	1.13	2.26
Starting Torque (Nm)	.95 W* .41 W*	1.01 W* 0.62 W* 0.44 W*	1.64 W* 1.03 W* 0.74 W*	1.53 W* 0.76 W*
Operating Torque (Nm) @ Worm RPM	0.70 W* 0.23 W* @ 500 RPM	0.81 W* 0.45 W* 0.27 W* @ 500 RPM	1.14W* 0.64 W* 0.39 W* @ 300 RPM	1.18 W* 0.49 W* @ 200 RPM
Screw Torque (Nm)	2 W*	3 W*	4 W*	5 W*
Efficiency Rating % approx.	22.7 % 17.0 %	19.6 % 17.8 % 14.7 %	20.9 % 18.7 % 15.2 %	20.2 % 16.1 %
Basic Jack Weight (Kg)	2.7	6.8	14.5	19.5
Add to Basic Jack Weight (Kg) for each Additional 25 mm of Travel	0.14	0.18	0.32	0.59

\*W = Load in k N

Screw Torque is the force required to keep the screw from rotating.

Operating torque for a given load increases as speed decreases

**3-4 Serial Number Tag and Maintenance Log**

<b>Date</b>	<b>Maintenance Performed</b>	<b>Initials</b>

**Joyce Dayton Serial Number Tag**



**Contact Joyce Dayton Corporation and provide the serial number to obtain the product information needed for maintenance, repair and reorder.**

**Joyce Dayton Corp  
P.O. Box 1630  
Dayton, Ohio 45401  
Phone (800) 523-5204 (U.S. & Canada); (937) 294-6261 Fax (937) 297-7173  
[www.joycedayton.com](http://www.joycedayton.com) E-mail: [sales.jacks@joycedayton.com](mailto:sales.jacks@joycedayton.com)**