



**Joyce/Dayton Corp.**

**Operation and Maintenance Manual for Joyce/Dayton**

**Stainless Steel Machine Screw Jacks**

---

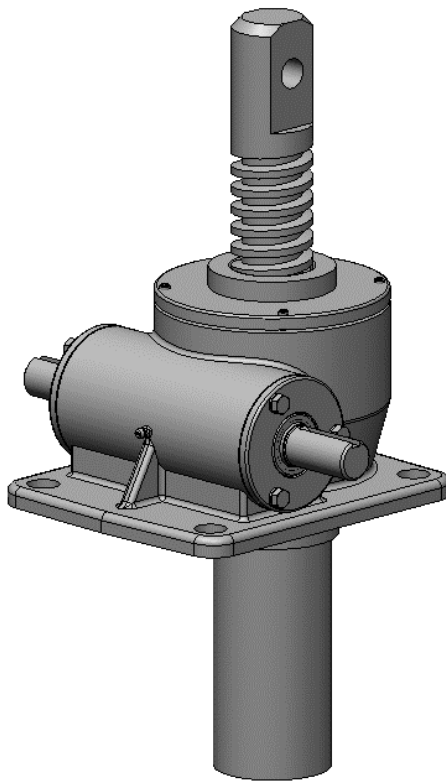

**The product described in this catalog is for industrial use only. It may not be used to lift or support people without prior written approval from the Joyce/Dayton Corp. Recommendations in this manual for installation, operation and maintenance must be followed to ensure safe use. All persons responsible for the installation and use of Joyce Stainless Steel Jacks must be familiar with the contents of this manual.**

**Customer is responsible for providing travel stops.**

©2011 Joyce/Dayton Corp. All rights reserved

FB0164 – 6/11

---

# Table of Contents

## Section I – General Information

1-1 Contact Joyce/Dayton .....	2
1-2 Purpose and Scope.....	2
1-3 Receipt of Product .....	2
1-4 Warranty.....	2
1-5 Precautions of Use and Installation .....	3
1-6 General Installation Instructions.....	3

## Section II – Maintenance

2-1 Lubrication .....	4
2-2 Repair Parts.....	4
2-3 Disassembly of Stainless Steel Machine Screw Jacks.....	5
2-4 Inspection of Components .....	6
2-5 Assembly of Stainless Steel Machine Screw Jacks .....	6

## Section III – Views & Parts list

3-1 Exploded View .....	7
3-2 Parts List .....	8
3-3 Specifications.....	9
3-4 Serial Number and Maintenance.....	11

## Section I General Information

### 1-1 Contact Joyce/Dayton Corp.

Joyce/Dayton Corp.  
P.O. Box 1630  
Dayton, OH 45401  
(800) 523-5204 (US and Canada only)  
(937) 294-6261 (937) 297-7173 Fax  
Email: [sales@JoyceDyton.com](mailto:sales@JoyceDyton.com)  
Website: [www.joycedayton.com](http://www.joycedayton.com)

### 1-2 Purpose and Scope

This manual provides installation, operation and maintenance instruction for standard Joyce/Dayton Stainless Steel Machine Screw Jacks. Although this manual covers the standard jacks and most variations there may be some jacks that vary significantly from this manual. For special jacks not covered, please contact Joyce/Dayton Corp. for assistance.

### 1-3 Receipt of Product

All equipment should be immediately inspected upon receipt for any damage and to verify correct product and quantities. Any problems should be reported to Joyce/Dayton Corp. and the freight carrier as soon as possible. Products returned without a *Return Goods Authorization (RGA)* form will not be accepted.

### 1-4 Warranty

Seller warrants its products to be free from defects in material and workmanship under normal and proper use in accordance with instruction of seller for a period of one year from the date of shipment to buyer. Seller's liability under such warranty or in connection with any other claim relating to the products shall be limited to the repair, or at seller's option, the replacement or refund of the purchase price, of any products or parts or components thereof which are returned to seller freight prepaid and which are defective in

material or workmanship. Products or parts or components thereof, which are repaired or replaced by seller, will be returned to buyer freight collect. This warranty is not intended to cover consumer products, as defined in the Magnuson-Moss Warranty-Federal Trade Commission Improvement Act, 15 U. S. C. Sections 2301-12, which are purchased by buyer for purposes other than resale. If buyer is not intending to resell the products, and if the products are consumer products as defined in the Magnuson-Moss Act, the foregoing warranty, but not the limitation of seller's liability, shall be null and void. EXCEPT AS EXPRESSLY STATED ABOVE, SELLER MAKES NO WARRANTY, EXPRESS OR IMPLIED, WHETHER OF MERCHANTABILITY OR FITNESS FOR ANY PARTICULAR PURPOSE OR USE OR OTHERWISE, ON THE PRODUCTS, OR ON ANY PARTS OR LABOR FURNISHED DURING THE SALE, DELIVERY OR SERVICING OF THE PRODUCTS.

### **1-5 Precautions of Use and Installation**

1. Side loading of the lifting screw is not permitted in the dynamic operation of the jack. A limited side load is allowable in the static condition. Contact Joyce/Dayton for the allowable side load for specific applications.
2. Mechanical stops are not provided on the lifting screw unless requested. Therefore, it is possible to drive the screw out of the jack sleeve (housing). It is the customer's responsibility to provide travel limit devices on all jacks. A mechanical stop, if provided is only an auxiliary device to limit the travel of the lifting screw. Engaging a mechanical stop during jack operation can cause damage to the internal jack mechanism.
3. In most applications, factory or manufacturer-assisted installation is not required. However, it is necessary that appropriate, qualified personnel perform the installation of Joyce/Dayton products.
4. Joyce/Dayton stainless steel screw jacks are not rated for shock-loading, extreme vibration or critical speed conditions (high speed or long-length screw.) It is the responsibility of the user to ensure these conditions are not imposed on a jack or the power transmission equipment. Contact Joyce/Dayton Corp. for technical assistance.
5. In the event that service or maintenance is required, the load must be secured or removed before any work can begin.
6. The stainless steel machine screw jacks can be mounted and operated in any orientation. When used in a horizontal position, the worm should be mounted parallel with the horizon and below the gear to ensure proper lubrication.
7. Never allow the jack screw to retract beyond the minimum closed position, as damage to the jack can occur.
8. Boots or protective bellows covers should be used to protect and keep the lifting screw clean in dusty or abrasive environments.
9. For continuous or high-duty cycles inquire with your local sales representative or consult Joyce/Dayton Corp. about other products suited for near-continuous duty operation (i.e. Bevel Ball actuators, which are not stainless steel).

### **1-6 General Installation instructions**

1. Ensure that all personnel who will service or operate equipment are familiar with its use and limitations.
2. Secure or remove the load before any installation procedures begin
3. Be certain the rating of the jack meets or exceeds the load.
4. The jacks must be mounted on a structure sufficient to support the maximum possible load. The structure must be rigid. An under-designed structure could lead to bending of the lifting screw causing premature wear or failure.
5. Drive shaft alignment is critical. Mis-alignment will cause reversing stresses in rotating members and will lead to fatigue failure. Correct coupling specification is important.
6. In a system with shafts, miter boxes, etc., confirm that the shafts and jacks operate without binding or excessive force before powered drive devices are engaged.

7. When fastening the load to a jack, make sure the jack is in the retracted position. This positions the load accurately with respect to the jack screw centerline. Never pull the screw to one side to make connection with your structure. Fully extend the jack to make sure the load is aligned with the lifting screw.
8. Jacks should be mounted with S.A.E. Grade 8 bolts or equivalent.
9. Torque all mounting bolts in a symmetric pattern to avoid damage to the sleeve.
10. Shaft and coupling guards are the responsibility of the user.
11. Optional limit switches furnished with the jacks are NOT preset and require field adjustment before use. These limit switches do not have stainless steel housings.

## Section II Maintenance

### 2-1 Lubrication

1. Jacks are lubricated before leaving the factory.
2. For normal operation, jacks should be greased at least once per month. Under extended use, grease twice monthly or as conditions dictate. Grease through the fitting on the jack with hand or power operated equipment. Grease with No. 1 Consistency Grease. Do not allow jacks to operate without lubrication. It is the responsibility of the user to maintain sufficient lubrication of the jack.
3. The products listed below are recommended by the lubricant manufacturers to meet the requirements for normal operation. The listing of brand names is solely for the convenience of users of Joyce equipment and their lubricant suppliers; it does not constitute any endorsement. Joyce/Dayton assumes no responsibilities for the quality, performance or availability of any listed products

<u>COMPANY .....</u>	<u>BRAND NAME</u>
Mobilgrease .....	XHP 461
Shell Oil Company .....	Retinax HD NLGI 1
Shell Oil Company .....	Albina SLC 460
Mobil Oil.....	Mobilith SHC PM 460

4. For operation above 250°F or extreme loading, consult the Engineering Department of Joyce/Dayton Corp. (sales@joycedayton.com).
5. Do not operate jack without lubrication.
6. Total grease capacity by jack type:

Jack Capacity	Shots	Approximate Weight
2 ton	13	4.5 oz
5 ton	26	9 oz
10-15 ton	50	17 oz
20 ton	95	33 oz.
25 ton	140	49 oz.

### 2-2 Repair Parts

Obtain repair parts by contacting Joyce/Dayton Customer Service at (800) 523-5204, (937) 294-6261, (937) 297-7371 (facsimile), sales@joycedayton.com, or call your local sales representative. When ordering repair parts, please supply the serial number (located on the jack nameplate).

Recommended repair parts for rebuild or spares. Refer to Section 3-1 Exploded view and Section 3-2 Parts List.

- A. (1) Thrust bearing – Item 4
- B. (1) Wormgear – Item 5
- C. (2) Worm shaft bearing and race – Item 6
- D. (2) Worm shaft seal – Item 7 (2-ton and above)
- E. (1) Shim kit – Assortment of item 8
- F. (1) Worm - 12
- G. (1) Lifting screw - 14
- H. (1) Boot (if signs of wear are evident) – Item 24
- I. (1) Traveling Nut - 26

### **2-3 Disassembly of Stainless Steel Machine Screw Jacks**

Use the appropriate disassembly procedure – if the lifting nut is outside the jack on the screw, the jack is a Keyed for Traveling Nut (KFTN), also called a “rotating screw”, otherwise the jack is a translating model. Handle machined parts with care, and maintain an “order of disassembly” to aid in re-assembly. Remove all couplings, screw support bearings, etc. before beginning disassembly.

#### **Disassembly Procedure for KFTN (rotating screw) Models: see Figure 3-1**

1. Remove the boot clamps (item 23) and collapse boots (item 24), if the jack is equipped with boots. Remove the traveling nut (item 26) from the screw.
2. Loosen the (4) set screws (item 13) in the sleeve cap and remove the sleeve cap by rotating counter-clockwise (CCW.)
3. The screw assembly can now be removed from the jack sleeve. The screw assembly consists of the machine screw (item 14), the upper thrust bearing (item 4), the key (item 27), retaining ring (item 28) and the wormgear (item 5). The upper thrust bearing can be removed from the assembly. The wormgear can be pressed off the screw for replacement if necessary. Note: On inverted KFTN models, it may be necessary to remove the screw first.
4. Remove screws (item 10) from the bearing cap (item 3). Remove the bearing caps and seals (item 7) carefully to avoid damaging seals. Make sure keys have been removed first.
5. Carefully remove the shims (item 8) from the jack sleeve or bearing cap. NOTE: there will not necessarily be an equal quantity of shims per side. Keep track of the number and order of shims on each side of the jack.
6. Remove the worm bearings (item 6). The cup may be press-fit and require the use of a dead-blow, plastic or other non-marring mallet to remove the worm (item 12).

#### **Disassembly Procedure for Translating Models: see Figure 3-1**

1. Remove the boot clamps (item 23) and collapse the boot (item 24) if equipped. On upright and inverted models, loosen the (4) set screws (item 13) and remove the sleeve cap (item 2) by rotating CCW.
2. Remove the protection tube (item 11) and check to see if the lifting screw has travel stops. This may require the use of a pipe wrench or strap wrench. If the jack has travel stops on the screw, these will need to be removed before the lifting screw is removed from the jack. If the jack does not have stops, the lifting screw can be removed by simply unthreading it from the wormgear.
3. Remove the thrust bearings (item 4) and the wormgear (item 5) from the sleeve. The bearing cones may be pressed onto the wormgear.
4. Keyed jacks have a keyway cut the length of the lifting screw (item 14). A steel sleeve cap (item 2) has a key (item 321), which travels in the keyway and prevents rotation of

the lifting screw. It is very important not to allow any side load on a keyed jack, as the key can cut into the lifting screw, and severely affect the life of the jack.

5. Remove screws, (item 10) from the bearing caps (item 3). Remove the bearing caps and seals (item 7) carefully to avoid damaging seals. Make sure keys have been removed first.
6. Carefully remove the shims (item 8) from the jack sleeve or bearing cap. NOTE: there will not necessarily be an equal quantity of shims per side. Keep track of the number and order of shims on each side of the jack.
7. Remove the worm shaft bearings (item 6). The cups may be press-fit and require the use of a dead-blow, plastic or other non-marring mallet to remove the worm (item 12).

#### **2-4 Inspection of Components**

1. Before any inspection, it will be necessary to completely clean all parts of the jack. Use caution with any machined or fragile part.
2. Inspect the cleaned sleeve (item 1) and sleeve cap (item 2) for any signs of stress or fracture, especially around the mounting bolt locations.
3. Inspect the worm (item 12) and thrust bearings (item 4) for any signs of brinelling, abrasive wear or spalling. Test for smooth, quiet operation of bearings.
4. Inspect bearing caps (item 3) for any signs of stress.
5. Inspect the keyway on the worm (item 12) and roll the worm on a flat surface to look for wobble in the shaft. Threads on the worm should not show an excessive buildup of bronze gear material.
6. Replace all seals when a complete disassembly is done.
7. Inspect aluminum-bronze wormgear (item 5) for signs of excessive wear.
8. Check boots (item 24) for wear or cracks
9. Inspect lifting screw (item 14) or straightness.

#### **2-5 Assembly of Stainless Steel Machine Screw Jacks**

1. Assure that all bearings are packed with grease. Coat seals with light oil and put masking tape on keyways and other sharp surfaces to avoid seal damage.
2. Assembly of jack is reverse of the disassembly procedure. Make sure all bearings and seals seat properly. The bearing cap screws and sleeve cap should only be hand tightened, initially. Some jacks may require the wormgear and thrust bearing be installed first, as they will not pass the worm, if already installed.
3. Tighten bearing cap bolts. Check the input shaft for excessive axial or lateral movement. If the input shaft feels loose remove shims, if it feels tight, add shims. Give the input shaft a solid blow on each end (in axial direction) with a soft mallet and re-check the feel. If it feels OK, continue to next step, otherwise continue adjusting the shims. This is a trial and error operation. The correct set-up has a solid feel without play (axial or lateral) and the input shaft rotates with an even, smooth but snug feel.
4. When jack is re-assembled, the thrust bearing pre-load needs to be set. Check by rotating the input shaft, while tightening the sleeve cap. Continue to check the rotation of the input shaft as sleeve cap is tightened. Use a dead-blow hammer on top of sleeve cap to help it seat. Tighten sleeve cap until it will not tighten further by hand.

### 3-1 Exploded View

PARTS LIST FOR ALL JOYCE STANDARD STAINLESS STEEL MACHINE SCREW JACKS  
 MODELS "SWJ", "DSWJ", "RSWJ", And "DRSWJ" Translating Screw,  
 Keyed, and Keyed For Traveling Nut Versions  
 (Upright Style shown for illustration)

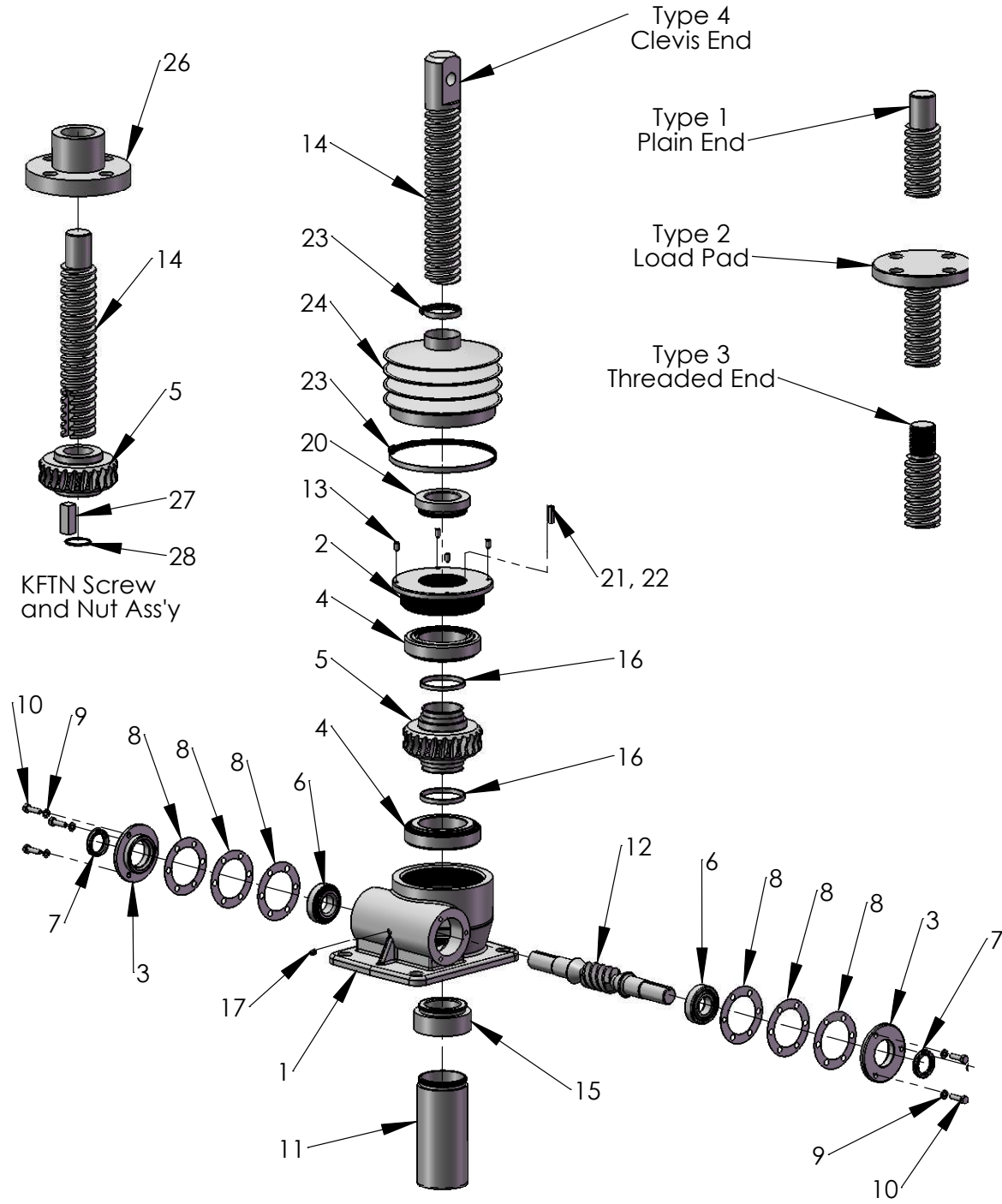

### 3-2 Parts List – Translating and KFTN jacks

**Parts list Table**

Item	Translating	Item	KFTN- Keyed For Traveling Nut
1	Sleeve	1	Sleeve
2	Sleeve Cap	2	Sleeve Cap
3	Bearing Cap (2)	3	Bearing Cap (2)
4	Thrust Bearing	4	Thrust Bearing
5	Wormgear	5	Wormgear
6	Worm Shaft Bearing (2)	6	Worm Shaft Bearing (2)
7	Worm Shaft Seal (2)	7	Worm Shaft Seal (2)
8	Shims	8	Shims
9	Bearing Cap Lockwasher (6-8)	9	Bearing Cap Lockwasher (6-8)
10	Bearing Cap Screw (6-8)	10	Bearing Cap Screw (6-8)
11	Protection Tube	12	Worm (Input Shaft)
12	Worm (Input Shaft)	13	Set Screw - sleeve cap (4)
13	Set Screw – sleeve cap (4)	14	Lifting Screw
14	Lifting Screw	16	Seal (2)
15	Protection Tube Adapter	17	Grease Fitting
16	Seal (2)	18	Drive Screw (2)
17	Grease Fitting	19	Name Plate
18	Drive Screw (2)	20	Flange Bushing
19	Name Plate	23	Boot Clamp
20	Flange Bushing	24	Bellows Boot
21	Key– keyed jacks only	26	Traveling Nut
22	Key screw* – keyed jacks only	27	Key - KFTN
23	Boot Clamp	28	Retaining Ring
24	Bellows Boot		

### Styles

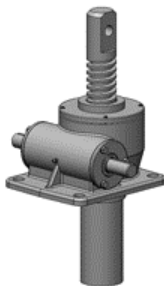

**Upright**



**Inverted**



### 3-3 Specifications

Model Number	(RS)WJT62 (R)SWJT122 (R)SWJT242 (R)SWJT252	D(R)SWJ62 D(R)SWJ122 D(R)SWJ242	SWJT65 SWJT125 SWJT245	DSWJ65 DSWJ125 DSWJ245	SWJ810 SWJ2410	DSWJ810 DSWJ2410
Capacity	2 TON	2 TON	5 TON	5 TON	10 TON	10 TON
Lifting Screw Diameter (inches)	1	1	1 1/2	1-1/2	2	2
Thread Pitch/Lead (inches)	.250 Pitch Acme	.250 Pitch .500 Lead Acme	.375 Pitch Stub Acme	.250 Pitch .500 Lead Acme	.500 Pitch Acme	.333 Pitch .667 Lead Acme
Worm Gear Ratio	6:1 12:1 24:1	6:1 12:1 24:1	6:1 12:1 24:1	6:1 12:1 24:1	8:1 24:1	8:1 24:1
Worm Shaft Turns for 1" Travel	24 48 96	12 24 48	16 32 64	12 24 48	16 48	12 36
Tare Torque Inch-lbs.	6	6	15	10	30	30
Starting Torque Inch lbs.	.041W* .025W* .018W *	.057W* .035W* .025W*	.065W* .041W* .029W*	.072W* .045W* .033W*	.061W* .030W*	.701W* .035W*
Operating Torque † (inch lbs.)	.028W* .015W* .009W* @ 500 RPM	.039W* .022W* .013W* @ 500 RPM	.044W* .025W* .015W* @ 300 RPM	.050W* .028W* .017W* @ 300 RPM	.043W* .018W* @ 200 RPM	.062W* .026W* @ 200 RPM
Screw Torque ** (inch lbs.)	.098W*	.139 W*	.151 W*	.171 W*	.195W*	.228W*
Efficiency Rating approx.	24.2% 22.0% 18.3%	33.7% 30.5% 25.4%	23.0% 20.6% 16.7%	26.8% 23.9% 19.6%	23.1% 18.8%	31.9% 25.9%
Basic Jack Weight (lbs.)	15	15	32	32	43	43
Add to Basic Jack Weight (lbs.) for each Additional 1" of Travel	.3	.3	.7	.7	1.3	1.3

Series DWJ may lower under load. External locking systems are required

W\* = Load in pounds

\*\*Screw torque is the torque required to keep the screw from rotating.

† Operating torque: torque required for a given load increases as speed decreases

### 3.3 Specifications (continued)

Model Number	SWJ815 SWJ2415	DSWJ815 DSWJ2415	SWJ820 SWJ2420	DSWJ820 DSWJ2420	SWJ1125 SWJ3225	DSWJ1125 DSWJ3225
Capacity	15 TON	15 TON	20 TON	20 TON	25 TON	25 TON
Lifting Screw Diameter (inches)	2 1/4	2 1/4	2 1/2	2 1/2	3 3/8	3 3/8
Thread Pitch/Lead (inches)	.500 pitch Acme	.333 Pitch .666 Lead Acme	.500 pitch Acme	.375 Pitch .750 Lead Acme	.666 Pitch Stub Acme	.5625 Pitch 1.125 Lead Acme
Worm Gear Ratio	8:1 24:1	8:1 24:1	8:1 24:1	8:1 24:1	11:1 32:1	11:1 32:1
Worm Shaft Turns for 1" Travel	16 48	12 36	16 48	10.67 32	16 48	9.5 28.5
Tare Torque Inch-lbs.	45	45	60	60	75	75
Starting Torque Inch lbs.	.069W* .036W*	.079W* .041W*	.075W* .039W*	.088W* .046W*	.088W* .053W*	.106W* .063W*
Operating Torque † (inch lbs.)	.047W* .020W* @ 200 RPM	.058W* .025W* @ 200 RPM	.015W* .022W* @ 200 RPM	.061W* .026W* @ 200 RPM	.055W* .025W* @ 200 RPM	.067W* .030W* @ 200 RPM
Screw Torque ** (inch lbs.)	.210W*	.244W*	.227W*	.272W*	.313W*	.384W**
Efficiency Rating approx.	21.1% 16.6%	34.4% 27.0%	19.6% 15.4%	24.5% 19.3%	18.3% 13.5%	25.1% 18.6%
Basic Jack Weight (lbs.)	59	59	77	77	164	164
Add to Basic Jack Weight (lbs.) for each Additional 1" of Travel	1.4	1.4	1.9	1.9	3.1	3.1

Series DWJ may lower under load. External locking systems are required

W\* = Load in pounds

\*\*Screw torque is the torque required to keep the screw from rotating.

† Operating torque: torque required for a given load increases as speed decreases

