

OPTIONS, ACCESSORIES AND CONTROLS

Options:

Boots 166-168
Limit Switches 170
Potentiometers 171
Encoders 172-173
Servo Motor Mounts 174
Motor Mounts and Stock Motors 175
Hand Wheels and Counters 176
Anti-Backlash Devices 177
Special Finishes 178
Trunnion Mounts 179

Accessories:

Pillow Blocks and Flange Blocks 180
Miter Gear Boxes 181-183
Couplings 184-185
Shafting 186-187

Controls:

Motor Starters 188
Programmable Controls 189

Systems:

Common Arrangements 190

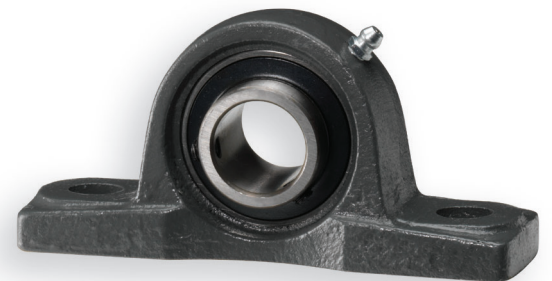

Choose the Joyce options, accessories and motor controls needed to complete your jack system.

We offer everything from protective boots and anti-backlash devices to special materials and finishes. The information needed to complete a system can be found on the pages that follow.

Select components for single- or multiple-jack systems. Choose miter boxes, pillow block supports, shafting and couplings.

Finish the system with a standard motor control, or let us know your requirements. We offer an extensive line of motor starters as well as programmable controls for synchronized systems and leveling systems.

Joyce has been designing systems for decades. Our experienced application engineers can help you put it all together. Contact us today.

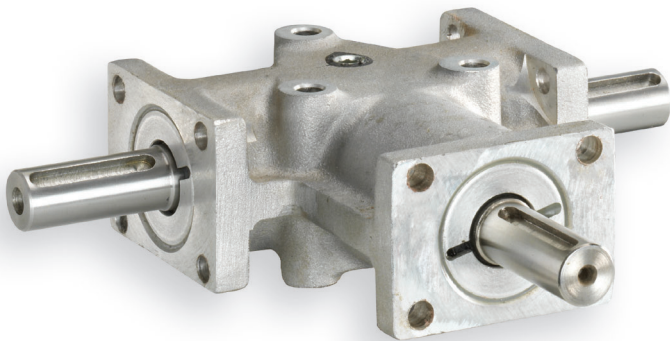

Scan the QR Code to view options on our website.

OPTIONS BOOTS FOR MACHINE SCREW JACKS

For Translating and Keyed Design Machine Screw Jacks

When boots are included on the Joyce jacks or actuators, Joyce sizes them as part of our service to you.

Adding boots to most jacks increases their retracted (closed) height, "A" or "B". The diagrams and chart below are provided as a reference to help illustrate how the addition of standard boots to jacks increases the closed height of those jacks.

The retracted (closed) height, "A" or "B", is based on the jack capacity and it changes based on the length of travel (rise), and end condition of the lifting screw. For instance, an upright 2-ton jack with a T3 end condition and 12 inches of rise will have a greater closed dimension than the same 2-ton jack with just 3 inches of rise.

Standard boot outside diameter, "C", and collar diameter at the base of the jack, "D" are listed in the chart below for reference.

Although Joyce provides the stainless steel clamps needed to secure all boots in place, customers must provide a mounting ring of the standard diameter "D" to mount the boots on inverted jacks.

When you use Joyce 2D/3D online software to specify jacks with boots, the drawings will more accurately depict the added screw length needed to accommodate the boot. However, the actual boot will not be shown on the drawing.

Common Boot Options:

- Zippered boots
- Boots for high temperatures

Contact Joyce for more information about these and other custom boot applications or boots for Bevel Gear Jacks.

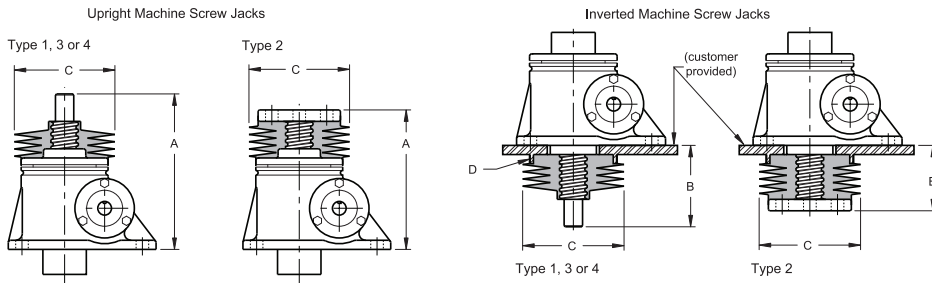

Jack Capacity	A - Closed Height for Upright Jack				Max. Travel Without Increasing Closed Height - Upright Type 2**	B - Closed Height for Inverted Jack				C O.D. of Boot	D Collar Diameter
	Type 1*	Type 2	Type 3*	Type 4*		Type 1*	Type 2*	Type 3*	Type 4*		
250/500 Lb.	4 1/2	4	4 1/2	3 3/4	12	2 3/4	1 5/8	2 3/4	2	3.5	2 5/16
1,000 Lb.	4	4	4	4	12	3	2	3	2 1/4	3.5	2 5/16
1 Ton	5 3/8	4 1/2	5 3/8	5 3/8	9	2 1/2	1 15/16	2 1/2	2 1/2	5	2 3/4
2 Ton	6	5 5/16	6	6 1/4	3	2 7/8	2 1/16	2 7/8	3 3/16	5	3 3/4
3 Ton	5 15/16	5 1/4	5 15/16	6 3/4	0	2 5/8	1 15/16	2 5/8	3 1/2	5	3 3/4
5 Ton	7 3/4	7 1/16	7 3/4	8 1/4	6	3 7/8	2 11/16	3 7/8	4 3/8	5 1/2	4 3/4
10 Ton	8	7 1/4	8	8 11/16	9	4	2 1/2	4	4 11/16	6 1/2	5 3/4
15 Ton	8 3/4	8	8 3/4	9 7/16	9	4	2 1/2	4	4 11/16	6 1/2	5 3/4
20 Ton	9 15/16	9 1/4	9 15/16	10 3/4	9	3 15/16	2 1/2	3 15/16	4 3/4	6 1/2	6
25 Ton	11 3/8	11	12 1/4	12 3/4	9	4 1/16	2 7/8	4 15/16	5 7/16	8	7 1/2
30 Ton	11 15/16	11 1/2	11 3/16	17 1/16	21	4 15/16	4 1/8	4 3/16	9 11/16	8	8 1/4
35 Ton	13 5/8	12	13 5/8	13 5/8	0	6 11/16	5 1/16	6 11/16	6 11/16	10	8 1/2
50 Ton	18	14 3/8	18	18	0	10 5/8	7	8 3/8	9 1/8	13	11 5/8
75 Ton	20 1/2	16 1/2	20 1/2	20 1/2	0	9 7/8	5 13/16	7 3/4	7 7/8	13	13 1/2
100 Ton	20 1/4	19	20 1/4	21 1/4	0	9 7/8	6 7/16	8 3/8	8 7/8	14 1/2	15

150-ton and 250-ton dimensions supplied upon request.

* Closed height given must be increased by about 0.071" for each 1" of travel.

** Upright Type 2 closed height must be increased by about 0.071" for each 1" over the maximum given.

A and B dimensions generally increase when boots are added to jacks.

Note: Drawings are artist's conception — not for certification; dimensions are subject to change without notice.

OPTIONS BOOTS FOR BALL SCREW JACKS

For Translating Design Ball Screw Jacks

When boots are included on Joyce jacks or actuators, Joyce sizes them as part of our service to you.

Adding boots to most jacks will increase their retracted (closed) height, "A" or "B". The diagrams and chart below are provided as a reference to help you understand how the addition of standard boots increases the closed height of those jacks.

The retracted (closed) height, "A", or "B", is based on the jack capacity and it changes based on the length of travel (rise), and end condition of the lifting screw. For instance, an upright 2-ton jack with a T3 end condition and 12 inches of rise will have a greater closed dimension than the same 2-ton jack with just 3 inches of rise. Standard boot outside diameter, "C", and collar diameter at the base of the jack, "D" are listed in the chart below for reference.

Although Joyce provides the stainless steel clamps needed to secure all boots in place, customers must provide a mounting ring of the standard diameter "D" to mount the boots on inverted jacks.

When you use Joyce 2D/3D online software to specify jacks with boots the drawings will accurately depict the added screw length needed to accommodate the boot, however the actual boot will not be shown on the drawing.

Common Boot Options:

- Zippered boots • Boots for high temperatures • Boots for corrosive atmospheres

Contact Joyce for more information about these and other custom boot applications or boots for Bevel Gear Jacks.

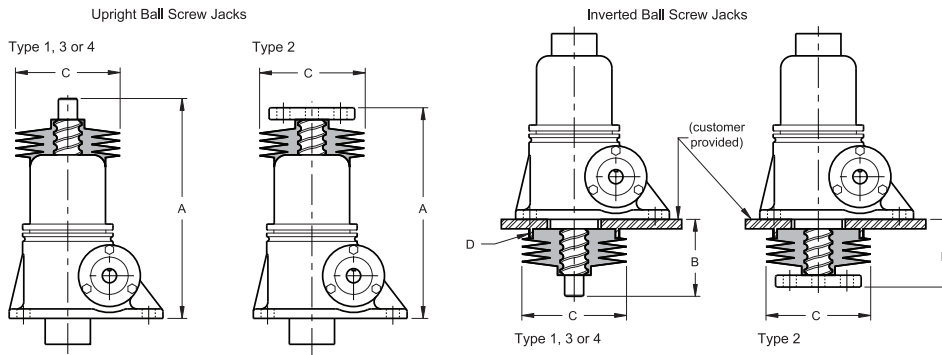

△ The closed height of Type 4 jacks remains the same up to the maximum travel given in the chart below.

Jack Capacity	A - Closed Height for Upright Jack				▲ - Type 4**	B - Closed Height for Inverted Jack				▲ - Type 4**	C O.D. of Boot	D O.D. of Boot
	Type 1*	Type 2*	Type 3*	Type 4*		Type 1*	Type 2*	Type 3*	Type 4*			
1 Ton WBL	6 7/16	6 1/4	6 7/16	7 1/4	6	2 5/8	2 1/4	2 5/8	2 7/8	0	5	2 3/4
1 Ton WB	7 7/16	7 1/4	7 7/16	8 1/4	9	2 5/8	2 1/4	2 5/8	2 7/8	0	5	2 3/4
2 Ton	8 3/8	7 3/4	8 3/8	9 5/8	12	3 1/4	2 9/16	3 1/4	3 5/8	0	5	2 3/4
5 Ton	10 1/2	11	10 1/2	13 3/8	18	3 13/16	3 5/16	3 13/16	5 3/16	0	5 1/2	4 3/4
10 Ton WBL/HWBL	11 1/4	10 5/16	11 1/4	13 1/16	15	4 7/16	3 7/16	4 7/16	5 3/16	0	6 1/2	5 3/4
10 Ton WB/HWB	15	14 1/2	15	16 3/4	18	4 15/16	3 3/4	4 15/16	5 1/2	0	6 1/2	5 3/4
20 Ton	17 3/16	16 5/8	17 3/16	20 5/16	27	4 3/4	3 7/16	4 3/4	6 1/2	9	6 1/2	6
30 Ton	23 1/4	22 9/16	23 1/4	28 5/16	42	6 1/4	4	6 1/4	10	24	8	8 1/4
50 Ton	27 3/16	26 7/16	27 3/16	32 1/2	45	6 11/16	4 15/16	6 11/16	10 1/4	21	13	11 5/8

* Closed height given must be increased by about 0.071" for each 1" of travel.

** Type 4 closed height must be increased by about 0.071" for each 1" over the maximum given.

A and B dimensions generally increase when boots are added to jacks.

Note: Drawings are artist's conception — not for certification; dimensions are subject to change without notice.

OPTIONS BOOTS FOR KFTN JACKS

For Traveling Nut Design Machine and Ball Screw Jacks

Adding single or dual boots to cover the fixed-length rotating screw on KFTN jacks usually increases the base-to-end of screw dimension due to boot stack up*. Other factors that affect boot specification include:

- Jack orientation – Upright or inverted
- Travel distance and maximum height of jack with boots (Base-to-end of screw)
- Traveling Nut (TN) orientation – TN mounted toward the jack or away from the jack
- Position and thickness of the load – Mounted above or below the flange
- Choice of dual boots, single upper boot, or single lower boot

The chart below lists standard boot diameter dimensions based on jack capacity. Working from this reference and input provided by customers about their applications, Joyce customizes boots to meet specific requirements. Please complete the worksheet on page 169 to help us understand your requirements more fully.

Although Joyce provides the stainless steel clamps needed to secure all boots in place, customers must provide mounting rings to mount boots to their structures. These customer provided mounting diameters must also be communicated to Joyce to ensure that boot collars are compatibly sized.

Common bellows boot options:

- Zippered boots • Boots for high temperatures • Boots for harsh environments

Contact Joyce for more information about these and other custom boot applications or boots for Bevel Gear® jacks.

*Boot stack up is the space required to accommodate retracted bellows boots. It can be estimated by multiplying the maximum amount of travel by 0.071". If the KFTN jack has dual boots the stack up of both boots must be considered. Contact Joyce for additional information.

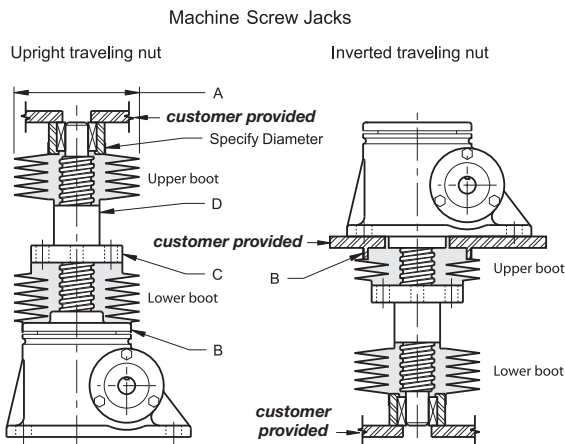

See selection guide worksheet on page 173

Jack Capacity	A O.D. of Boot	B Collar Diameter	C - Flange Collar Diameter		D - Nut Collar Diameter Machine Screw Jacks Only**
			ACME Nut	Ball Nut	
250/500 Lb.	3.5	2 5/16	2 1/4		1
1,000 Lb.	3.5	2 5/16	2 1/4		1
1 Ton	5	2 3/4	3 1/4	2 5/8	1 1/2
2 Ton	5	3 3/4	3 1/4	3 1/4	1 1/2
3 Ton	5 1/2	3 3/4	3 1/4		2
5 Ton	5 1/2	4 3/4	4	4 15/16	2
10 Ton	6 1/2	5 3/4	6	5 3/8	3
15 Ton	6 1/2	5 3/4	6 1/2		3 1/2
20 Ton	6 1/2	6	7 1/2	5 3/8	3 3/4
25 Ton	8	7 1/2	8 1/2		4 1/2
30 Ton	8	8 1/4	7 3/8	7 3/8	4 1/2
35 Ton	10	8 1/2	9		5
50 Ton	10	11 5/8	10	9 3/4	6
75 Ton	13	13 1/2	12		7
100 Ton	14 1/2	15	12 3/4		8

**Boot collars do not fit small end of ball nuts.

Note: Drawings are artist's conception — not for certification; dimensions are subject to change without notice.

SELECTION GUIDE WORKSHEET BOOTS FOR KFTN JACKS

Name _____ Title _____

Company _____ Project _____

Address _____

Phone _____ Fax _____ Email _____

Sizing boots for KFTN jacks requires additional input because many mounting configurations are possible. This worksheet is designed to help define and communicate your boot requirements. Complete the form below and submit to sales@joycedayton.com along with a sketch of your application.

Scan the QR Code to view these PDF guides online.

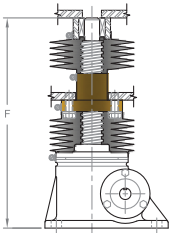
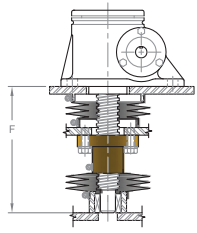

Upright Jack	Inverted Jack
	
Travel Distance _____ (F) Base-to-end of screw dimension _____	Travel Distance _____ (F) Base-to-end of screw dimension _____

Choose the image that best represents your application

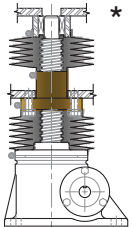
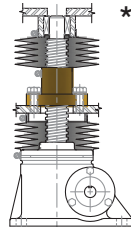
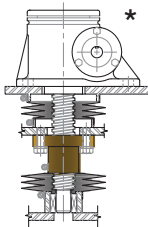
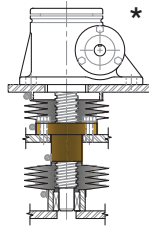
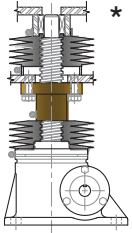
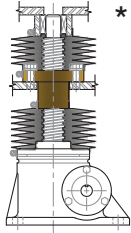
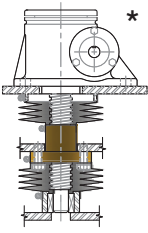
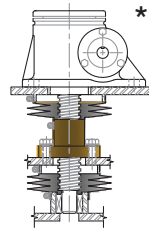
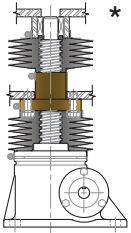
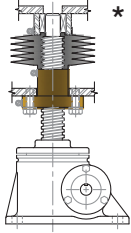
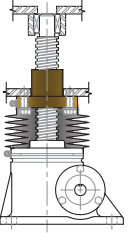
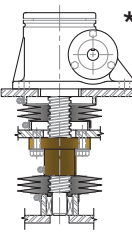
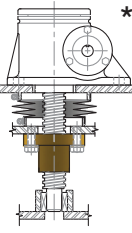
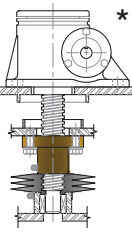
 <input type="checkbox"/> Flange toward jack Load above	 <input type="checkbox"/> Flange toward jack Load below	 <input type="checkbox"/> Flange toward jack Load above	 <input type="checkbox"/> Flange toward jack Load below		
 <input type="checkbox"/> Flange away from jack Load above	 <input type="checkbox"/> Flange away from jack Load below	 <input type="checkbox"/> Flange away from jack Load above	 <input type="checkbox"/> Flange away from jack Load below		
 <input type="checkbox"/> Dual boot	 <input type="checkbox"/> Upper boot	 <input type="checkbox"/> Lower boot	 <input type="checkbox"/> Dual boot	 <input type="checkbox"/> Upper boot	 <input type="checkbox"/> Lower boot

*Some customer provided dimensions are required from diagram on page 168.

OPTIONS LIMIT SWITCHES

Rugged Joyce limit switches allow you to set precise travel limits on Joyce jacks and actuators. They are also ideal in any application where rotary motion of a machine component can be used to indicate linear motion of another part. They are compatible with 2-ton through 150-ton jacks, electric cylinders, and integrated actuators.

LS7 Limit Switch



The LS7 limit switch has two Single-Pole, Double-Throw (SPDT) switch contacts. This switch offers a NEMA 4 rated enclosure which is rated for dust, rain and hose-directed water. To set switches, first remove the cover plate and "L" bracket, then manually rotate the cams to desired positions. This switch is also compatible with integrated actuators.

LS8 Limit Switch



The LS8 limit switch is best suited for general-purpose applications requiring up to four switch contacts for operating motors, lights and other accessories. It is available in two models: the LS8 402 (two-switch model) and the LS8 404 (four-switch model). Both LS8 models offer a NEMA 4 rated enclosure which is rated for dust, rain and hose directed water. To set the limit switches simply loosen a cam detent screw and rotate the switch trip cam to the desired position.

Note: "How to" videos can be found at joycedayton.com.



Shaft Detail

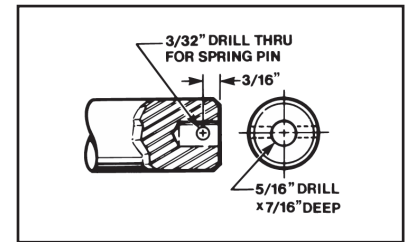

Type	Dimensions														
	A	B	C	D	E	F	G	H BG150 BB150	H BG250 BB225	H BG375 BB300	H BG450 BB400	J	K	M	N
LS7 402	3.81	6.13	1.75	5.44	5.00	5.63	1/2 NPT	7.63	9.00	10.13	15.22	7.0	3.28	3.88	2.63
LS8 402	5.50	6.62	2.00	6.75	5.25	6.25	3/4 NPT	7.88	9.25	10.38	15.47	7.62	3.53	5.25	2.46
LS8 404	6.50	8.38	2.00	8.50	6.25	8.25	1 NPT	8.62	10.00	11.19	16.47	9.62	4.53	5.25	2.46

LS8 (400 Series) Switch Combination Chart					
Switch Quantity	Single Pole Double Throw (SPDT)				
	0	1	2	3	4
D.			402		404
P.		402		404	
D.	402		404		
T.		404			
	404				

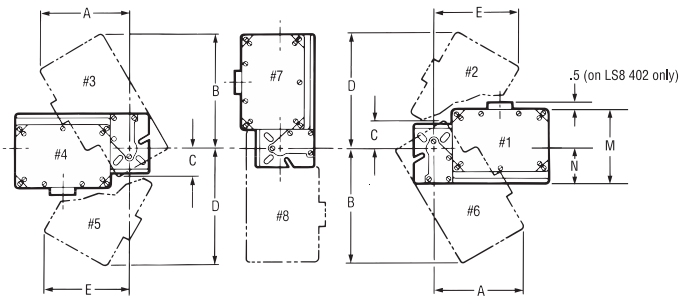

Rotation positions shown looking into end of shaft.

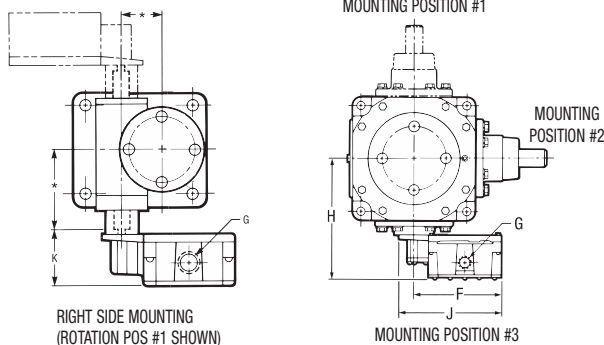

Note:

- 2, 2.5, 3, 5, 10, 15 and 20-ton jacks or electric cylinders are available with limit switch positions #1, #3, and #5.
- 25, 30, 35, 50 and 75-ton jacks are available in with limit switch positions #1, #4, #7 and #8.
- Limit switches on Bevel Gear® jacks may be mounted in any position.

OPTIONS GEARED POTENTIOMETERS

Joyce geared potentiometers are ideal for precise, accurate positioning applications. Using a 10-turn potentiometer, a signal is provided as either a change in resistance or current (when supplied with a 4-20 mA instrument transformer), which is proportional to the actual position of the screw. Geared potentiometers are commonly needed when PLCs or computers control jacks.

Geared potentiometers are available on wormgear design jacks of 2-ton to 150-ton capacity. They include a slip clutch to prevent damage due to over-rotation but should always be inspected during installation to ensure that a full range of motion is available throughout the jack travel.

As an additional option, geared potentiometers are available with upper and lower mechanical limit switches. These are common SPDT cam operated switches used for end of travel limits or set points. The standard operating voltage is less than or equal to 48 V (an operating voltage of greater than 48 V is available upon request).

Ordering information is found within specific product sections.

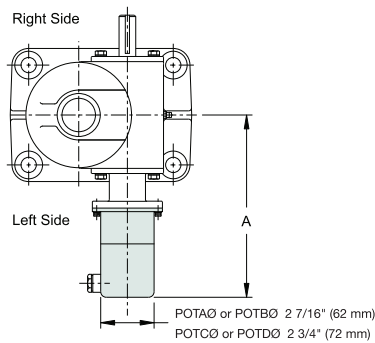

Jack Capacity	POTA and POTB "A"	POTC and POTD "A"
2 Ton	6 3/8	8 1/4
2.5 Ton	6 1/4	8
3 Ton	6 1/4	8
5 Ton	7	8 7/8
10 Ton	7 7/8	9 7/8
15 Ton	7 7/8	9 7/8
20 Ton	8 1/4	10 1/4
25 Ton	9	10 7/8
30 Ton	9	10 7/8
35 Ton	9	10 7/8
50 Ton	10 7/8	12 3/4
75 Ton	12 1/4	14 1/8
100 Ton	12 1/4	14 1/8
150 Ton	12 1/4	14 1/8

Order Codes	Descriptions	Rating
POTA	0-10 V	IP65
POTB	4-20 mA	IP65
POTC	0-10 V with 2 limit switches	IP65
POTD	4-20 mA with 2 limit switches	IP65

Instrument Transformer Characteristics (POTB and POTD)	
Supply Voltage (+U _s)	24 VDC +/- 20%
Max. Load Impedance (R _o)	<500 Ω
Output Current (I _{MESS})	4-20 mA 24 V DC ±20 %, with load ≤500*
*Standard output signal increases as screw extends	

Geared Potentiometer Electrical Characteristics	
Resistance	10 kΩ
Resistance Tolerance	+/- 5 %
Linearity Tolerance	+/- 0.25%
Load Capacity	2 W at 70°C
Standard Residual End Point Resistance	Greater of 0.2% or 1Ω
Operating Temperature	-20°C to 80°C



POTA – 0-10 VDC / POTB – 4-20mA

- 10-turn geared potentiometer with integrated slip clutch
- Model ratio is selected to maximize resolution and match shaft direction of rotation for each application at time of order
- Housing: Reinforced plastic with aluminum
- Shaft: Stainless steel
- Connector: Cable gland is standard
- Temperature rating: -4°F to 176°F (-20°C to 80°C)
- IP65 rating



POTC – 0-10 VDC / POTD – 4-20mA With limit switches

- 10-turn geared potentiometer with integrated slip clutch
- Includes 2 adjustable cam-operated limit switches
- Model ratio is selected to maximize resolution and match shaft direction of rotation for each application at time of order
- Housing: Aluminum
- Shaft: Browned steel
- Connector: Cable gland is standard
- Temperature rating: -4°F to 176°F (-20°C to 80°C)
- IP65 rating

Precise Position Sensing

Joyce can equip machine screw jacks and electric cylinders with an encoder to allow accurate position sensing within increments of 0.001 inches. The encoder combines with your control system to monitor screw travel, number of revolutions, and travel limits.

Choose from a variety of shaft-mounted encoder options, each with proven reliability and requiring virtually no maintenance. For best results, specify encoders for jacks and electric cylinders and have them factory mounted to meet your requirements.

Consider and compare encoder options on page 173 then select the best one for your application. Mating connector cables can be purchased separately. For custom options contact Joyce.

Complete ordering information is available within product sections.

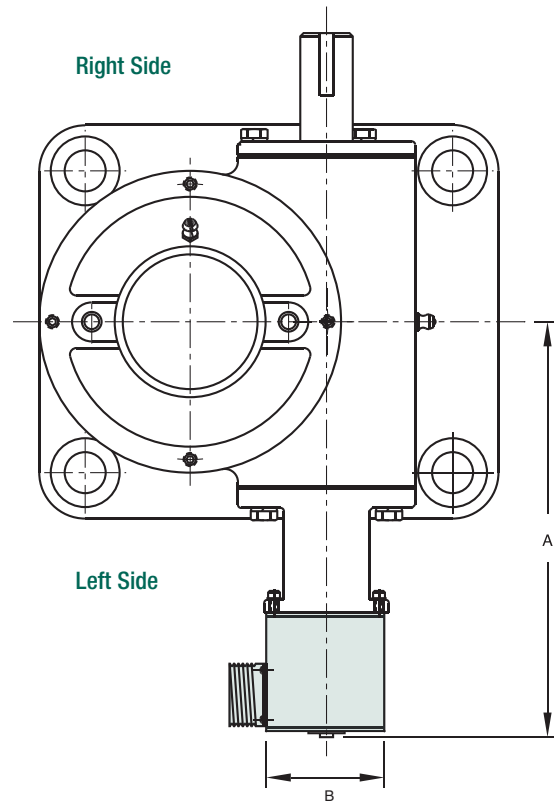

Jack or Electric Cylinder Capacity	ENCA & ENCB		ENCC & ENCD		ENCS		ENCX & ENCY	
	A	B	A	B	A	B	A	B
2 Ton	5.38	2.31 Dia.	6.34	2.5 Dia.	5.84	2.0 Dia.	5.84	2.25 Sq.
2.5 Ton	6.38	2.31 Dia.	7.38	2.5 Dia.	6.88	2.0 Dia.	6.88	2.25 Sq.
3 Ton	6.38	2.31 Dia.	7.38	2.5 Dia.	6.88	2.0 Dia.	6.88	2.25 Sq.
5 Ton	6.38	2.31 Dia.	7.38	2.5 Dia.	6.88	2.0 Dia.	6.88	2.25 Sq.
10 Ton	7.50	2.31 Dia.	8.44	2.5 Dia.	7.94	2.0 Dia.	7.94	2.25 Sq.
15 Ton	7.50	2.31 Dia.	8.44	2.5 Dia.	7.94	2.0 Dia.	7.94	2.25 Sq.
20 Ton	7.88	2.31 Dia.	8.81	2.5 Dia.	8.31	2.0 Dia.	8.31	2.25 Sq.
25 Ton	8.38	2.31 Dia.	9.38	2.5 Dia.	8.88	2.0 Dia.	8.88	2.25 Sq.
30 Ton	8.38	2.31 Dia.	9.38	2.5 Dia.	8.88	2.0 Dia.	8.88	2.25 Sq.
35 Ton	8.38	2.31 Dia.	9.38	2.5 Dia.	8.88	2.0 Dia.	8.88	2.25 Sq.
50 Ton	10.50	2.31 Dia.	11.44	2.5 Dia.	10.94	2.0 Dia.	10.94	2.25 Sq.
75 Ton	11.75	2.31 Dia.	12.63	2.5 Dia.	12.13	2.0 Dia.	12.13	2.25 Sq.
100 Ton	11.75	2.31 Dia.	12.69	2.5 Dia.	12.19	2.0 Dia.	12.19	2.25 Sq.
150 Ton	11.75	2.31 Dia.	12.69	2.5 Dia.	12.19	2.0 Dia.	12.19	2.25 Sq.

Note: Drawings are artist's conception — not for certification; dimensions are subject to change without notice.

Absolute Encoder with Programmable Operating Ranges ENCA / ENCB



- ENCA 0-10 VDC output, M12 connection (A-coded)
- ENCB 4-20mA output, M12 connection (A-coded)
- Multi-turn absolute analog encoder with 12-bit resolution over the measuring range
- Programmable operating ranges
- A single model has universal application up to 65,536 turns of the jack or actuator
- Stainless steel (nickelized) housing: Stainless steel shaft
- IP64
- Temperature rating: -40° F to 185° F (-40°C to 85°C)

ENCA/ENCB

Function 5-pin M12	Pin Connections
I _{out} /U _{out}	1
+ UB	2
Ground	3
Limit 1	4
Limit 2	5

Absolute Encoder ENCC / ENCD



- ENCC (Binary) CAN open output, 5-pin M12 connection
- ENCD (Gray) SSI output, 8-pin M12 connection
- Model selected based on required number of turns up to 262,144
- Multi-turn absolute encoder with 18-bit resolution
- Black non-corrosive finish on housing: 303 Stainless steel shaft
- IP67
- Temperature rating: -40° F to 176° F (-40°C to 80°C)

ENCC (Absolute)

Function 5-pin M12	Pin Connections
CAN open - Binary	
CAN GND/shield	1
+ VDC	2
Ground	3
CAN high	4
CAN low	5

ENCD (Absolute)

Function 8-pin M12	Pin Connections
SSI -Gray	
Ground	1
+VDC	2
SSI CLK+	3
SSI CLK-	4
SSI Data +	5
SSI Data -	6
Preset	7
DIR	8

Stainless Steel Incremental Encoder ENCS



- ENCS 1024 PPR, Quadrature output, 5-pin M12 connection
- Multi-turn encoder
- This encoder model permits an unlimited number of turns
- Compatible with most programmable controllers
- 316 Stainless steel housing: 316 Stainless steel shaft
- IP67
- Temperature rating: -40° F to 158°F (-40°C to 70°C)

ENCS (Incremental)

Function 5-pin M12	Pin Connections
+ VDC	1
B	2
Common	3
A	4
Z index	5

Standard Incremental Encoder ENCX / ENCY



- ENCX 200 PPR, Quadrature output, 6- Pin M5 connection
- ENCY 1024 PPR, Quadrature output, 6-pin M5 connection
- Multi-turn Encoder
- This encoder model permits an unlimited number of turns
- Black non-corrosive finish on housing: 303 Stainless steel shaft
- 6-pin MS connection
- Temperature rating: 32° F to 158 °F (0°C to 70°C)

ENCX & ENCY (Incremental)

Function 6-pin MS	Pin Connections
Common	A, F
+VDC	B
A	D
B	E
Z	C

Note: Drawings are artist's conception — not for certification; dimensions are subject to change without notice.

OPTIONS SERVO MOTOR MOUNTS

Joyce offers servo motor mounts for 2, 2-1/2, 3, 5, and 10-ton worm gear screw jacks and electric cylinders. Easily attach the motor of your choice to either side of your jack. These mounts are compatible with various servo motors but Joyce can provide servo motor mounts to meet your exact specifications.

Contact Joyce today and allow us to provide motor mounts that meet your servo motor specifications.

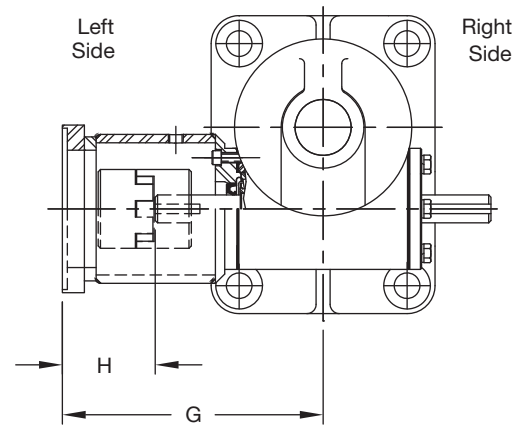
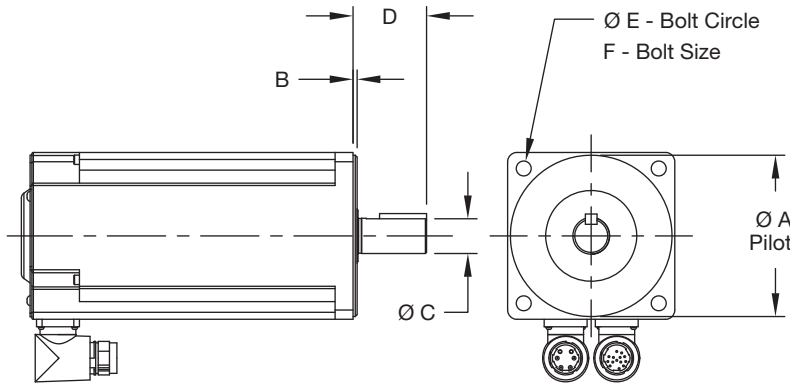

Motor Frame Dimensions (mm)						
Shaft Code	A	B	C	D	E	F
SM01	80.0	2.74	16.0	40.0	100.0	M6x1.00
SM02	95.0	2.74	19.0	40.0	115.0	M8x1.25
SM03	110.0	2.74	24.0	50.0	130.0	M8x1.25
SM04	110.0	2.74	24.0	50.0	130.0	M8x1.25
SM05	130.0	3.12	28.0	60.0	165.0	M10x1.50
SM06	130.0	3.12	28.0	60.0	165.0	M10x1.50

Jack Dimensions (mm)				
Jack Model	Shaft Code	G	H	Max. Coupling Torque N-m
2 Ton Reverse Base, 2-1/2, & 3 Ton	SM01	137.0	52.8	15.2
	SM02	142.0	53.0	24.4
	SM03	152.0	63.0	32.8
	SM04	157.0	68.0	60.0
	SM05	161.8	72.9	32.8
	SM06	167.8	78.9	60.0
5 Ton	SM01	162.7	52.6	15.2
	SM02	167.6	53.3	24.4
	SM03	177.8	63.4	32.8
	SM04	182.8	68.5	60.0
	SM05	187.5	73.2	32.8
	SM06	193.4	79.1	160.0
10 Ton	SM02	193.4	53.7	24.4
	SM04	207.8	68.1	60.0
	SM05	213.2	73.5	32.8
	SM06	219.2	79.5	160.0

Note: Drawings are artist's conception — not for certification; dimensions are subject to change without notice.

OPTIONS MOTOR MOUNTS AND STOCK MOTORS

Joyce motor mounts allow direct coupling to the motor shaft on either the right (shown) or left side jack input shaft. For easy installation 2-ton through 20-ton wormgear style jacks are available with motor mount adapters for standard NEMA C-Face motors. Jacks supplied with motor mounts are available with and without NEMA C-Faced motors. When motors are included they come with the necessary hardware and coupling keys. Contact Joyce for information about other types of motor mounts (i.e., IEC, pneumatic, etc.).

Motor Mount Dimensions			
Capacity	NEMA Frame Size	A	B
2 ton	56C	6.25	.50
	140TC		
2.5 ton	56C	6.25	.50
	140TC		
3 ton	56C	6.25	.50
	140TC		
5 ton	56C	7.25	.50
	140TC	7.25	.50
	180TC	8.00	.63
10 ton	56C	8.25	.50
	140TC	8.25	.50
	180TC	9.00	.63
15 ton	56C	8.25	.50
	140TC	8.25	.50
	180TC	9.00	.63
20 ton	56C	8.25	.50
	140TC	8.25	.50
	180TC	9.00	.63
	210TC	9.75	.88

Motor Dimensions					
HP	NEMA Frame Size	C	D	E	F
1/3	56C	7.06	9.31	5.94	4.25
1/2	56C	7.06	9.31	5.94	4.25
3/4	56C	7.06	9.31	5.94	4.25
1	143TC	7.19	10.25	6.34	4.56
1 1/2	145TC	7.19	10.25	6.34	4.56
2	145TC	7.19	11.25	6.34	4.56
3	182TC	9.06	17.38	7.50	4.56
5	184TC	9.06	18.75	7.50	4.56
7 1/2	213TC	10.85	15.81	7.50	8.25

Ordering information is found within specific product sections.

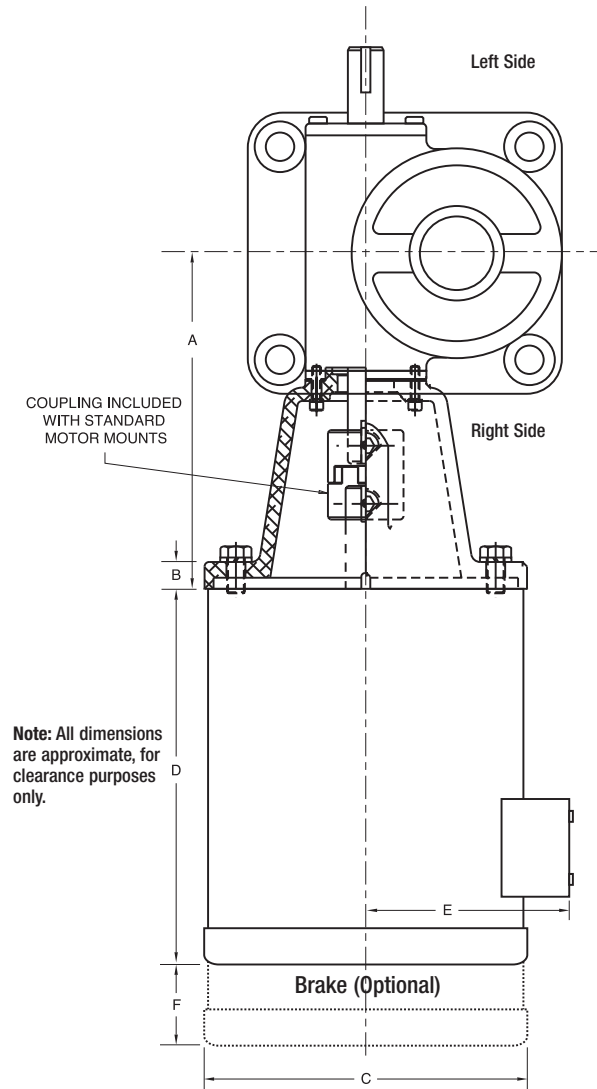

- All standard motors are 3-phase, 60 Hz., 208-230/460 VAC or 230/460 VAC. Other motor options are available. Contact Joyce for motor speeds that exceed 1750 RPM.
- It is important to consider the input torque a direct drive motor must deliver at start up.
- Brake motors (M2) are recommended for double lead jacks, ball screw jacks and actuators, and electric cylinders that are more than 30% efficient.
- If the motor frequency will be varied to provide a “soft” start, an inverter duty motor may be needed.

NOTE: JAX® Online software may be used to size direct-drive motors, but users are advised to evaluate motor start-up torque requirements and adjust motor horsepower accordingly. Contact Joyce for assistance.

Note: Drawings are artist's conception — not for certification; dimensions are subject to change without notice.

OPTIONS HAND WHEELS AND COUNTERS

		Hand Wheel Dimensions				
Jack Capacity	Dimension	4" Diameter HW04	6" Diameter HW06	8" Diameter HW08	10" Diameter HW10	12" Diameter HW12
250, 500 Lb. and 1,000 Lb.	A	4 5/8	6 1/8			
	B	1	2			
	C	3/8	3/4			
1 Ton	A	5 3/8	6 7/8	7 5/8	8 1/2	8 7/8
	B	1/2	1 1/2	2 1/2	3 1/2	4 1/2
	C	5/8	1	1 3/8	1 7/8	2 1/4
2 Ton Standard Base	A	5 7/8	7 1/4	8	9	9 1/4
	B	1/4	1 1/4	2 1/4	3 1/4	4 1/4
	C	0	3/8	3/4	1 1/4	1 5/8
2 Ton Reverse Base	A	5 3/4	7 1/4	8	9	9 1/4
	B	1/4	1 1/4	2 1/4	3 1/4	4 1/4
	C	1 3/4	2 1/8	2 1/2	3	3 3/8
2.5 Ton	A	5 3/4	7 1/4	8	9	9 1/4
	B	1/4	1 1/4	2 1/4	3 1/4	4 1/4
	C	1 1/2	1 7/8	2 1/4	2 3/4	3 1/8
3 Ton	A	5 3/4	7 1/4	8	9	9 1/4
	B	1/4	1 1/4	2 1/4	3 1/4	4 1/4
	C	1 1/2	1 7/8	2 1/4	2 3/4	3 1/8
5 Ton	A	6 3/8	7 3/4	8 3/4	9 1/2	10
	B	0	3/4	1 3/4	2 3/4	3 3/4
	C	1 1/8	1 1/2	1 7/8	2 3/8	2 3/4
10 Ton	A			9 3/8	10 1/4	10 5/8
	B			1 3/4	2 3/4	3 3/4
	C			1 7/8	2 3/8	2 3/4
15 Ton	A			9 3/8	10 1/4	10 5/8
	B			1 1/4	2 1/4	3 1/4
	C			1 3/4	2 1/4	2 5/8
20 Ton	A			9 3/8	10 1/4	10 5/8
	B			3/4	1 3/4	2 3/4
	C			1 1/2	2	2 3/8

These aluminum hand wheels are only recommended for self-locking jacks.



		Counter Dimensions					
Dimension	Jack Capacity						
	2 Ton	2.5 Ton	3 Ton	5 Ton	10 Ton	15 Ton	20 Ton
D	4 1/2	4 1/2	4 1/2	5	5 7/8	5 7/8	6

Standard count increases as lifting screw extends, longer worm shafts are available. Ordering information is found within specific product sections.

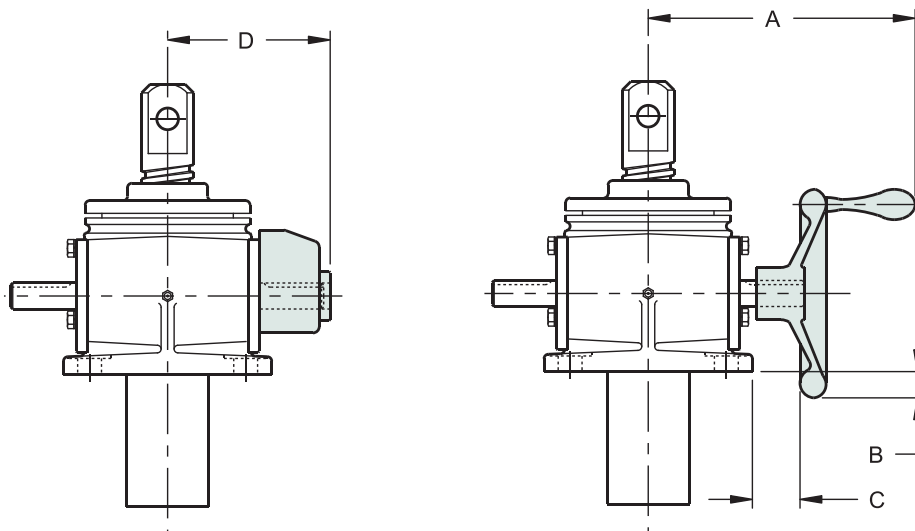

Note: Drawings are artist's conception — not for certification; dimensions are subject to change without notice.

OPTIONS ANTI-BACKLASH DESIGNS

Anti-Backlash Designs

Anti-backlash devices are internal jack components used to minimize backlash (free movement between the lifting screw and nut) in machine screw jacks. These devices are used in reversing load applications where the lifting screw position is critical.

These devices are frequently used in steel mill applications where the screw jacks are used to set and maintain the position of the movable upper roll of a rolling mill. In operation, the initial weight of the roll pulls the lifting screw to one side of the internal nut. When steel passes through the rolls, the load reverses on the lifting screw and movement in the opposite direction is limited by the anti-backlash device.

Other common applications include screw jacks used to position communication antennas and solar panels. In these applications, directional changes in the wind can buffet the panels thus affecting the position of the lifting screw. During high wind conditions, anti-backlash devices minimize the lifting screw movement.

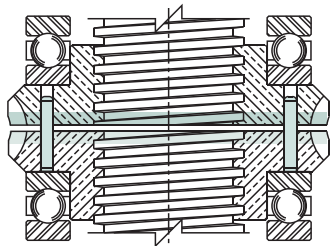

A-Split Gear Design

- Best suited for light dynamic loads (1/3 jack capacity or less) and full jack capacity for static loads.
- A split gear and dowel pins maintain gear alignment.
- Adjustments are made by tightening the sleeve (housing) cap.
- Typically reduces endplay to 0.010" — 0.015" without increased torque.*
- Available on translating models, 500-pound to 75-ton (upright and inverted) jacks.
- Available on some keyed models. Contact Joyce.
- Order using an "A" designation in the suffix of the part number.

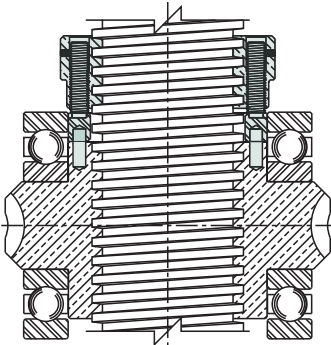

A90 Design

- Best suited for medium dynamic loads (1/2 to 3/4 jack capacity) and full jack capacity for static loads.
- This design incorporates a hardened steel plate pinned to the top of the internal gear and a secondary nut placed above the steel plate.
- Setting the backlash is accomplished by tightening the dog point set screws located inside the secondary nut. The set screws are externally adjustable.
- Typically reduces endplay to 0.008" — 0.012" without increased torque.*
- Available on upright translating models, 25-ton to 100-ton capacity jacks.
- Available on some keyed models. Contact Joyce.
- Order using an "A90" designation in the suffix of the part number.

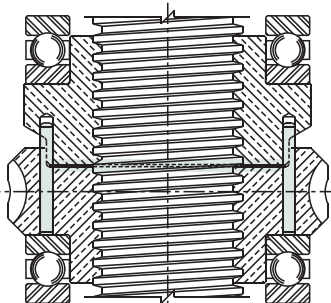

A95 Design

- Capable of handling full jack capacity in dynamic as well as static conditions.
- This design allows the gear teeth to remain intact and therefore retain their full load carrying capacity.
- Adjust endplay by tightening the sleeve (housing) cap.
- Typically reduces endplay to 0.008" — 0.012" without increased torque.*
- Available on upright and inverted translating models, 2-ton to 150-ton capacity jacks.
- Order using an "A95" designation in the suffix of the part number.

*If the backlash is set below the recommended values, torque values will increase significantly and thread wear will accelerate.
Ordering information is found within specific product sections.

Note: Drawings are artist's conception — not for certification; dimensions are subject to change without notice.

Finishes for Jack Housings

- Gray enamel is the standard finish for Joyce jacks (2-ton and larger) and electric cylinders.
- Miniature jacks with aluminum housings (WJ250, WJ500, WJ1000, WJ51, WJ201, WBL51, WB51, WBL201, & WB201), linear actuators, and integrated actuators are unpainted.
- Standard epoxy (F2) is comprised of a two-component polyamide primer, and a two-component low VOC, polyurethane topcoat (available in green and white).
- STEEL IT® epoxy finish provides a hard, non-toxic finish. It is comprised of a two-part, lead-free epoxy primer with a two-part polyamide epoxy topcoat (which incorporates 316 stainless steel leafing pigment). Approved by USDA for use where incidental food contact may occur.
- Joyce outdoor paint process (F3), is an exclusive paint process that protects against corrosion due to harsh outdoor environments. It incorporates rigorous surface preparation with a premium epoxy primer and topcoat and stainless steel hardware resulting in a durable, corrosion-resistant finish that is in high demand on antenna jacks, solar jacks, mining industry jacks and jacks used in coastal installations.
- Clear coat anodizing is a uniform coating process that increases the corrosion resistance and wear properties of aluminum housings. It will not flake or peel.
- Electroless nickel plating is a thin, uniform coating. When applied to jack housing, it provides superior corrosion resistance and improved wear resistance, while having little effect on the fit of mating components.

Material and Finishes for Lifting Screws

- Stainless steel lifting screws are standard on WJ250, WJ500, WJ1000, and for all stainless steel jacks. They are available for machine screw jacks, bevel gear jacks, metric jacks, and traveling nut (TN) style integrated actuators.
- Armoloy®, a thin, dense chrome finish, intended to increase wear and corrosion resistance, and improve lubricity. It can also be applied to stainless steel components for superior corrosion resistance. This thin coating (0.0001" — 0.0003") has little effect on the fit of mating components.
- Xylan® coating, which uses a combination of fluoropolymer lubricants and resin binders, significantly reduces the coefficient of friction of components and offers excellent corrosion protection and good chemical resistance. The application of this coating (0.0002" — 0.0007") has little effect on the fit of mating parts.

Finishes for Input Shafts, Clevis Ends, and Other Components

- Stainless steel worm shafts, standard on WJ250, WJ500, WJ1000, and for all stainless steel jacks, are available as an option on most wormgear style jacks.
- Armoloy®, a thin, dense chrome finish, intended to increase wear and corrosion resistance, and improve lubricity. It can also be applied to stainless steel components for superior corrosion resistance. This thin coating (0.0001" — 0.0003") has little effect on the fit of mating components.
- Electroless nickel plating is a thin, uniform coating. When applied to worm and pinion input shafts, it provides superior corrosion resistance and improved wear resistance, while having little effect on the fit of mating components.
- Zinc coating provides protection against corrosion, increases surface lubricity, and improves the aesthetic appearance of components. The effect it has on the fit of mating components is dependent on the thickness of its application (0.0002" — 0.0010").



Standard Enamel Finish



STEEL IT® Epoxy



Standard Epoxy



Electroless Nickel Finish

To order special finishes and materials, contact Joyce.

OPTIONS TRUNNION MOUNTS

Options – Trunnion Mounting Adapters

Trunnion adapter plates bolt to the base of 2-ton through 20-ton jacks. They include precision bores for trunnion pins. These are frequently used in installations where a single* jack moves through an arc during operation. This jack is often configured with a motor mount or as a ComDRIVE®.

Design Information

The customer supplied trunnion pins should be ground to the “D” diameter shown in the table below. These pins should be made of steel with hardness greater than 30 HRC, a yield strength greater than 60,000 psi and be supported to within 1/16 inch of the trunnion adapter plate. Therefore, the distance between the customer’s mounting surfaces should be no more than “A” + 0.13 inch.

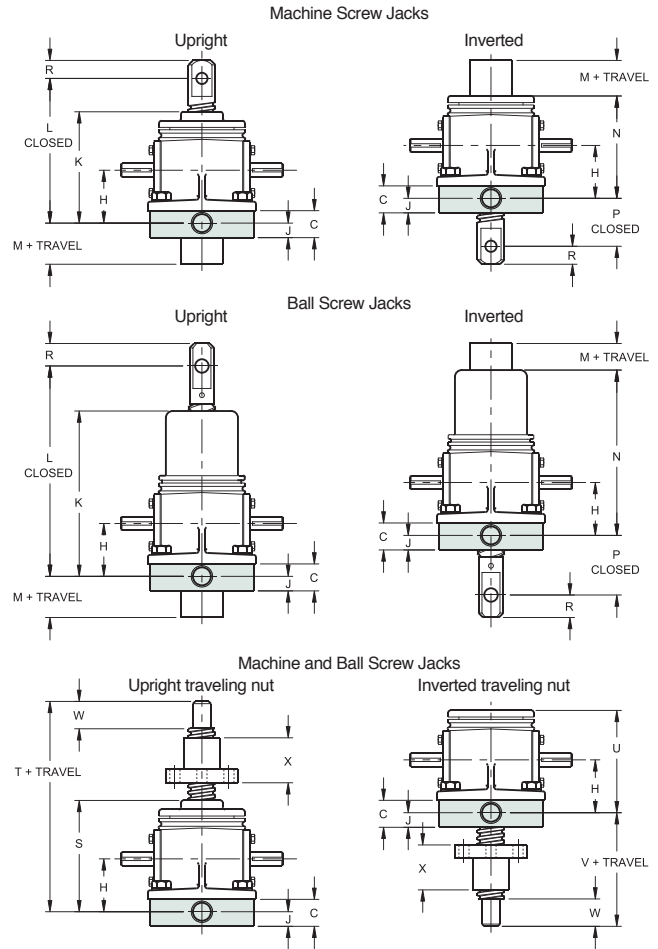
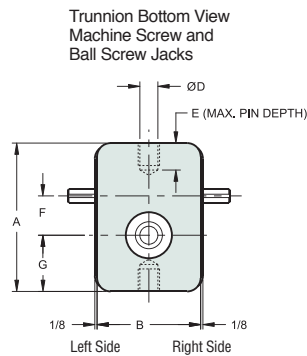

Jack Model	Common Dimensions										Upright - Inverted						Upright - Inverted Traveling Nut					
	A	B	C	D	E	F	G	H	J	K	L	M	N	P	R	S	T	U	V	W	X	
Machine Screw	2 Ton RWJT/DRWJ	7 1/4	3 1/4	1 1/4	.7491 .7479	1 1/4	1.703	3 1/8	2 5/16	11/16	4 11/16	5 3/8	0	4 5/16	2 1/16	11/16	4 11/16	8 3/16	4 3/4	4 13/16	1 1/16	1 1/2
	3 Ton WJ/DWJ	6 1/2	3 7/8	1 1/4	.7491 .7479	1 1/4	1.750	2 1/2	2 5/16	11/16	4 3/8	6 5/8	1/8	4 3/8	2 3/8	3/4	4 3/8	8 1/8	4 3/8	5 1/8	3/4	2
	5 Ton WJT/DWJ	8 1/4	5 3/4	1 1/2	.9991 .9979	1 1/2	2.188	3 1/8	2 15/16	13/16	6 3/16	7 3/16	0	5 11/16	1 13/16	1	6 3/16	11 3/16	6 3/16	6 13/16	1 1/2	2 1/2
	10 Ton WJ/DWJ	9	7 1/4	2	1.2488 1.2472	1 1/2	2.598	3	3 1/8	1 1/8	6 1/8	7 1/2	0	6	2 1/2	15/16	6 1/8	13 1/8	6 1/8	8 7/8	1 31/32	3
	15 Ton WJ/DWJ	9 1/2	7 1/2	2 1/4	1.4988 1.4972	1 3/4	2.598	3 1/2	3 3/4	1 1/4	7	8 3/8	0	6 7/8	2 5/8	15/16	7	13	7	7 11/16	1 31/32	3
	20 Ton WJ/DWJ	11 1/4	8	2 1/4	1.4988 1.4972	1 3/4	2.598	4 1/4	4 1/4	1 1/4	8 1/4	9 5/8	0	8 1/4	2 5/8	1 3/8	8 1/4	14 1/4	8 1/4	8	1 15/16	3
Ball Screw	2 Ton RWB/RHWB	7 1/4	3 1/4	1 1/4	.7491 .7479	1 1/4	1.703	3 1/8	2 5/16	11/16	7	9 7/16	9/16	7	2 9/16	3/4	4 11/16	9 7/16	4 11/16	6 1/16	1 1/8	3 1/8
	5 Ton WB	8 1/4	5 3/4	1 1/2	.9991 .9979	1 1/2	2.188	3 1/8	2 15/16	13/16	9 7/16	12 3/4	11/16	9 7/16	4 3/4	1 1/4	6 3/16	12 3/16	6 3/16	7 1/2	1 1/8	4 1/2
	5 Ton HWB	8 1/4	5 3/4	1 1/2	.9991 .9979	1 1/2	2.188	3 1/8	2 15/16	13/16	9 7/16	12 3/4	11/16	9 7/16	4 3/4	1 1/4	6 3/16	11 5/8	6 3/16	6 15/16	1 1/8	3 25/32
	10 Ton WBL	9	7 1/4	2	1.2488 1.2472	1 1/2	2.598	3	3 1/8	1 1/8	9 9/16	12 3/4	11/16	9 9/16	3	1 1/4	6 1/8	12 3/4	6 1/8	8 7/16	1 3/4	4 1/2
	10 Ton HWBL	9	7 1/4	2	1.2488 1.2472	1 1/2	2.598	3	3 1/8	1 1/8	9 9/16	12 3/4	11/16	9 9/16	3	1 1/4	6 1/8	12 3/16	6 1/8	7 7/8	1 3/4	3 25/32
	10 Ton WB/HWB	9	7 1/4	2	1.2488 1.2472	1 1/2	2.598	3	3 1/8	1 1/8	13 1/8	16 3/8	11/16	13 1/8	3 1/8	1 1/4	6 1/8	15 5/16	6 1/8	10 3/8	2	6 5/8
20 Ton WB	11 1/4	8	2 1/4	1.4988 1.4972	1 3/4	2.598	4 1/4	4 1/4	1 1/4	15 3/16	19 7/8	3/8	15 3/16	4	1 1/2	8 1/4	18 1/4	8 1/4	12	2 3/4	6 3/4	

Trunnion adapters mounted to inverted jacks will decrease the minimum closed dimension and may shorten the travel.

*Contact Joyce if multiple trunnion-mounted jacks will be used in a system.

Note: Drawings are artist’s conception — not for certification; dimensions are subject to change without notice.

ACCESSORIES PILLOW BLOCKS AND FLANGE BLOCKS

Joyce ductile iron pillow blocks and flange blocks include self-aligning replaceable bearings that are pre-lubricated with lithium grease. They include steel retainers and nitrile rubber seals with steel guards.

Pillow blocks and flange blocks are suitable for shaft supports and bearing supports for rotary screws on KFTN jacks under normal duty operation.

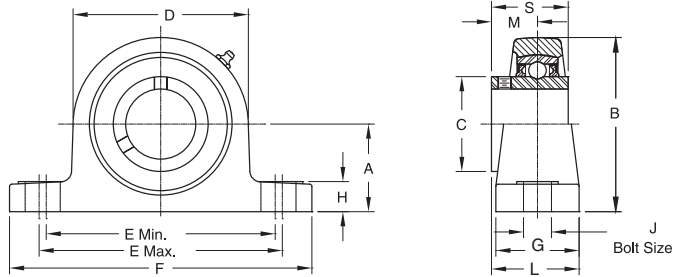

2 Bolt Pillow Blocks – Ductile Iron Housing – For Low Shaft Height – Setscrew Lock – Wide Inner Ring

Part Number	Shaft Size	A	B	C	D	E Min.	E Max.	F	G	H	J	L	M	S	Wt. Lbs.
PB-050	1/2	1 1/16	2 1/8	0.969	2 1/4	3 3/8	3 5/8	4 3/4	1 3/8	33/64	3/8	1 5/16	0.626	1.079	1.2
PB-063	5/8														
PB-075	3/4	1 1/4	2 1/2	1.142	2 5/8	3 3/4	3 31/32	5 1/32	1 1/2	35/64	3/8	1 15/32	0.720	1.220	1.9
PB-100	1	1 5/16	2 5/8	1.339	2 25/32	4	4 1/4	5 1/2	1 9/16	19/32	3/8	1 9/16	0.776	1.339	2.4
PB-125	1 1/4	1 13/16	3 19/32	1.843	3 27/32	4 13/16	5 3/16	6 9/16	1 7/8	45/64	1/2	1 15/16	1.000	1.689	3.8
PB-144	1 7/16														
PB-150	1 1/2	1 15/16	3 27/32	2.063	4 3/16	5 5/16	5 11/16	7 1/8	2 1/16	3/4	1/2	2 7/32	1.189	1.937	4.8
PB-169	1 11/16	2 1/16	4 1/8	2.260	4 17/32	5 9/16	5 15/16	7 7/16	2 1/8	25/32	1/2	2 1/4	1.189	1.937	5.4
PB-175	1 3/4														
PB-200	2	2 7/16	4 27/32	2.705	5 5/16	6 7/8	7 3/8	9 1/8	2 3/8	29/32	5/8	2 1/2	1.315	2.189	8.7

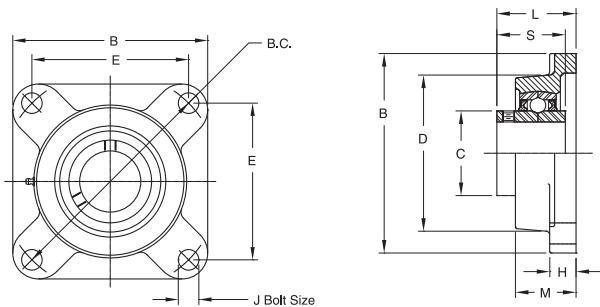

4 Bolt Flange Blocks – Ductile Iron Housing – Setscrew Lock – Wide Inner Ring

Part Number	Shaft Size	B	B.C.	C	D	E	H	J	L	M	S	Wt. Lbs.
FB-050	1/2	3	3	.969	2 3/32	2 1/8	7/16	3/8	1 7/32	31/32	1.079	1.0
FB-063	5/8											
FB-075	3/4	3 3/8	3 5/8	1.142	2 3/8	2 1/2	19/32	3/8	1 15/32	1 5/32	1.220	1.5
FB-088	7/8	3 21/32	3 57/64	1.339	2 3/4	2 3/4	19/32	7/16	1 17/32	1 3/16	1.339	1.9
FB-100	1											
FB-125	1 1/4	4 9/16	5 1/8	1.843	3 9/16	3 5/8	11/16	1/2	1 27/32	1 3/8	1.689	4.4
FB-144	1 7/16											
FB-150	1 1/2	5 3/32	5 43/64	2.063	4 1/32	4	11/16	1/2	2 1/8	1 17/32	1.937	5.6
FB-175	1 3/4	5 5/16	5 27/32	2.260	4 1/4	4 1/8	23/32	1/2	2 1/8	1 9/16	1.937	6.0

Note: Drawings are artist's conception — not for certification; dimensions are subject to change without notice.

ACCESSORIES MITER GEAR BOXES

Joyce miter gear boxes are specifically engineered for use with Joyce jacks and actuators in multiple jack systems. Miter gear boxes used in such systems effectively raise unevenly distributed loads. When driven shaft turns per inch of travel are the same, total synchronization is assured because all models have a uniform lifting speed. Arrows in assembly drawings below indicate shaft rotation.

Standard Joyce miter gear boxes are available in 1:1 and 2:1 ratios. Other ratios are available in the RC series units. Four-shaft units are also available in the RC-18 through RC-204 and the MKA.

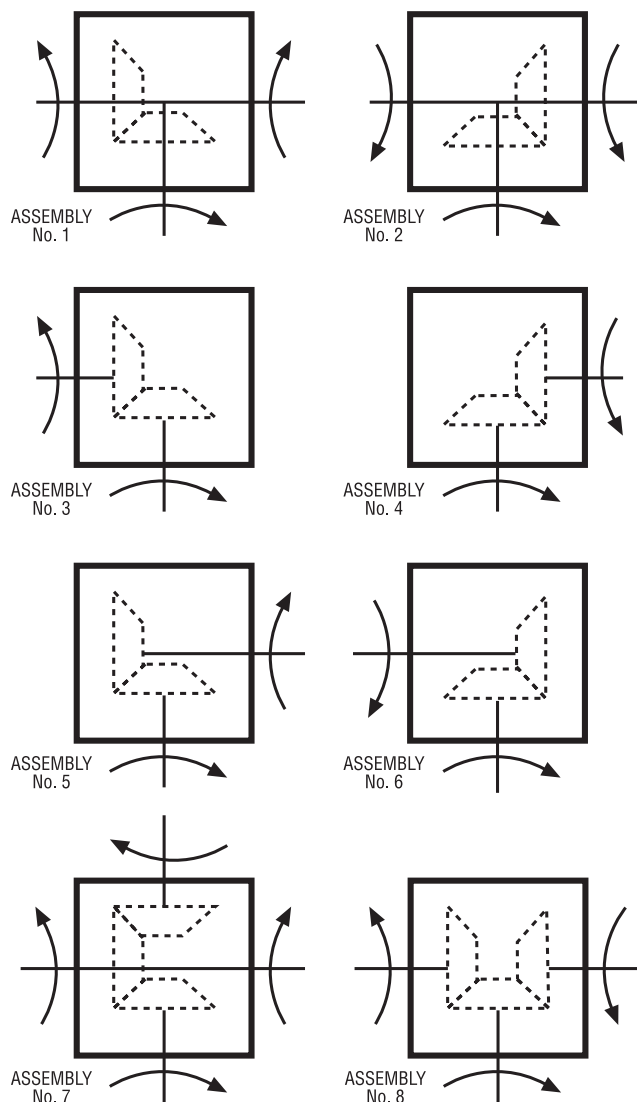

Assembly No. 7 and 8 availability:

RC-18 RC-38
RC-99 RC-204
MKA

Note: Drawings are artist's conception — not for certification; dimensions are subject to change without notice. When ordering miter gear boxes specify model numbers and assembly numbers.

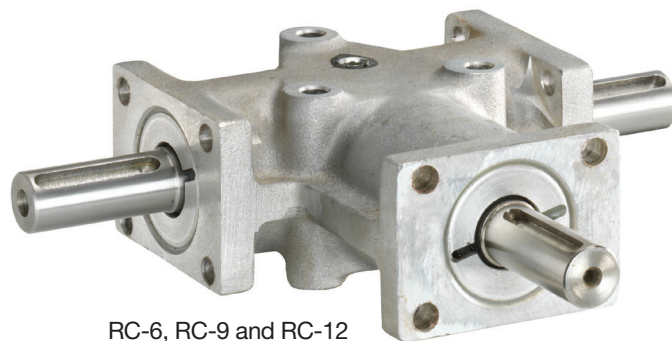

RC-6, RC-9 and RC-12



RC-15 through RC-204



MKA

ACCESSORIES MITER GEAR BOXES

RC-6 THROUGH RC-12

Lubrication

Units are lifetime lubricated.

RC-6 shafts feature flats (shown below).

RC-9 and RC-12 models have keyways.

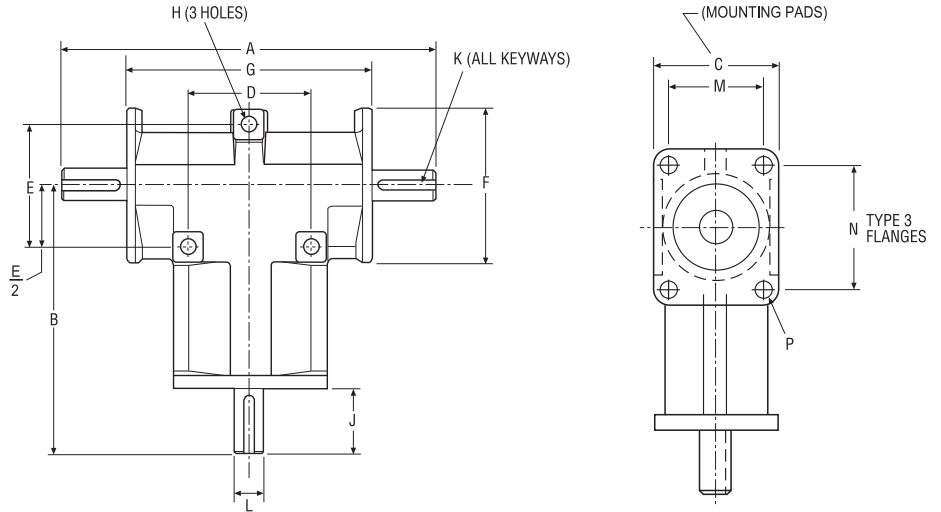
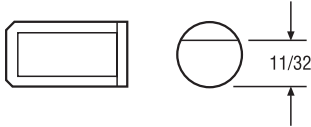

Model No.	Ratio	Max. Torque Rating (In. Lbs.)*	Max. HP @ 400 RPM	Max. RPM	A	B	C	D	E	F	G	H	J	K	L	M	N	P	Approx. Wt. (Lbs.)
RC-6	1:1	36	0.21	5,000	4 5/16	2 15/16	1 1/4	1 5/16	1 5/16	1 5/8	2 3/4	7/32	25/32		3/8	7/8	1 3/16	3/16	3/4
RC-6	2:1	12	0.06	5,000	4 5/16	2 15/16	1 1/4	1 5/16	1 5/16	1 5/8	2 3/4	7/32	25/32		3/8	7/8	1 3/16	3/16	3/4
RC-9	1:1	130	0.75	5,000	7 3/8	4 13/16	2	1 7/8	1 7/8	2 1/2	4 1/4	9/32	1 9/16	3/16 x 1 3/8	5/8	1 3/8	1 7/8	9/32	3
RC-9	2:1	51	0.30	5,000	7 3/8	4 13/16	2	1 7/8	1 7/8	2 1/2	4 1/4	9/32	1 9/16	3/16 x 1 3/8	5/8	1 3/8	1 7/8	9/32	3
RC-12	1:1	382	2.17	5,000	9 1/8	6 9/16	3	3	3	3 7/8	6	3/8	1 9/16	3/16 x 1 3/8	3/4	2 1/4	3	3/8	8
RC-12	2:1	148	0.85	5,000	9 1/8	6 9/16	3	3	3	3 7/8	6	3/8	1 9/16	3/16 x 1 3/8	3/4	2 1/4	3	3/8	8

* Torque @ 100 RPM and 750 hours of life.

RC-15

Lubrication

Fill with 6 ounces. EP-90 gear oil for normal operation. Units are shipped less lubricant.

Dimensions are representative of 1:1 ratio miter boxes.

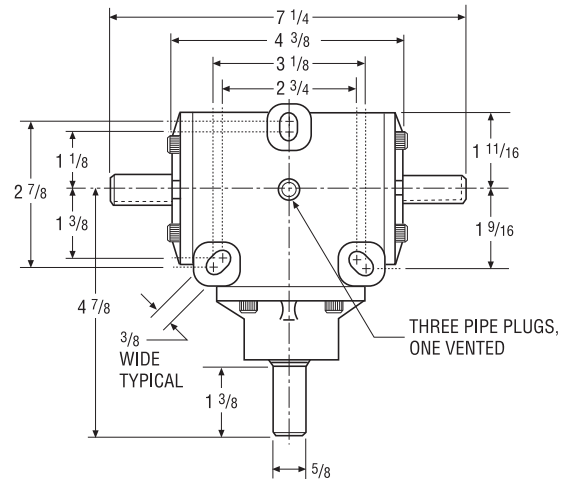
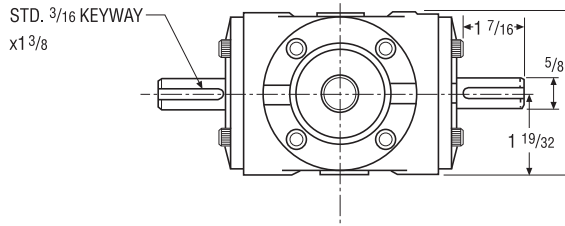

Model No.	Ratio	Max. Torque Rating (In. Lbs.)*	Max. HP @ 400 RPM	Max. RPM	Approx. Weight (Lbs.)
RC-15	1:1	357	2.03	5,000	5
RC-15	2:1	151	0.87	5,000	5

* Torque @ 100 RPM and 750 hours of life.

Note: Drawings are artist's conception — not for certification; dimensions are subject to change without notice.

ACCESSORIES MITER GEAR BOXES

RC-18 THROUGH RC-204

Lubrication

Units shipped less lubricant.
Fill with EP-90 gear oil.

Model RC-18	1 pint
Model RC-38	1 1/2 pints
Model RC-99	4 1/2 pints
Model RC-204	8 pints

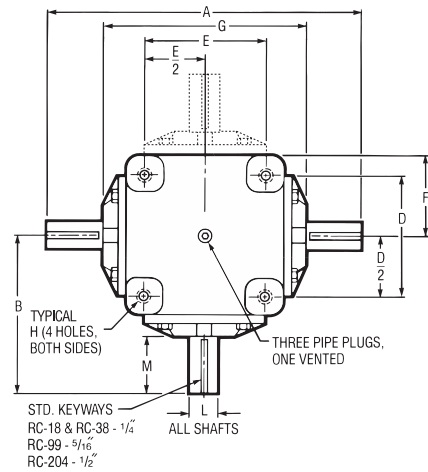
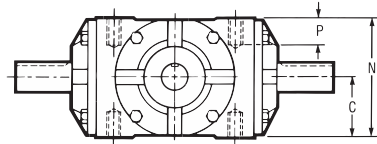

Model No.	Ratio	Max. Torque Rating (In. Lbs.)*	Max. HP @ 400 RPM	Max. RPM	A	B	C	D	E	F	G	H	L	M	N	P	Approx. Wt. (Lbs.)
RC-18	1:1	2154	10.78	3000	11	5 1/2	2 1/16	4 1/4	4 1/4	2 3/4	7	3/8 - 16	.9950 .9980	2	4 1/8	11/16	26
RC-18	2:1	569	3.24	5000	11	7 3/8	2 1/16	4 1/4	4 1/4	2 3/4	7	3/8 - 16	.9950 .9980	2	4 1/8	11/16	26
RC-38	1:1	4776	23.08	2200	13	6 1/2	2 13/16	4 1/2	4 1/2	2 7/8	8	1/2 - 13	1.2495 1.2480	2 1/2	5 5/8	7/8	39
RC-38	2:1	1211	6.85	4400	13	8 3/8	2 13/16	4 1/2	4 1/2	2 7/8	8	1/2 - 13	1.2495 1.2480	2 1/2	5 5/8	7/8	39
RC-99	1:1	13300	69.78	1600	16 1/2	8 1/4	3 3/4	6	6	4 1/8	10 5/8	1/2 - 13	1.3745 1.3730	2 15/16	7 1/2	1 3/8	72
RC-99	2:1	3446	19.24	3100	16 1/2	11 11/16	3 3/4	6	6	4 1/8	10 5/8	1/2 - 13	1.3745 1.3730	2 15/16	7 1/2	1 3/8	72
RC-204	1:1	29035	155.76	1200	19	9 1/2	4 3/4	8	8	4 15/16	13	5/8 - 11	1.9995 1.9980	3	9 1/2	1 1/4	172
RC-204	2:1	8156	45.05	2300	19	9 1/2	4 3/4	8	8	4 15/16	13	5/8 - 11	1.9995 1.9980	3	9 1/2	1 1/4	172

*Torque @ 100 RPM and 750 hours of life.

MKA

Lubrication

Units shipped less lubricant.
Fill with EP-90 gear oil.

Model MKA	1 1/4 pints
-----------	-------------

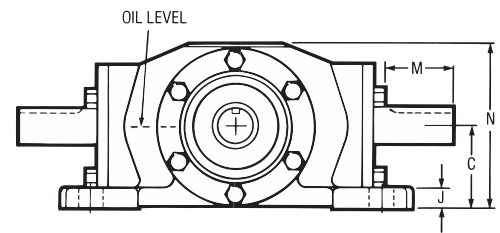
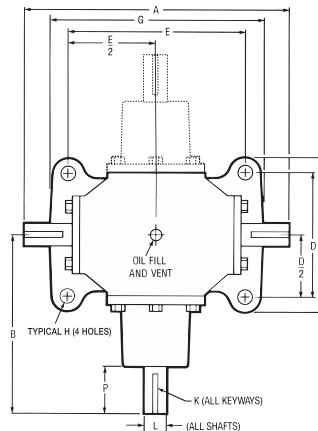

Model No.	Max. Torque Rating (In. Lbs.)	A	B	C	D	E	F	G	H	J	K	L	M	N	P	Approx. Wt. (Lbs.)
MKA	3,000	12	8	2 1/4	5 1/2	8	6 7/8	9 9/16	11/16	1/2	1/4 x 1/8 x 1 1/2	1.0005 .9995	1 31/32	4 9/16	2 1/8	33

Note: Drawings are artist's conception — not for certification; dimensions are subject to change without notice.

ACCESSORIES FLEXIBLE COUPLINGS

Joyce Model S and Model F geared couplings offer greater torque capacity than jaw couplings. With more gear teeth around the inner circumference of the coupling, plus high torsional, radial and angular stiffness mean that you get a more durable coupling.

Joyce Model S sleeve-type gear couplings are available in flex/rigid and flex/flex configurations.

Model F flange-type gear couplings offer superior radial-misalignment capability and radial flexibility.

Model J jaw-type couplings are ideal for many general industrial applications, require no lubrication and are resistant to oil, grease, moisture and other contaminants.

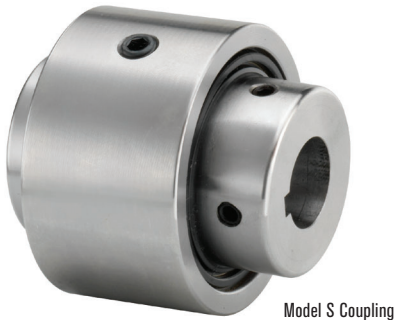

Specifying Information

When specifying hub sizes, please refer to the table to determine the three digit code. The first digit is the whole number of inches in shaft diameter, while the next two digits give the decimal equivalents of fractional inches.

1 63 = 1 5/8" dia. bore
 shaft shaft
 diameter diameter
 in inches decimal

Fraction	Dec. Code	Fraction	Dec. Code
0	00	1/2	50
1/16	06	9/16	56
1/8	13	5/8	63
3/16	19	11/16	69
1/4	25	3/4	75
5/16	31	13/16	81
3/8	38	7/8	88
7/16	44	15/16	94

Ordering Information — Order must indicate coupling size, coupling type (S = sleeve; F = flange; J = jaw), large diameter hub code, hub type (F = flex; R = rigid), small diameter hub code, hub type (F or R), and fit type (S = slip; I = interference).

Example: for sleeve and flange type

10	S	163	F	125	F	S
coupling size	coupling type	large diameter hub code	hub type	small diameter hub code	hub type	fit type

Example: for jaw type

09	J	100	88
coupling size	coupling type	large diameter hub code	small diameter hub code

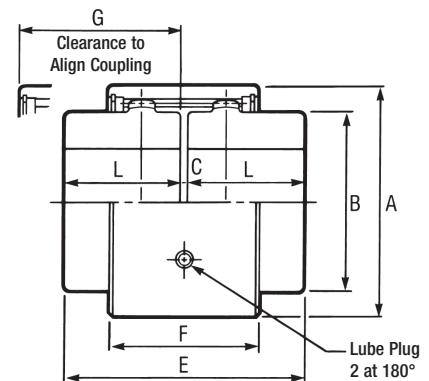

Model S Sleeve-Type																		
Size	Max. Bore (In.)	Load Capacity		Max. (RPM x 10 ³)	Parallel Offset Capacity (In.)	Lube Capacity			Dimension — Inch							Wt. Solid Hubs (Lbs.)	WR ² Solid Hubs (Lb. In. ²)	
		HP/100 (RPM)	Torque (In. Lbs. x 10 ³)			Grease		Oil Volume	A	B	L	C	E	F	G			
						Weight	Volume											
6S	1 1/16	4.5	2.84	19.0	.009	3/32 oz.	.006 pt.	.002 pt.	2 3/8	1 9/16	1 3/16	3/32	2 15/32	1 13/32	1 1/2	2.0	.86	
8S	1 5/16	7.0	4.41	16.0	.009	5/16 oz.	.019 pt.	.006 pt.	2 13/16	1 31/32	1 13/32	3/32	2 29/32	1 13/32	1 1/2	3.3	2.4	
10S	1 5/8	15.5	9.77	12.6	.015	11/32 oz.	.020 pt.	.006 pt.	3 9/16	2 3/8	1 9/16	3/32	3 7/32	1 27/32	1 7/8	6.1	8.1	
12S	1 15/16	22	13.9	11.5	.015	3/8 oz.	.022 pt.	.007 pt.	3 15/16	2 25/32	1 25/32	3/32	3 21/32	1 27/32	1 15/16	8.7	13.5	
15S	2	31	19.5	11.0	.039	7/8 oz.	1/16 pt.	1/64 pt.	4 1/8	2 15/16	1 15/16	1/8	4	2 25/32	2 29/32	11.5	21.1	
20S	2 5/8	51	32.1	8.8	.045	1 5/8 oz.	1/8 pt.	1/32 pt.	5 1/8	3 3/4	2 7/16	1/8	5	3 3/16	3 5/16	21.5	60.8	

1. Load capacities listed are the ratings based on full 1° misalignment per gear mesh.
2. Maximum bore listed are based on using a square key.
3. Speeds shown are without dynamic balancing.
4. Slip fit is standard.

Note: Drawings are artist's conception — not for certification; dimensions are subject to change without notice.

ACCESSORIES FLEXIBLE COUPLINGS



Model F Coupling

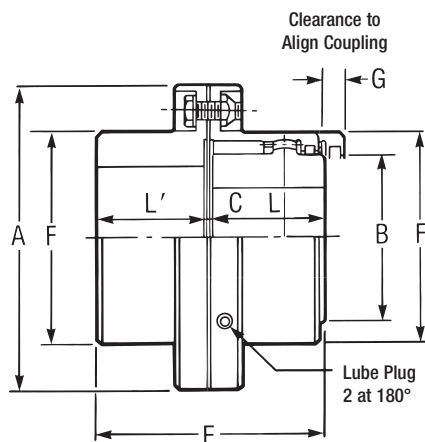

Model F Flange-Type

Size	Max. Bore (In.)		Load Capacity		Max. (RPM x 10 ³)	Lube Capacity			Dimension — Inch							Wt. Solid Hubs (Lbs.)	WR ² Solid Hubs (Lb. In. ²)	
	Flex. Half	Rigid Half	HP/100 (RPM)	Torque (In. Lbs. x 10 ³)		Grease		Oil Volume	A	B	L	L'	C	E	F			G
						Weight	Volume											
10F	1 5/8	2 1/8	15.5	9.77	6.5	.6 oz.	1/32 pt.	1/64 pt.	4 9/16	2 27/64	1 11/16	1 9/16	3/16	3 7/16	3 7/64	7/16	9.4	18.2
15F	2	2 3/4	31	19.5	5.3	1 1/8 oz.	1/16 pt.	1/32 pt.	6	2 15/16	1 15/16	1 27/32	5/32	3 15/16	3 29/32	13/32	18.8	66
20F	2 5/8	3 3/8	51	32.1	5.0	2 1/2 oz.	1/8 pt.	1/16 pt.	7	3 3/4	2 7/16	2 9/32	5/32	4 7/8	4 7/8	1/2	31.4	142

- Notes: 1. Load capacities listed are the ratings based on full 1° misalignment per gear mesh.
 2. Shrouded bolt designs are standard, but exposed will be furnished upon request.
 3. Maximum bore listed are based on using a square key.
 4. Speeds shown are without dynamic balancing.
 5. Slip fit is standard.

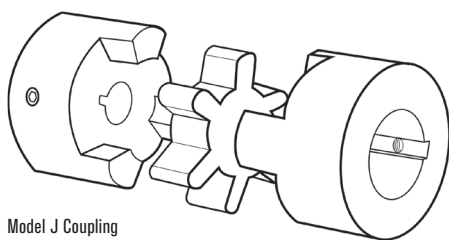

Model J Coupling

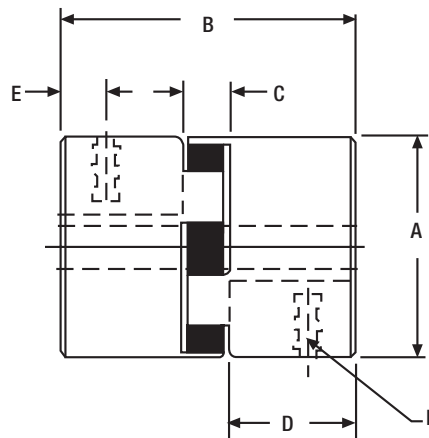

Model J Jaw-Type

Size	Max. Bore (In.)	Load Capacity Torque (In. Lbs.)	Dimension — Inch						Wt. Solid Hubs (Lbs.)	WR ² Solid Hubs (Lb. In. ²)
			A	B	C	D	E	F		
03J	.375	3.5	.62	.81	.27	.27	.13	#6-32	.1	.003
05J	.563	26.3	1.08	1.72	.48	.62	.31	1/4-20	.3	.054
07J	.750	43.2	1.36	2.00	.50	.75	.38	1/4-20	.6	.115
08J	.875	90.0	1.75	2.12	.50	.81	.31	1/4-20	1.0	.388
09J	1.000	144.0	2.11	2.12	.50	.81	.44	1/4-20	1.5	.772

Note: Torque values based on nitrile insert, other insert material available upon request.

Note: Drawings are artist's conception — not for certification; dimensions are subject to change without notice.

ACCESSORIES SHAFTING

Joyce shafting matches perfectly with Joyce jacks and couplings to meet a wide range of system requirements. Shafting is made from cold-finished 1018 steel, with ends machined to ANSI-standard keyways. For further information on common jack system arrangements, refer to page 190.

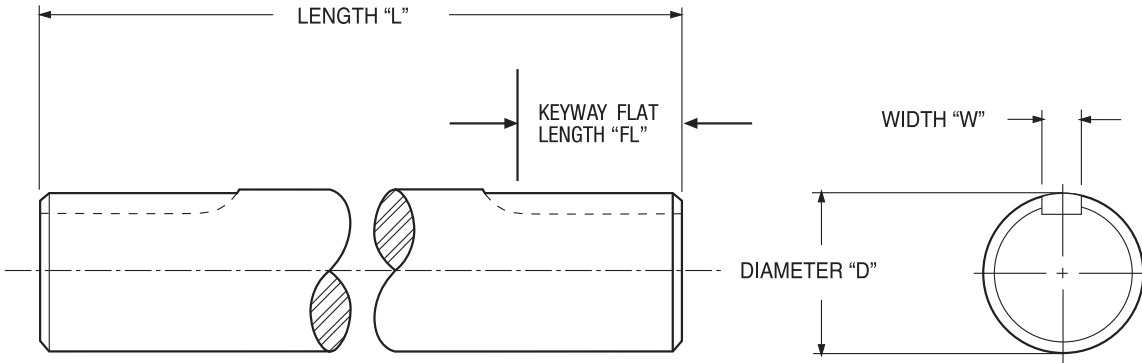

Dimensions and Minimum Shaft Length

Model	S50	S63	S75	S88	S100	S113	S125	S138	S150	S163	S175	S188	S200	S213	S225	S238	S250	S262	
Minimum Shaft Length* "L"	Flange	7	7	7	7	7	7	7	7	7	7	7	8	8	10	10	10	10	10
	Sleeve	5	5	5	5	5	6	6	6	7	7	7	8	8	10	10	10	10	10
Shaft Diameter "D" Inches	Nominal	1/2	5/8	3/4	7/8	1	1 1/8	1 1/4	1 3/8	1 1/2	1 5/8	1 3/4	1 7/8	2	2 1/8	2 1/4	2 3/8	2 1/2	2 5/8
	Actual	.500 .498	.625 .623	.750 .748	.875 .873	1.000 .998	1.125 1.123	1.250 1.248	1.375 1.373	1.500 1.498	1.625 1.623	1.750 1.748	1.875 1.872	2.000 1.997	2.125 2.122	2.250 2.247	2.375 2.372	2.500 2.497	2.625 2.621
Keyway Width "W"	1/8	3/16	3/16	3/16	1/4	1/4	1/4	5/16	3/8	3/8	3/8	1/2	1/2	1/2	5/8	5/8	5/8	5/8	5/8
Keyway Flat Length "FL"	1.25	1.25	1.25	1.25	1.25	1.5	1.5	1.75	1.75	1.75	2	2	2	2.5	2.5	2.5	2.5	2.5	2.5

*These are the minimum shaft lengths that can be ordered when Joyce Model "S" sleeve type couplings or "F" flange-type couplings are selected. See pages 184 and 185 for coupling information.

Note: Drawings are artist's conception — not for certification; dimensions are subject to change without notice.

ACCESSORIES SHAFTING

To use this chart, follow these steps:

1. Find a "Shaft Torque" value in the far left column that is greater than, or equal to, your calculated torque value.
2. Move to the second column to find your "Nominal Shaft Diameter" (round up to arrive at an offered shaft size).
3. The third column shows the maximum allowable shaft span before supports (pillow blocks) are required.
4. Compare your actual shaft speed (RPM) with the maximum allowable speed (RPM) for the shaft you have chosen. If you are above the allowable shaft speed, then increase the shaft size until it falls into the allowable range.

Diameter Selection Chart			Maximum Allowable RPMs***										
Shaft Torque (Inch/Lbs.)	Nominal Shaft Diameter* (Inches)	Maximum** Distance Between Supports (Inches)	Shaft Lengths (Inches)										
			36	48	60	72	84	96	108	120	132	144	156
20	0.51	54.6	1802	1014	649	450	331	253	200	162	134	113	96
40	0.73	61.3	2143	1205	771	536	394	301	238	193	159	134	114
50	0.81	65.5	2372	1334	854	593	436	333	264	213	176	148	126
80	0.87	68.8	2548	1433	917	637	468	358	283	229	190	159	136
100	0.92	71.4	2695	1516	970	674	495	379	299	243	200	168	143
150	1.01	76.3	2982	1677	1074	746	548	419	331	268	222	186	159
200	1.09	80.1	3204	1802	1154	801	589	451	356	288	238	200	171
250	1.15	83.1	3388	1906	1220	847	622	476	376	305	252	212	180
300	1.21	85.7	3546	1995	1277	887	651	499	394	319	264	222	189
350	1.25	87.9	3686	2073	1327	921	677	518	410	332	274	230	196
400	1.30	89.9	3811	2144	1372	953	700	536	423	343	283	238	203
450	1.34	91.7	3925	2208	1413	981	721	552	436	353	292	245	209
500	1.37	93.3	4029	2266	1451	1007	740	567	448	363	300	252	215
600	1.44	96.2	4217	2372	1518	1054	775	593	469	380	314	264	225
700	1.49	98.7	4383	2465	1578	1096	805	616	487	394	326	274	233
800	1.54	100.9	4532	2549	1631	1133	832	637	504	408	337	283	241
900	1.59	102.9	4667	2625	1680	1167	857	656	519	420	347	292	249
1000	1.63	104.7	4792	2695	1725	1198	880	674	532	431	356	299	255
1250	1.72	108.7	5067	2250	1824	1267	931	712	563	456	377	317	270
1500	1.80	112.0	5303	2983	1909	1326	974	746	589	477	394	331	282
1750	1.92	114.9	5511	3100	1984	1378	1012	775	612	496	410	344	293
2000	1.94	117.5	5698	3205	2051	1425	1047	801	633	513	424	356	303
2250	2.00	119.8	5869	3301	2113	1467	1078	825	652	528	437	367	313
2500	2.05	122.0	6025	3389	2169	1506	1107	847	669	542	448	377	321
3000	2.15	125.7	6306	3547	2270	1577	1158	887	701	568	469	394	336
3250	2.19	127.4	6434	3619	2316	1608	1182	905	715	579	479	402	343
3500	2.23	129.0	6554	3687	2359	1639	1204	922	728	590	487	410	349
4000	2.31	131.9	6776	3812	2440	1694	1245	953	753	610	504	424	361
4500	2.38	134.5	6979	3926	2512	1745	1282	981	775	628	519	436	372
5000	2.44	136.9	7165	4030	2579	1791	1315	1008	796	645	533	448	382
6000	2.55	141.1	7499	4218	2700	1875	1377	1055	833	675	558	469	399
7000	2.65	144.8	7794	4384	2806	1949	1432	1096	866	701	580	487	415

Note: Shaded area exceeds maximum distance between supports. Pillow blocks are required.

*Shaft diameter is based on 0.08 degrees twist per foot of length.

**Maximum distance between supports is based on a maximum allowable deflection of 0.01 inches per foot of length.

***Maximum allowable RPMs is based on 80% of critical shaft speed.

Length Specifying Information

Joyce shafts can be ordered in 1/16 inch increments of length. When specifying shaft length, please refer to the table below to determine the decimal code for fractions of length.

Fraction	0	1/16	1/8	3/16	1/4	5/16	3/8	7/16	1/2	9/16	5/8	11/16	3/4	13/16	7/8	15/16
Decimal	.00	.06	.13	.19	.25	.31	.38	.44	.5	.56	.63	.69	.75	.81	.88	.94

Ordering Information

- Example: A. For a 1/2" dia. x 33 3/8" long Part Number = **S50-33.38**
 B. For a 1 1/4" dia. x 110" long Part Number = **S125-110.00**
 C. For a 2 1/4" dia. x 58 7/16" long Part Number = **S225-58.44**

Note: Drawings are artist's conception — not for certification; dimensions are subject to change without notice.

CONTROLS MOTOR STARTERS

Joyce motor starters are the heart of a basic control system for a motorized jack, actuator, electric cylinder, or ComDRIVE® system. Motor starters include extend and retract push buttons for momentary operation; an illuminated power-on light lets operators easily determine if there is power to the system.

Other standard features:

- Limit switch terminals for two LS8-402 end-of-travel limits
- 1/3 - 15 HP motors standard
- 208, 230, 460, and 575 volts standard, three-phase power requirements
- NEMA 4 enclosure
- All three-phase motor starters include IEC motor overload protection

Ordering information:

Each model's part number begins with the prefix 07990377. To this prefix, add the appropriate suffix from the chart below. For example: 07990377-17 refers to a motor starter for a 1 1/2 horsepower, 208 volt motor.

Motor HP Starter Part Number Suffix				
Motor HP	Voltage			
	208	230	460	575
1/3	-1	-2	-3	-4
1/2	-5	-6	-7	-8
3/4	-9	-10	-11	-12
1	-13	-14	-15	-16
1 1/2	-17	-18	-19	-20
2	-21	-22	-23	-24
3	-25	-26	-27	-28
5	-29	-30	-31	-32
7 1/2	-33	-34	-35	-36
10	-37	-38	-39	-40
15	-41	-42	-43	-44

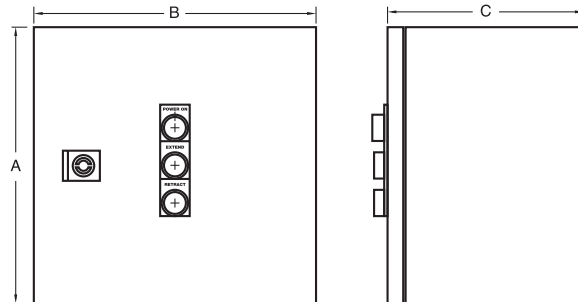

Many options are available including:

- NEMA 4X enclosure
- 50 Hz motors
- International voltages
- Single-phase motors
- Multiple starters in a single enclosure
- Starters for larger horsepower motors
- Explosion-proof enclosure
- Maintained contact control
- Stack lights
- Audible alarm
- Wiring for LS7 and LS8-404 and other limits

Note: Drawings are artist's conception — not for certification; dimensions are subject to change without notice.

CONTROLS VARIABLE SPEED POSITIONING SYSTEM

Joyce Variable Speed Positioning System (VSPS) is a programmable controller that increases the capability of motorized jacks by allowing the operator to easily program up to ten stopping positions.

It is housed in two NEMA 4 enclosures, one for the VFD the other for the PLC (as shown). The VSPS includes an HMI display that indicates the current position as well as the stopping location.

Other standard features:

- Limit switch terminals for two LS8-402 end-of-travel limits
- Speed control dial (real time)
- Emergency stop push button
- 1/3 – 3 HP motor control standard
- 208, 230, 460 and 575 volts standard, three-phase power requirements
- 3" HMI display
- Manual jog

Ordering information:

Each model's part number begins with the prefix 07990951. To this prefix add the appropriate suffix from the chart below. For example: 07990951-2 refers to a VSPS control for a 1/3 horsepower, 230 volt motor.

Motor HP Starter Part Number Suffix			
Motor HP	Voltage		
	208	230	460
1/3	-1	-2	-3
1/2	-5	-6	-7
3/4	-9	-10	-11
1	-13	-14	-15
1 1/2	-17	-18	-19
2	-21	-22	-23
3	-25	-26	-27

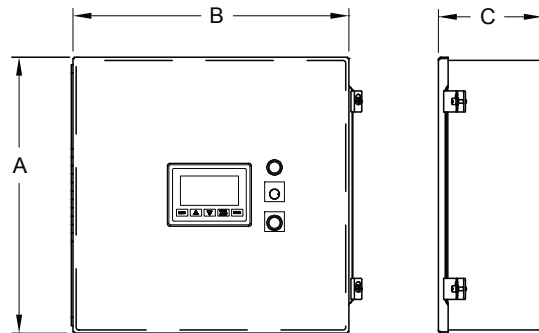

Many options are available including:

- NEMA 4X enclosure
- 50 Hz motors
- International voltages
- Single-phase motors
- 5 horsepower and larger
- Pendant controls
- Maintained contact control
- Stack lights
- Audible alarm
- Wiring for LS7 and LS8-404 and other limits

Note: Drawings are artist's conception — not for certification; dimensions are subject to change without notice.

COMMON SYSTEM ARRANGEMENTS

Joyce jacks, miter gear boxes, couplings and motorized ComDRIVEs® can be used in a number of system arrangements. Several are shown here.

Because jacks selected for systems have uniform lifting speeds and are fully synchronized, unevenly distributed loads can be raised, lowered, and positioned in unison. Jacks of differing capacities may be used in the same system as long as driven shafts turns per 1" of travel are the same.

Arrows indicate the rotational direction to raise the load.

Wormgear I System Features ComDRIVE®

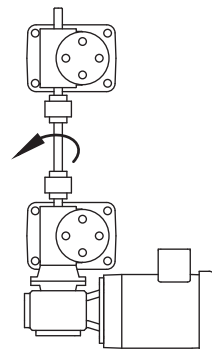

Wormgear U System

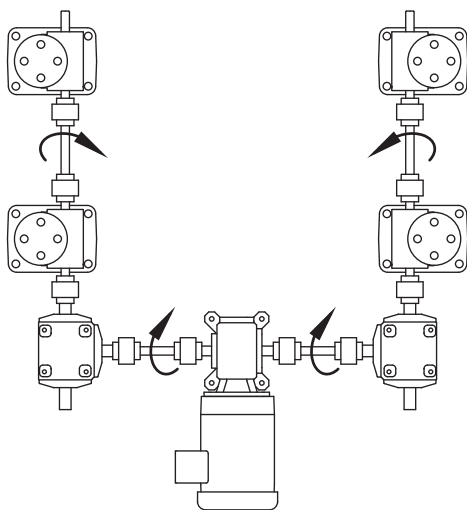

Wormgear T System

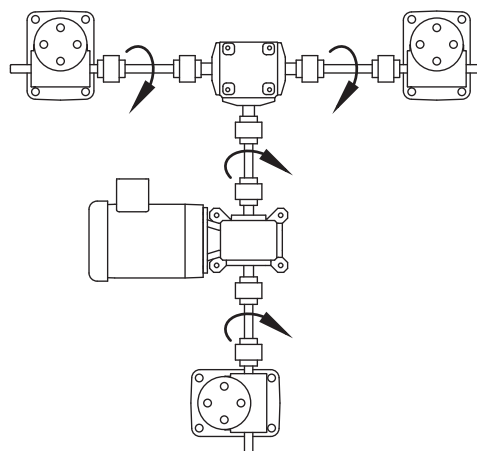

Wormgear H System

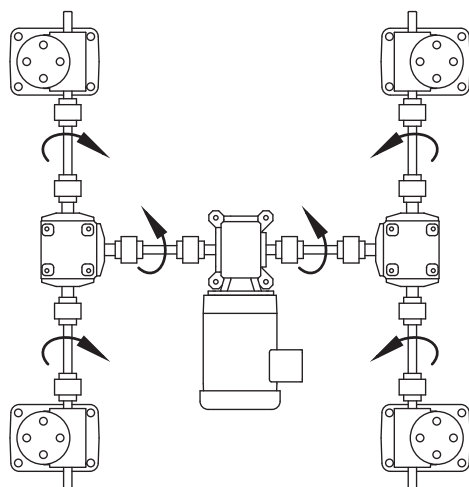

Bevel Gear U System

