

METRIC SCREW JACKS

Joyce offers Metric Screw Jacks in several designs including:

- Translating
- Keyed for non-rotation
- Keyed for traveling nut (KFTN)
- Double clevis

A guide for ordering is on pages 72 and 73.

Joyce metric screw jacks, series MWJ, are specifically designed for positioning and lifting applications that must be fully metric. These jacks are commonly used in OEM machinery manufactured in the U.S. and shipped to other countries around the world. They are fully interchangeable with several European products.

Metric screw jacks are available in four capacities: 10 kN, 25 kN, 50 kN, and 100 kN. MWJ screw jacks feature:

- Industry standard metric (trapezoidal) lifting screw diameters and pitches.
- Fully metric mounting hole locations, diameters and fasteners.
- Alloy steel worm shafts and bronze wormgears and traveling nuts.
- Tapered roller or ball thrust bearings provide rugged reliability.

Both upright and inverted configurations of these precision jacks operate at full capacity whether the load is in tension or compression. All MWJ jacks are self-locking under full capacity.

Metric screw jacks are available with one of four standard screw ends or special ends to meet your requirements. Double input shafts are standard. An optional anti-backlash feature (page 181) compensates for thread wear, assuring minimum play between lifting screw and wormgear for smooth, precise operation. All jack designs can be fitted with protective boots.

Joyce can customize metric screw jacks to meet your specifications.



Scan the QR Code to view this product on our website.

METRIC SCREW JACKS ORDERING INFORMATION

Instructions: Select a model number from this chart.

10 kN	25 kN	50 kN	100 kN
MWJ51 MWJ201	MWJ62.5 MWJ122.5 MWJ242.5	MWJ65 MWJ125 MWJ245	MWJ810 MWJ2410

Sample Part Number: **MWJ65U2S-300-STD_X-STD_X-B**

Jack Configuration

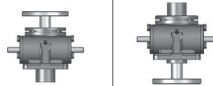

U=Upright **I=Inverted**

End Conditions



1=T1
(plain end)

2=T2
(load pad)

3=T3
(threaded end)

4=T4
(male clevis)

Left Side Shaft Code
(see below)

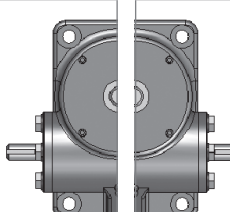

XXXX=Remove
STD_X=Standard
CUST=Custom

For optional shaft codes, see page 73.

Right Side Shaft Code
(see below)

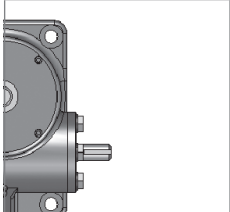

XXXX=Remove
STD_X=Standard
CUST=Custom

For optional shaft codes, see page 73.

Additional Options*

X=Standard Jack, no additional options

S=Additional Specification Required (comment as necessary)

Anti-Backlash
p. 177
A=Split Nut
A90=A90 Design
A95=A95 Design

Protective Boots
pp. 166-168
B=Protective Boot
D=Dual Protective Boot

Finishes p. 178
F1=Do Not Paint
F2=Epoxy Paint
F3=Outdoor Paint Process

Motor Options
M1=Less Motor
M2=Brake Motor
M3=Single Phase Motor (120VAC)
M4=50Hz Motor
M5=Special Motor

Grease/Seals
H1=High Temperature Operation
H2=Food Grade

Screw Stops
ST0=Extending
ST1=Retracting
ST2=Both

* Specify as many options as needed

Metric Screw Jack Rise

Rise is travel expressed in millimeters and not the actual screw length.

Jack Designs



S=Translating **K=Keyed for Non Rotation** **N=Traveling Nut** **D=Double Clevis*** **A=KFTN Trunnion***
T=Trunnion*

*Contact Joyce with your requirements.

METRIC SCREW JACKS SHAFT CODES

Instructions: Select the appropriate shaft codes for both right and left hand shafts. One shaft code must be specified for each side of the jack.

Screw Stops (p. 10) and Boots (pp. 166-168)

Screw stops are optional on metric screw jacks. When specified, the closed height of the jack and the protection tube length may be increased.

When boots are added to metric jacks, the closed height of the jack may be increased.

Mechanical Counters (p. 176)

CNT0=0.025 mm increments

Note: Contact Joyce for availability and options.



Hand Wheels (p. 176)

HW04=4" dia.(102mm)
HW06=6" dia.(152mm)
HW08=8" dia.(203mm)
HW10=10" dia.(254mm)
HW12=12" dia.(305mm)

Recommended for self-locking jacks only.



Geared Potentiometers (p. 171)

POTA=0-10V
POTB=4-20mA
POTC=0-10V w/2 switches
POTD=4-20mA w/2 switches

IP65 rated enclosures



Encoders (pp. 172-173)

ENCA=Absolute Encoder 0-10 VDC, programmable
ENCB=Absolute Encoder 4-20mA, programmable
ENCC=Absolute Encoder CAN Open
ENCD=Absolute Encoder SSI
ENCS=Stainless Steel Incremental Encoder 1024 PPR
ENCX=Incremental Encoder 200 PPR
ENCY=Incremental Encoder 1024 PPR



Motors for Systems and Direct Drives (pp. 178-179)

- All standard motors are 3-phase, 208-230/460 VAC or 230/460 VAC. Other motor options are available. Specify the appropriate motor size from the chart on the right.
- Refer to the "Additional Options" chart on the preceding page as needed.
- If the motor frequency will be varied to provide a "soft" start, an inverter duty motor may be required.
- International voltage motors are available.

Motors

Size	Code
1/4 HP	K
1/3 HP	A
1/2 HP	B
3/4 HP	C
1 HP	D
1-1/2 HP	E
2 HP	F
3 HP	L
5 HP	G

Motor Mounts (pp. 178-179)

Ordering Example:

MMA A





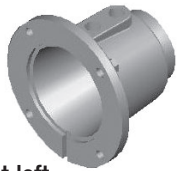



















MMA=56C Motor code from chart at left
MMB=140TC For servo motor mounts see p. 174
MMC=180TC
MMD=210TC

- Standard motor adapters are aluminum.
- Motor adapters for many IEC motors are available as an option.



Mechanical Limit Switches (p. 170)

Ordering Example: **LA13**

Models		Number of DPDT Switches (see p. 170)	Available Positions							
Model	Code		1	2*	3	4*	5	6*	7*	8*
LS7-402	LI	NOTE: Will always be 0 for LS7 models								
LS8-402	LA									
LS8-404	LB									

*25 kN, 50 kN, and 100 kN metric jacks are available with positions #1, #3, and #5.
 *These positions are not standard. Contact Joyce with your requirements.

METRIC SCREW JACKS COLUMN LOADING

Metric Screw Jacks Column Loading Chart

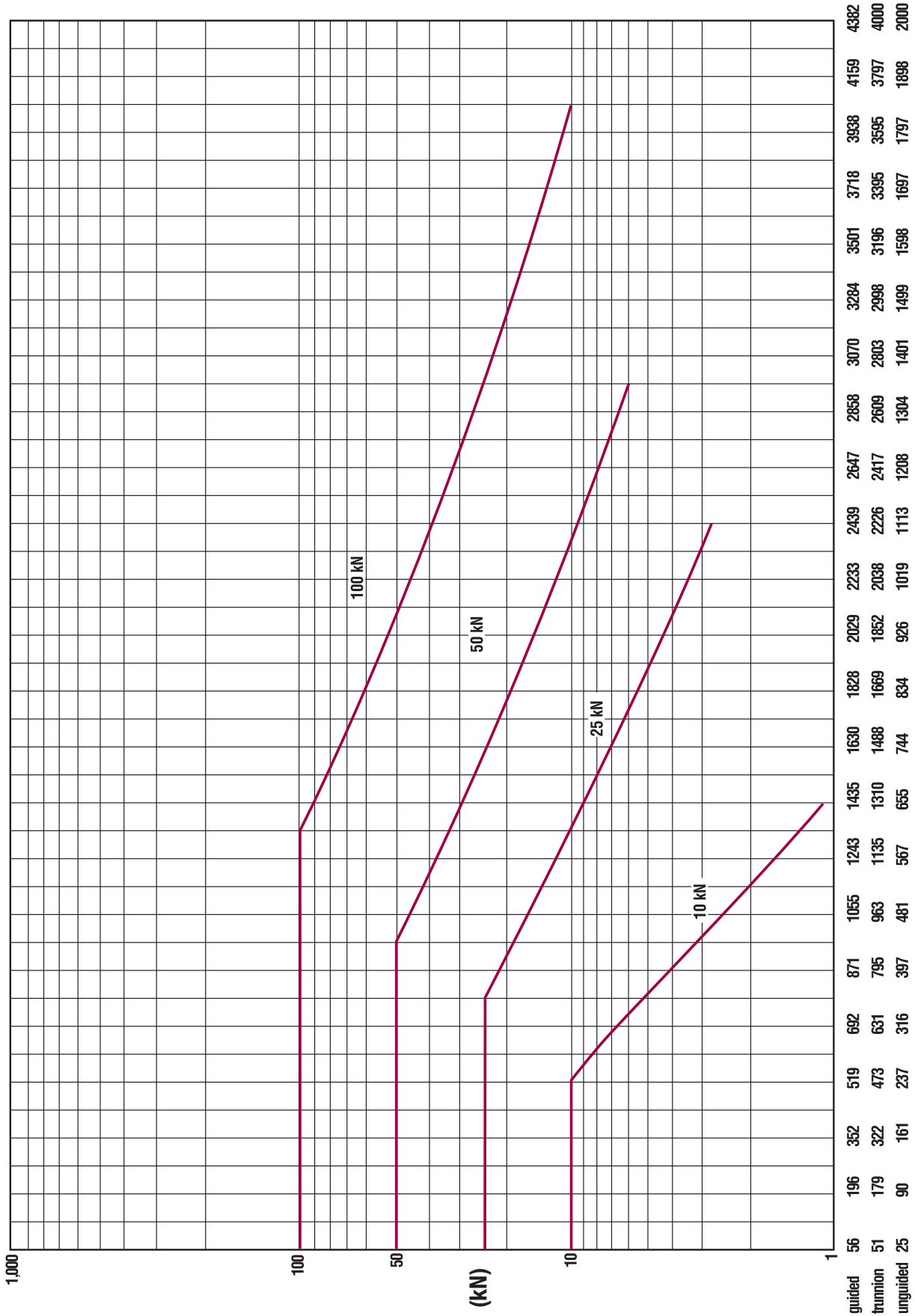

Screw Length (mm)

This chart includes a 2:1 Factor-of-Safety based on the Euler-Johnson equation for column loading. The horizontal portion of each line represents the jack's maximum static capacity. Under static conditions, these lines can be exceeded. Please contact the factory for assistance.

METRIC SCREW JACKS SPECIFICATIONS

Model	Capacity	Screw Diameter (mm)	Thread Pitch/Lead	Worm Gear Ratio	Worm Shaft Turns for 1mm Travel	Tare Torque (Nm)	Starting Torque (Nm)	Operating Torque (Nm)	Efficiency Rating % Approx.	Screw Torque (Nm)	Basic Jack Weight (Kg)	Screw Weight (Kg) per 25mm Travel
MWJ51	10kN	20	5mm	5:1	1	0.33	.95W*	.70W* @ 500 RPM	22.7	2W*	2.7	0.14
MWJ201				20:1	4		.41W*	.23W* @ 500 RPM	17.0			
MWJ62.5	25kN	30	6mm	6:1	1	0.67	1.01W*	.81W* @ 500 RPM	19.6	3W*	6.8	0.18
MWJ122.5				12:1	2		.62W*	.45W* @ 500 RPM	17.8			
MWJ242.5				24:1	4		.44W*	.27W* @ 500 RPM	14.7			
MWJ65	50kN	40	9mm	6:1	0.67	1.13	1.64W*	1.14W* @ 300 RPM	20.9	4W*	14.5	0.32
MWJ125				12:1	1.33		1.03W*	.64W* @ 300 RPM	18.7			
MWJ245				24:1	2.67		.74W*	.39W* @ 300 RPM	15.2			
MWJ810	100kN	55	12mm	8:1	0.67	2.26	1.53W*	1.18W* @ 200 RPM	20.2	5W*	19.5	0.59
MWJ2410				24:1	2		.76W*	.49W* @ 200 RPM	16.1			

*W: Load in kN.

Tare Torque: Initial torque to overcome seal and normal assembly drag. This value must be added to starting torque or operating torque values.

Starting Torque: Torque value required to start moving a given load (dissipates to operating torque values once the load begins moving).

Operating Torque: Torque required to continuously raise a given load at the input RPM listed.

Screw Torque: Torque required to resist screw rotation (Translating Design Jacks) and traveling nut rotation (Keyed for Traveling Nut Design Jacks).

Lead: The distance traveled axially in one rotation of the lifting screw.

Pitch: The distance from a point on a screw thread to a corresponding point on the next thread measured axially.

Note: This chart is provided for reference only. For specific information such as column loading allowable continuous travel and other performance factors please contact Joyce/Dayton.

METRIC SCREW JACKS

10kN - 20mm SCREW

MWJ 51
MWJ 201

Upright

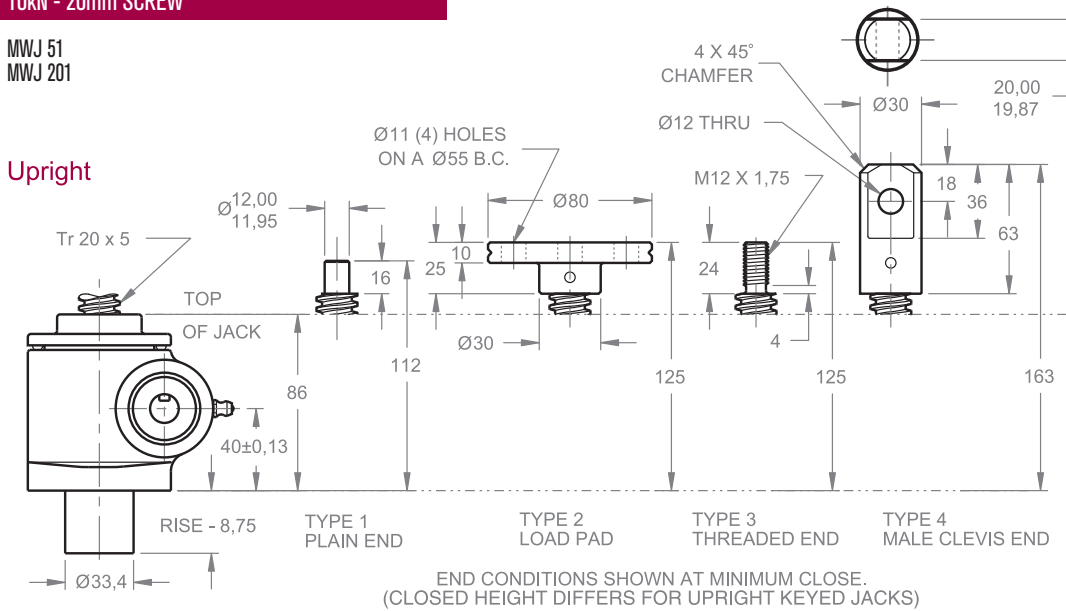

Upright keyed

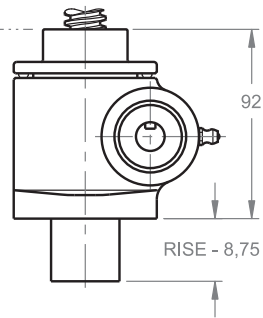

Upright traveling nut

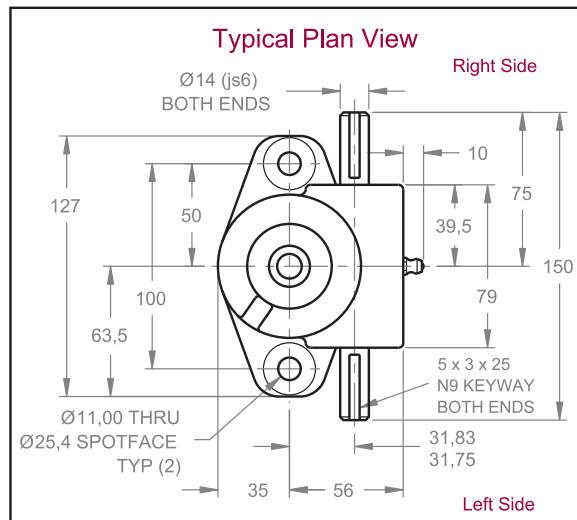
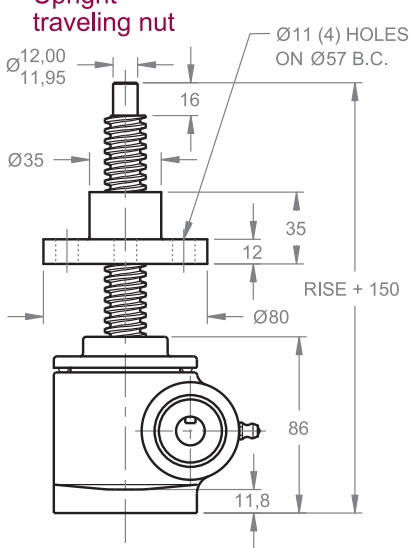

Inverted traveling nut

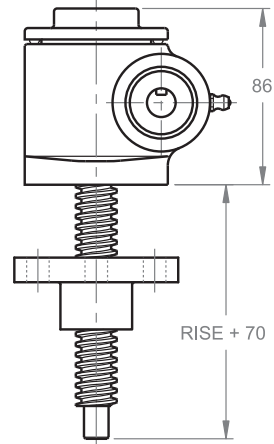

Inverted

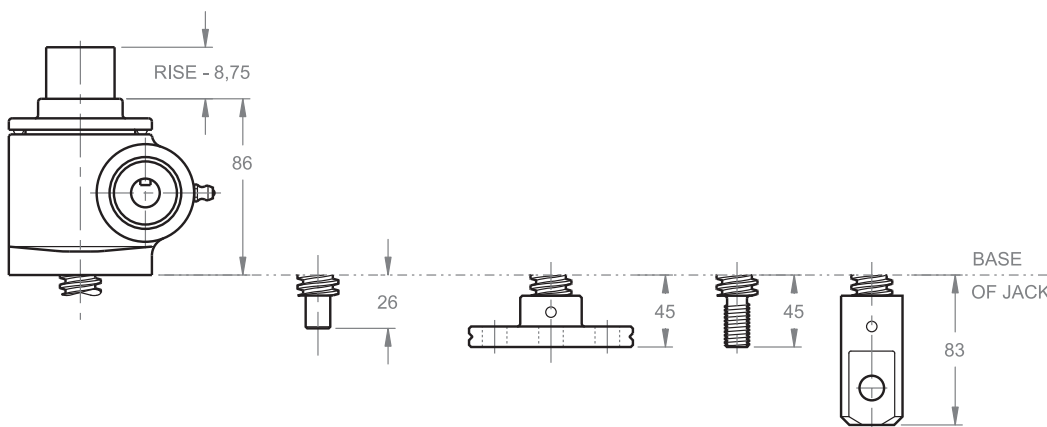

Inverted keyed

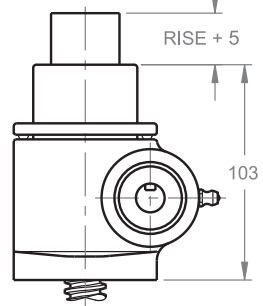

Note: Drawings are artist's conception — not for certification; dimensions are subject to change without notice.

METRIC SCREW JACKS

25kN - 30mm SCREW

MWJ 62.5
MWJ 122.5
MWJ 242.5

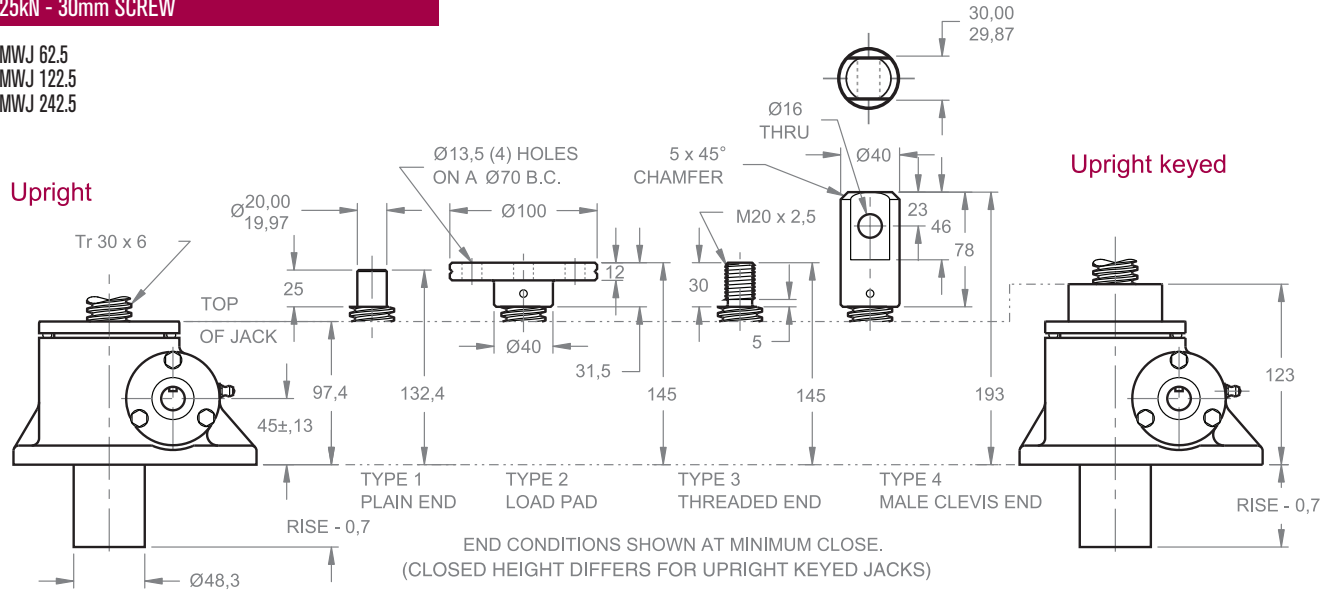

Upright traveling nut

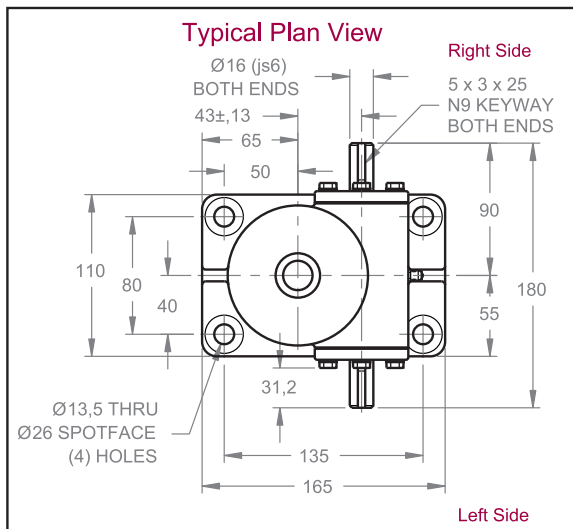
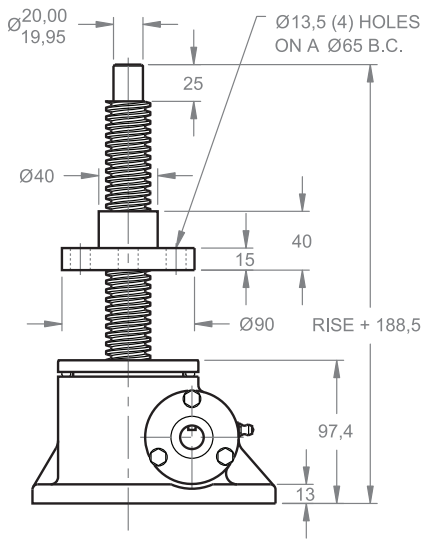

Inverted traveling nut

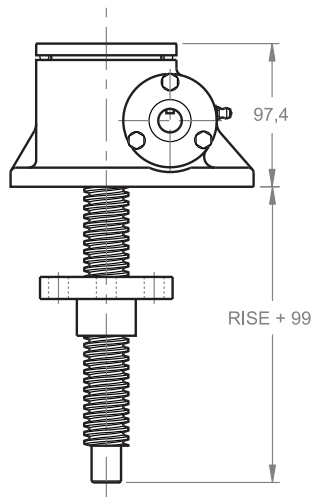

Inverted

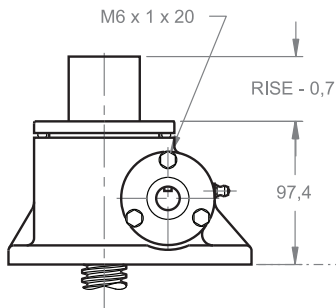

Inverted keyed

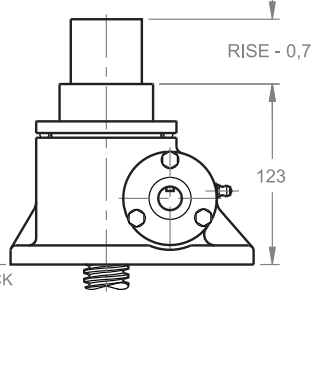

Note: Drawings are artist's conception — not for certification; dimensions are subject to change without notice.

METRIC SCREW JACKS

50kN - 40mm SCREW

MWJ 65
MWJ 125
MWJ 245

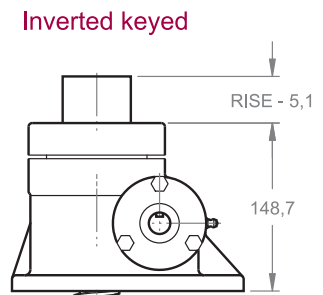
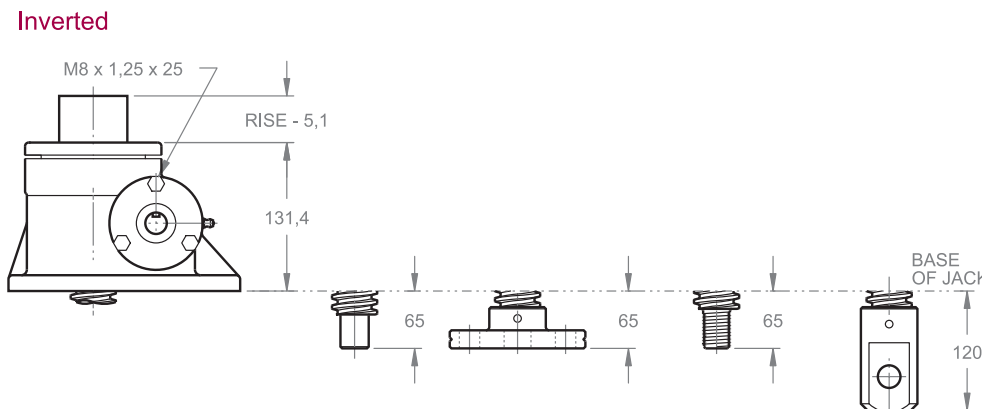
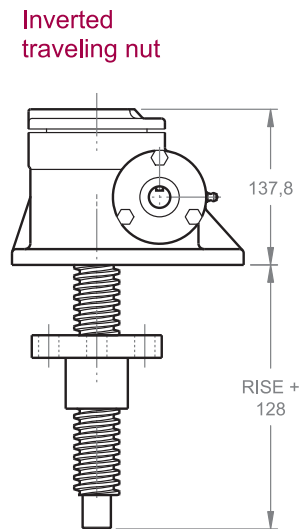
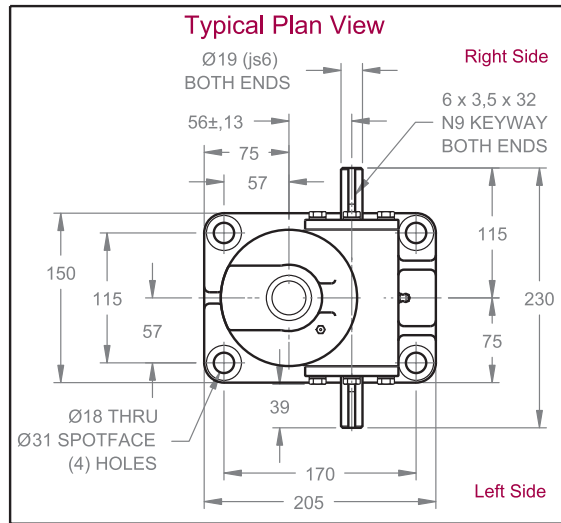
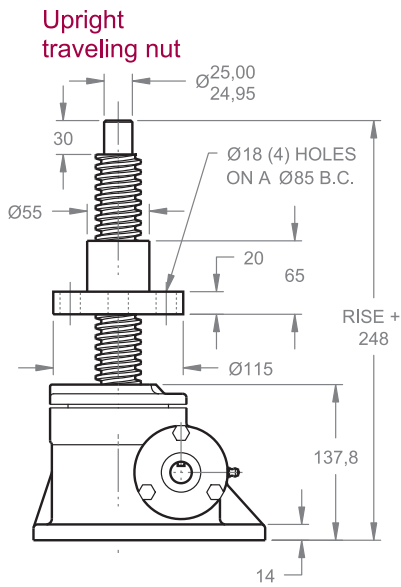
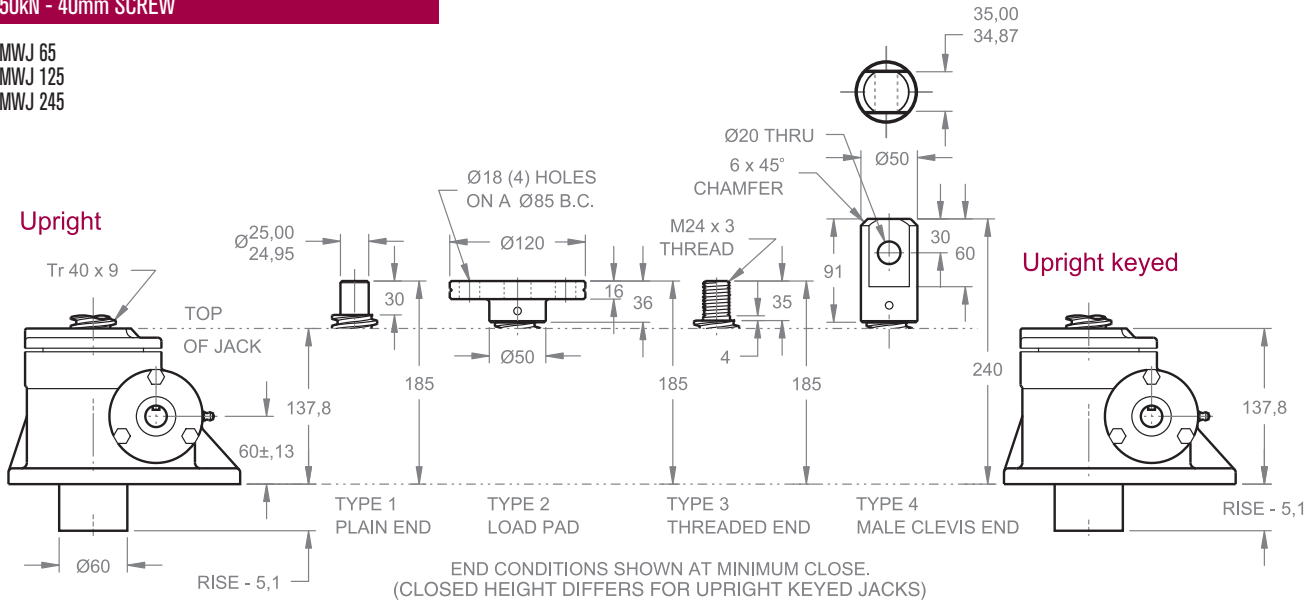

Note: Drawings are artist's conception — not for certification; dimensions are subject to change without notice.

METRIC SCREW JACKS

100kN - 55mm SCREW

MWJ 810
MWJ 2410

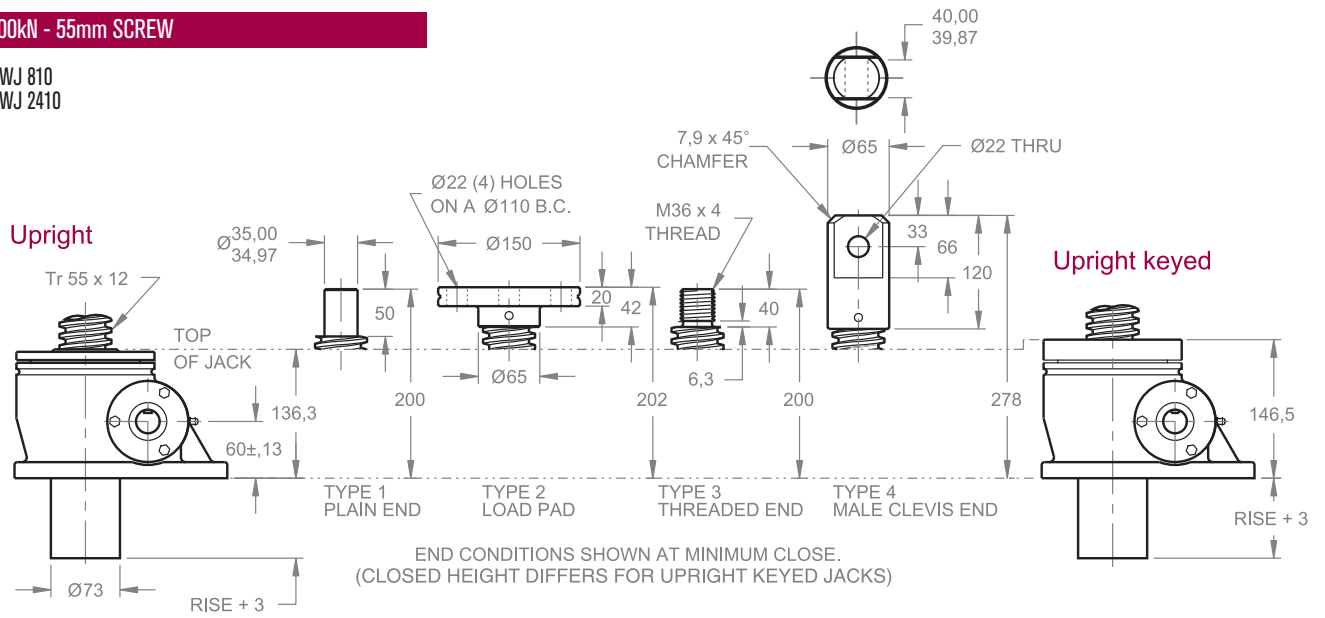

Upright traveling nut

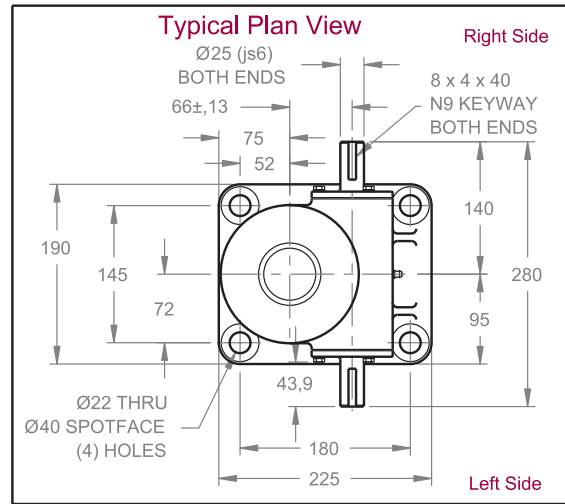
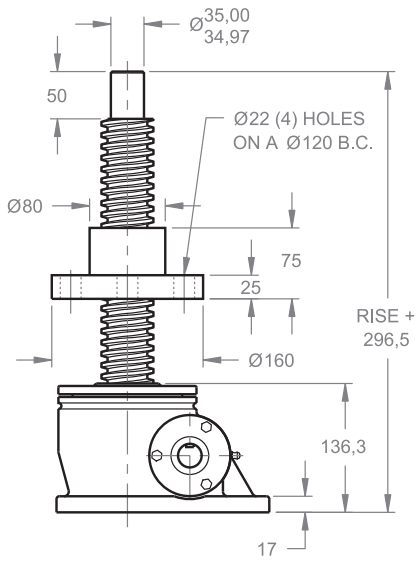

Inverted traveling nut

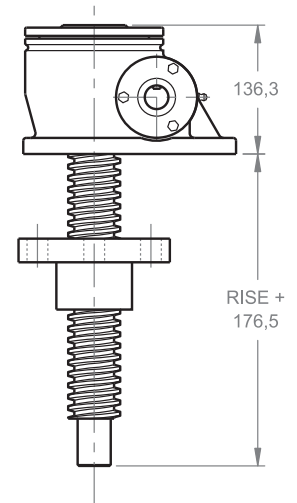

Inverted

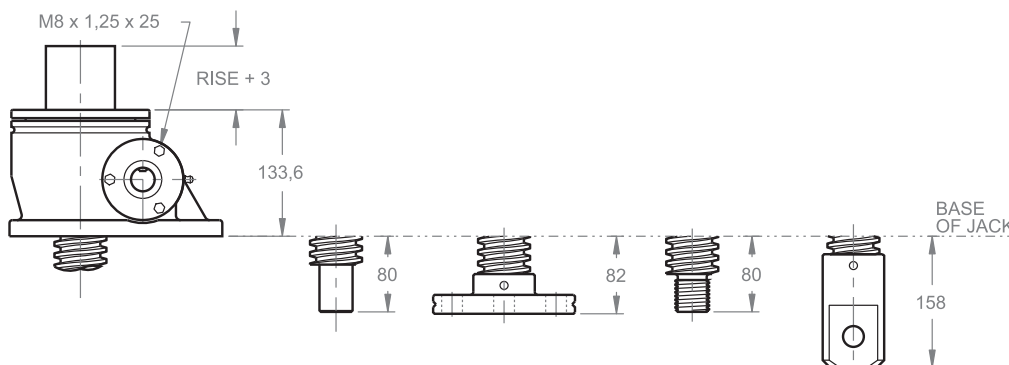

Inverted keyed

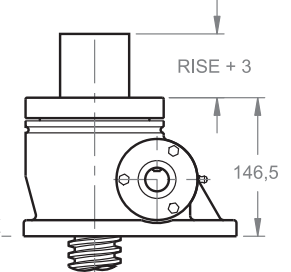

Note: Drawings are artist's conception — not for certification; dimensions are subject to change without notice.