

# TABLE OF CONTENTS

<b>Engineering Information</b>	
Jack Cutaway Illustrations.....	4
Quick Reference Guide.....	6
Options Overview.....	7
Selection Guide Worksheet – Jacks and Actuators.....	8
Selection Guide Worksheet – Controls.....	9
Product Selection Factors.....	10
Column Load Factors.....	11
Jack Designs.....	12
Torque and Horsepower.....	13
Options, Accessories and Controls.....	14
FAQ.....	16
<b>Machine Screw Jacks.....</b>	<b>18</b>
Ordering Information.....	20
<b>Machine Screw ComDRIVES®.....</b>	<b>45</b>
Ordering Information.....	46
<b>Stainless Steel Screw Jacks.....</b>	<b>58</b>
Ordering Information.....	60
<b>Metric Screw Jacks.....</b>	<b>71</b>
Ordering Information.....	72
<b>Ball Screw Jacks.....</b>	<b>80</b>
Ordering Information.....	82
<b>Ball Screw ComDRIVES.....</b>	<b>102</b>
Ordering Information.....	104
<b>Electric Cylinders.....</b>	<b>118</b>
Ordering Information.....	120
<b>Integrated Actuators.....</b>	<b>135</b>
Ordering Information.....	137
<b>Bevel Gear® Jacks.....</b>	<b>144</b>
Ordering Information.....	146
<b>Bevel Ball Actuators.....</b>	<b>155</b>
Ordering Information.....	156
<b>Options, Accessories and Controls.....</b>	<b>164</b>
Boots for Machine Screw Jacks.....	166
Boots for Ball Screw Jacks.....	167
Boots for KFTN Jacks.....	168
Limit Switches.....	170
Geared Potentiometers.....	171
Encoders.....	172
Servo Motor Mounts.....	174
Motor Mounts and Stock Motors.....	175
Hand Wheels and Counters.....	176
Anti-Backlash Designs.....	177
Finishes.....	178
Trunnion Mounts.....	179
Pillow Blocks and Flange Blocks.....	180
Miter Gear Boxes.....	181
Couplings.....	184
Shafting.....	186
Motor Controls.....	188
Common System Arrangements.....	190

ENGINEERING INFORMATION
MACHINE SCREW JACKS
MACHINE SCREW ComDRIVES®
STAINLESS STEEL SCREW JACKS
METRIC SCREW JACKS
BALL SCREW JACKS
BALL SCREW ComDRIVES®
ELECTRIC CYLINDERS
INTEGRATED ACTUATORS
BEVEL GEAR® JACKS
BEVEL BALL ACTUATORS
OPTIONS, ACCESSORIES AND CONTROLS

# WORMGEAR STYLE JACK UPRIGHT TRANSLATING STYLE SHOWN

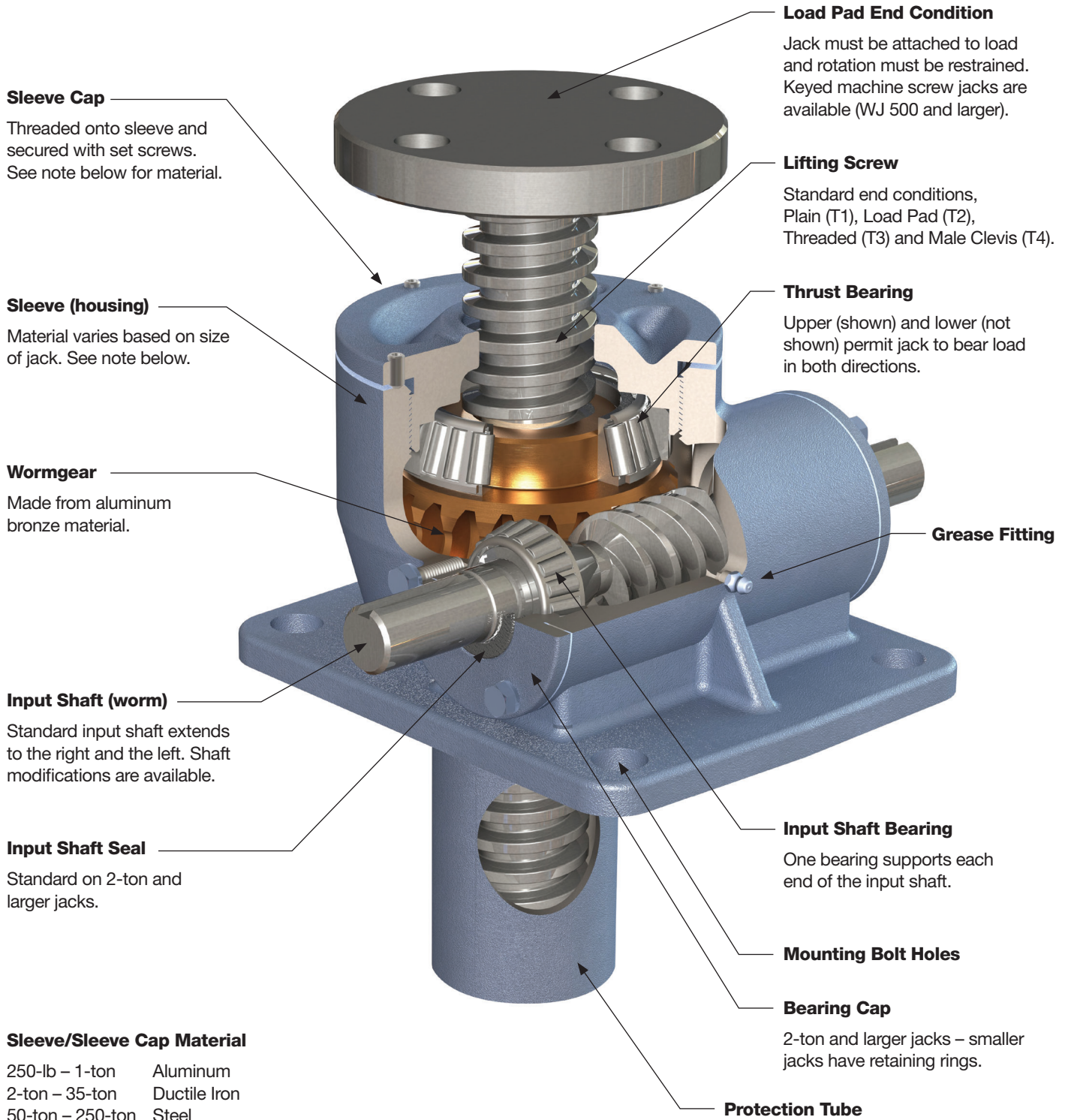

## Sleeve/Sleeve Cap Material

250-lb – 1-ton	Aluminum
2-ton – 35-ton	Ductile Iron
50-ton – 250-ton	Steel

## Options

2-ton	Stainless Steel
5-ton – 25-ton	Stainless Steel
5-ton – 35-ton	Steel

# BEVEL GEAR STYLE JACK UPRIGHT TRANSLATING STYLE SHOWN

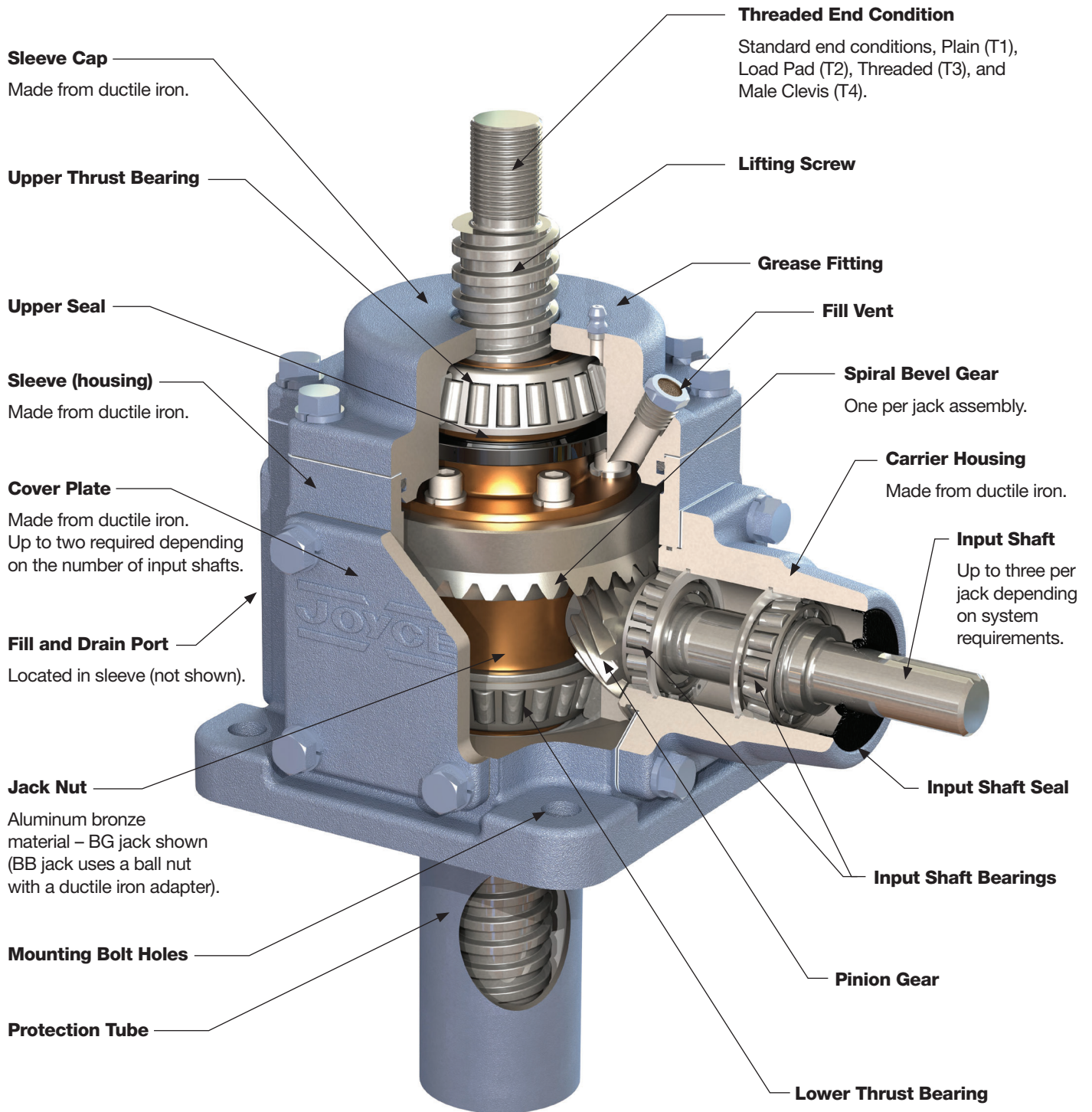

This graphic shows a Joyce Bevel Gear® jack (BG). Bevel ball actuators (BB) also use a bevel gear set. See pages 144 - 154 for more information.

# QUICK REFERENCE GUIDE

Product	Prefix	Capacity Range (tons)	Typical Lifting Speeds (IPM)	Input Shaft		Predictable Life	Inherently Self-Locking	Corrosion Resistant	Enclosed Screw	Options			
				In-Line	Right Angle					Keyed for Non-Rotation	Limit Switch	Direct Drive Motor Mount	Anti-Backlash or Limited End Play
Machine Screw Jack (pp. 18-44)	WJ RWJ DWJ DRWJ	1/8-250	14-55	■			A WJ, RWJ	C		■	■	■	■
Machine Screw ComDRIVE® (pp. 45-57)	CD DCD	2-30	2-35	■			A CD	C		■	■		■
Stainless Steel Jack (pp. 58-70)	SWJ RSWJ DSWJ DRSWJ	2-25	14-55	■			A SWJ, RSWJ	■		■	■	■	■
Metric Jack (pp. 71-79)	MWJ	1-10 (10-100 Kn)	14-55 (6-23 mm/sec)	■			■	C		■	■	■	■
Ball Screw Jack (pp. 80-101)	WBL HWBL WB HWB	1-50	14-300	■		■ Screw Only		C			■	■	D
Ball Screw ComDRIVE® (pp. 102-117)	CDB CDBL	2-30	2-55	■		■ Screw Only		C			■		D
Electric Cylinder - Standard (pp. 118-134)	ECA ECB	2 1/2-20	15-540	■		■ ECB Screw Only	B ECA	C	■		■		D
Electric Cylinder - Motor Mount (pp. 118-134)	ECA ECB	2 1/2-20	18-540	■		■ ECB Screw Only	B ECA	C	■		■	■	D
Electric Cylinder - ComDRIVE® (pp. 118-134)	ECA ECB	2 1/2-20	15-104		■	■ ECB Screw Only	B ECA	C	■		■		D
Integrated Actuator (pp. 135-142)	IA DIA BIA HBIA	1	15-350	■		■ BIA, HBIA Screw Only	■ IA	C	■		■	■	D
Bevel Gear® Jack (pp. 144-154)	BG	5-60	50-130	■	■		A Single Lead	C		■	■		
Bevel Gear Ball Screw Jacks (pp. 155-163)	BB	5-60	15-600	■	■	■		C			■		D

**A** Jacks with single lead screws are self-locking. Double lead screw jacks may lower under load.

**B** ECA jacks that are ≤ 30% efficient are self-locking.

**C** Joyce offers a variety of finishes and modifications that resist corrosion (p. 178).

**D** Oversized ball bearings can be added to limit the end play between the ball screw and ball nut.

# OPTIONS OVERVIEW FOR JACKS AND ACTUATORS



## Protective Boots

- Protection from dirt and dust
- Guard against moisture
- Guard against corrosive contaminants
- Neoprene coated nylon (std)
- Special materials available



## Lubrication

- Standard grease temp. range (40°F to 220°F)
- Low temperature option
- High temperature option
- Food grade option



## ComDRIVE® Options

- Special reducer ratios available
- Special mounting positions available
- Special motor adapters available
- Mount limit switch to gear reducers



## Mechanical Counters

- 0.001" increments (CNT0)



## Motor Mounts

- NEMA mounts available on 2-ton to 20-ton wormgear jacks and electric cylinders
- NEMA mounts included on integrated actuators
- Servo motor mounts available on 2-ton to 10-ton jacks and electric cylinders, special mounts available
- Custom mounts available



## Machine Screws

- Right hand thread standard
- L/H thread option on many models
- Special material available
- Special pitch/lead available
- Special finishes available
- Special machining options
- Special end conditions available



## Hand Wheels

- 4" - 12" dia. (standard)
- Aluminum (standard)
- Stainless steel available



## Screw Stops

- Standard on ComDrives
- Adjustable
- Bolt-on

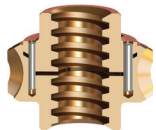

## Anti-Backlash Devices

- Available for machine screw jacks
- Available for metric (trapezoidal) jacks
- Limits lifting screw endplay



## Ball Screw Options

- Right hand thread standard
- L/H thread option on many models
- Special pitch/lead available
- Special finishes available
- Special machining options



## Potentiometers

- 0-10V (POTA)
- 4-20mA (POTB)
- 0-10V with limit switches (POTC)
- 4-20mA with limit switches (POTD)
- IP65

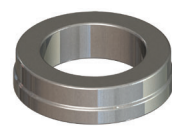

## Thrust Rings

- Used in applications where static loads exceed jack capacity



## Input Shaft (worm)

- Square or hex to fit tool
- Special lengths
- 17-4 stainless steel available
- Metric diameters available
- One side can be cut off
- Other modifications available
- Input shaft cover available



## Wormgear Sets

- Right hand thread standard
- L/H thread option on many models
- 25:1 ratio options available on several models



## Limit Switches

- Rotary cam (2-4 switches)
- SPDT standard
- DPDT available
- Explosion proof available



## Finishes

- Enamel (standard)
- Epoxy
- STEEL IT® epoxy
- Outdoor paint process
- Custom finishes available
- Anodized (250-lb to 1-ton)
- Nickel, Xylan®, Armoloy®



## Oversized Ball Bearings

- Available for ball screw jacks
- Limits screw backlash to 0.003"



## Encoders

- Standard 200 or 1024 PPR
- Quadrature wave form
- Stainless steel encoder
- Absolute encoder

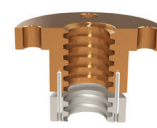

## Follower Nuts

- For KFTN jack
- For translating jack



Scan the QR Code to view options on our website.



# SELECTION GUIDE WORKSHEET JACKS AND ACTUATORS

Name \_\_\_\_\_ Title \_\_\_\_\_

Company \_\_\_\_\_ Project \_\_\_\_\_

Address \_\_\_\_\_

Phone \_\_\_\_\_ Fax \_\_\_\_\_ Email \_\_\_\_\_

## System Considerations

Number of Jacks \_\_\_\_\_ Load per Jack \_\_\_\_\_ System Load \_\_\_\_\_ Travel Speed \_\_\_\_\_

### Type of Gear Set

- Worm Gear
- Bevel Gear

### Type of Screw

- Machine Screw
- Ball Screw

### Configuration

- Upright
- Inverted

### Mounting Orientation

- Horizontal
- Vertical

### Load

- Tension (T)
- Compression (C)
- Both T & C

### Rise/Stroke

- \_\_\_\_\_ Inches
- \_\_\_\_\_ Millimeters

### Product Family

- Screw Jack
- Electric Cylinder
- Actuator

### Jack Design

- Translating
- Keyed (non-rotation)
- Traveling Nut (flush mount)

### End Condition

- T1 Plain
- T2 Load Pad
- T3 Threaded
- T4 Male Clevis

### Static Side Load

- Yes \_\_\_\_\_
- No

### Power Requirements

- Manual (Machine screws)
- Electrical \_\_\_\_V. \_\_\_\_Hz. \_\_\_\_ph.
- Other \_\_\_\_\_

## Environmental and Other Considerations

### Temperature

- Standard +40° F to +220° F
- + \_\_\_\_\_° F to - \_\_\_\_\_° F
- + \_\_\_\_\_° C to - \_\_\_\_\_° C

### Environment

- Dust
- Sand
- Oil
- Wash Down
- Dirt
- Water
- Outdoor

### Duty Cycle

- Cycles/Minute \_\_\_\_\_
- Cycles/Hour \_\_\_\_\_
- Cycles/Day \_\_\_\_\_

### Description of Cycle

- Frequency \_\_\_\_\_
- Dwell Time \_\_\_\_\_
- Other \_\_\_\_\_

### System Will Lift

- Full Stroke
- Partial Stroke
- Incrementally

### System Will Lower

- Full Stroke
- Partial Stroke
- Incrementally

### System Controls

- Motor Starter
- Synchronizing Controls
- Programmable Controls
- Custom Controls

## Options and Accessories

- Protective Boots
- Limit Switches
- Screw Stops
- Anti-backlash
- Motor Mount
- Servo Mount
- Motor/Brake Motor
- Hand Wheel
- Food Grade Grease
- Outdoor Paint
- Epoxy Paint
- Trunnion Mount
- Miter Gear Box
- Gear Reducer
- Shafting/Couplings
- Stainless Steel
- Encoder
- Counter
- Geared Pot.
- Pillow Blocks

Please list additional information and include a drawing of your application.

\_\_\_\_\_

\_\_\_\_\_

\_\_\_\_\_



Scan the QR Code to view these PDF guides online.

Joyce/Dayton Corp., P.O. Box 1630, Dayton OH 45401 • sales@joycedayton.com, FAX 937-297-7173

Name \_\_\_\_\_ Title \_\_\_\_\_

Company \_\_\_\_\_ Project \_\_\_\_\_

Address \_\_\_\_\_

Phone \_\_\_\_\_ Fax \_\_\_\_\_ Email \_\_\_\_\_

## System Information

Number of Jacks \_\_\_\_\_ Number of Motors \_\_\_\_\_

Are Jacks:  Mechanically Synchronized  Electrically Synchronized  Independently Operated

### System Environment

- Indoor/General Purpose
- Outdoor
- Wash Down
- Explosion Proof
- Coastal/Salt Spray

### Enclosure Requirement

- NEMA 4 Std. Indoor/Outdoor
- NEMA 4X Washdown
- NEMA 12 Indoor
- Other

### Approvals

- UL Listed
- CSA Approval
- Other

### What aspect of operation needs to be controlled?

- Position
- Travel Speed
- Both Position and Travel Speed
- Other (Leveling)

### Motor Requirements

Horsepower \_\_\_\_\_  
Voltage \_\_\_\_\_  
Phase \_\_\_\_\_

Frequency \_\_\_\_\_

Brake required  YES  NO

Brake Voltage \_\_\_\_\_

Brake Wiring  Internal

External (for variable frequency drives)

### Motor Operation

- Variable Speed
- Constant Speed
- Multiple Speed (preset)
- Inch/Jog (stepper)
- Synchronous

### Motor Enclosure

- Totally Enclosed TEFC
- Wash Down
- Explosion Proof

### Primary Control Requirement

- Momentary Operation
- Constant Torque
- Programmable Positions
  - One to Four
  - More than Four
- Accuracy for Positioning
  - \_\_\_\_\_ +/-  inch  mm

- Maintained Operation
- Synchronized Travel
  - Tolerance \_\_\_\_\_ +/-  inch  mm
- Variable Speed
  - Range of frequency \_\_\_\_\_
- Soft Start Operation
  - Rate (in/min<sup>2</sup>) \_\_\_\_\_
  - Number of starts/hour \_\_\_\_\_

### Control Options

- Alarms  Indicators  Pendant Control  Wireless Control  HMI/Touch Screen

### Other Considerations

Please describe the order of operation and other functional requirements of your system:

\_\_\_\_\_

\_\_\_\_\_

\_\_\_\_\_



Scan the QR Code to view these PDF guides online.

Joyce/Dayton Corp., P.O. Box 1630, Dayton OH 45401 • sales@joycedayton.com, FAX 937-297-7173

- 1. Maximum Input RPM** – Input rotational speeds up to 2400 RPM are permissible for jacks and actuators depending on load, duty cycle, and other factors specific to the application. Use our exclusive JAX® Online browser-based software to evaluate jacks and systems having input RPM values  $\geq$  to 1750 RPM.
- 2. Side Load** – Standard jacks and actuators are not designed for dynamic side loads. The load must be positioned axially. Static side loads are limited. Contact Joyce for technical assistance.
- 3. Duty Cycle** – Relationship between operation time and rest time. The allowable duty cycle for jacks and actuators is based upon several application variables such as load, speed, and temperature. Consideration must be given to the severity of the duty cycle during the product selection phase. Our Application Engineers are available to discuss your requirements.
- 4. Self-Locking Jacks** – Screw jacks that require power to raise or lower. Exceptions include machine screw jacks having double lead screws and ECA electric cylinders that are more than 30% efficient and all ball screw jacks. A brake must be used on the input shaft of any jack that is not self-locking. A brake should also be included for applications that expose the jack or actuator to vibration. Contact Joyce for more information.
- 5. Jacks That Require a Brake Motor** – Any jack that will lower under load requires a brake motor. This includes ball screw jacks (WB, HWB, WBL, HWBL), ball screw ComDRIVES® (CDB, CDBL, CDHB, CDHBL), ball screw electric cylinders (ECB), ball screw integrated actuators (BIA, HBIA), and bevel ball actuators (BB). Machine screw jacks with double lead screws and WJ500 jacks may also require brakes to hold position.
- 6. Travel Speed Limitations** – Typical travel speeds for various jacks and actuators are measured in inches per minute (IPM). Speeds depend on the input RPM, load, internal ratio and lead of the screw. Maximum allowable travel speeds for machine screw jacks are typically slower than ball screw jacks. Wormgear jacks typically have slower travel speeds than bevel gear jacks. Refer to the JAX Online browser-based software for more detail or contact Joyce to talk with an application engineer.
- 7. Maximum Screw Length** – Maximum distance from the base of the jack to the end of the extended screw. It is limited by the column load in compression. Refer to column load charts throughout this catalog or use the JAX Online browser-based software. Contact Joyce with questions.
- 8. Calculated Life for Machine Screws** – There is no formula available to calculate the life of a machine screw. If a calculated life for the screw jack is required, specify ball screw jacks, ball screw ComDRIVES®, ball screw electric cylinders, ball screw integrated actuators, or bevel ball actuators.
- 9. Calculated Life for Ball Screws** – The calculated life for ball screws is based on the ball nut life. This information is available for all ball screw jacks, ball screw ComDRIVES®, ball screw integrated actuators, bevel ball actuators, and ball screw electric cylinders (ECB). Register at [joycedayton.com/register](http://joycedayton.com/register) to use JAX Online browser-based software, or contact Joyce with your requirements.
- 10. Screw Stops** – Stops are offered as options for screw jacks and actuators, and are not to be used as operating limits. Engaging the stop may prevent damage to your structure but will most likely damage the jack. To control jack or actuator travel, include travel limits in the system design. Stops may increase the closed height of the jack and the length of the protection tube. Refer to specific ordering sections in the catalog or contact Joyce for more information.  
**Note:** *Adjustable screw stops are standard on most Joyce ComDRIVE® jacks. (The extending stop on 15- and 50-ton jacks and ComDRIVES is threaded on and functions as a fixed stop.)*
- 11. Adjustable or Fixed Screw Stops** – Adjustable screw stops are used most frequently. They are secured against the lifting screw with set screws and can easily be repositioned. Fixed screw stops are positioned at the factory and their position cannot be adjusted. Fixed extending screw stops, when used, are standard on extending stops for both 15- and 50-ton machine screw jacks.
- 12. Hard Stops** – Jacks are not designed to operate into a hard stop. Sudden impacts and shock loads may cause damage to jacks and actuators. Customers are responsible for providing travel limits to avoid this situation.
- 13. Standard Operating Temperature** – The standard operating temperature range for most products is 40°F – 220°F. There are some exceptions. For operation outside this range, special lubricants and seals can be provided.
- 14. Lubrication of Wormgear Jacks** – Standard wormgear jacks are lubricated with NLGI grade #1 grease prior to shipment. Specific information and commercial brand names can be found in the Operation & Maintenance Manuals, which are available at [joycedayton.com](http://joycedayton.com).
- 15. Lubrication of Bevel Gear Jacks** – Bevel Gear jacks use both NLGI grade #1 grease and oil. The upper bearing and jackscrew are grease lubricated while the remaining internal components are oil lubricated. These jacks are grease lubricated prior to shipment; however, oil must be added to the unit prior to operation. Bevel Ball Actuators are typically grease lubricated with NLGI grade #1 grease prior to shipment.
- 16. Horizontal Mounting** – When jacks are mounted horizontally, Joyce recommends that the input shaft (worm) be mounted below the lifting screw and parallel with the horizon. This position provides the most lubrication to the input shaft (worm), and to both worm shaft bearings. The load capacity of the jack may be reduced when the lifting screw is mounted horizontally. Bevel gear jacks are designed to be mounted vertically with the flange base down but can be adapted for other mounting orientations. Consideration must be given to the position of vents and oil fittings to ensure proper lubrication levels.
- 17. High Screw RPM and Long Screw Lengths** – Keyed for traveling nut (KFTN) jacks with long screw lengths require additional support when the screw rotates at high RPM.
- 18. Direct Drive Considerations** – Whenever the input worm shaft is driven directly from a motor, designers should consider the starting torque capacity of the motor, handwheel, or other power train device. Torque values calculated in JAX Online software are based on running torque and selection of motor horsepower may require additional consideration.

### Technical Questions

Our qualified and experienced Application Engineers are available Monday through Friday, 8 a.m. - 5 p.m., EST.

Contact Joyce to discuss specific application questions and technical questions.

- [sales@joycedayton.com](mailto:sales@joycedayton.com)
- 937-294-6261

### Tools for Engineers and Designers

Register at [joycedayton.com/user/register](http://joycedayton.com/user/register) to access 2D/3D drawing software and our exclusive JAX® Online browser-based software.

### Column Loading Capacity

The type of load on a jack, and the way the jack is mounted, affects its load bearing capacity. There are two types of possible jack loads, tension and compression. A jack is under tension when its load pulls the screw away from the jack. It is under compression when the load pushes the lifting screw toward the jack (see diagrams). A jack can be under tension or compression regardless of jack positioning (i.e., vertical, horizontal, upright, or inverted).

When tension loaded, the jack retains full rated capacity. Under compression loads, the screw may not be able to support full capacity. For example, a 2-ton jack with a 15" screw length will be limited to 2293 pounds in compression, about half the jack's capacity. In compression the load, screw length and jack mounting configuration determine the load capacity of the screw. The examples shown illustrate four common mounting configurations.

### Unguided

If the screw is the only support for the load, it is considered unguided. The screw must be large enough to support the load and prevent buckling. On the Column Loading charts, use the row labeled "unguided" for the allowable lengths for this design. The Column Loading charts are located within the appropriate product sections of the catalog.

### Trunnion Mounting

In a trunnion mounting arrangement, the screw has a pivot on the end and the jack body is mounted on a large pivoting frame, or trunnion. This type of mounting is particularly common in the antenna industry. In practice, the pivot should be as close to the centerline of the internal nut as design permits. This will eliminate moment loads caused by loose threads. Use the "trunnion" row on the Column Loading charts found within the appropriate product sections of the catalog.

### Guided

Guided loading is often termed "fixed-fixed" loading. With guided loading, both ends of the column are rigidly held – the jack body is bolted firmly to a sturdy base, and the load travels on slides, bearings, rollers or other means. The guides should be snug enough to prevent any side load or moment load from reaching the screw. Use the "guided" row on the appropriate Column Loading charts.

### Double-Clevis Mounting

Double-clevis jacks have less load capacity than the other common mounting configurations. A double-clevis jack has pivots or clevises at both ends: one on the screw tip and one on the end of the protection tube. This tends to weaken it as a column by creating eccentric loads on the screw. This eccentricity tends to increase with greater distance and higher loading. For this reason, double-clevis jacks are limited both in

capacity and maximum length. Double-clevis mounting differs from trunnion mounting because the pivot is located farther from the jack body. The Column Loading charts do not apply for this mounting. Please consult Joyce for load bearing information.

### How to use the Column Loading charts:

Note: Charts for machine screw jacks, machine screw ComDRIVES®, metric screw jacks, ball screw jacks, ball screw ComDRIVES®, stainless steel jacks, bevel gear jacks, and bevel ball actuators are located within the specific product section of the catalog. These charts only apply to jacks with axial loads. *For side loads, offset loads, and horizontal mounting, contact Joyce.*

1. Determine the type of jack you wish to use and locate that column load chart which is found near the beginning of each product section.
2. Determine the proper mounting arrangement for your application. Locate the appropriate row and find the screw length at the bottom of the chart.
3. Find the load you need to move (in pounds or kilonewtons) on the left side of the chart.
4. Find the point on the chart where the load and length intersect. Choose a jack whose line is on or above this intersection.
5. Add the length of the end condition you have chosen and any additional screw extension to the screw length to find the "unbraced" screw length. Verify your selection using the unbraced length.

### Example:

A jack must lift 5 tons (10,000 pounds) over a distance of 31 inches. The load places the screw in compression. The jack is mounted firmly by its base, and the load is attached to a load pad (Type 2 end) and is not guided.

1. In this example, a machine screw jack will be used so locate the Column Loading chart for machine screw jacks on page 24.
2. Look at the "unguided" row at the bottom of the machine screw jack Column Loading chart and find the 31" mark.
3. From this, the 10-ton double lead jack is selected. Look at the dimensions from the jack body for the Type 2 end for this jack. The Type 2 end adds 2" from the top of the jack to the end of the screw. Thus the total unbraced length of the screw is  $31" + 2" = 33"$ .
4. Use this new unbraced screw length to verify your selection. In this case, the intersection point still falls below the 10-ton double lead jack line, so this selection is correct.

### Compression

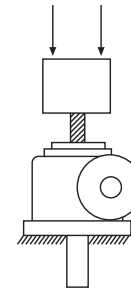

### Tension

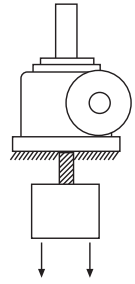

### Unguided

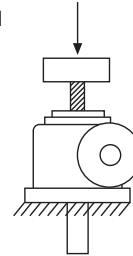

### Trunnion Mount

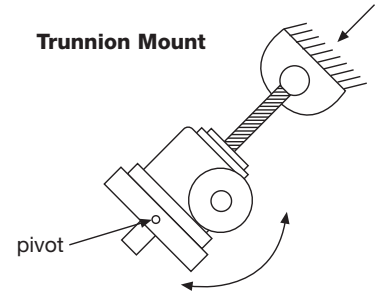

### Guided

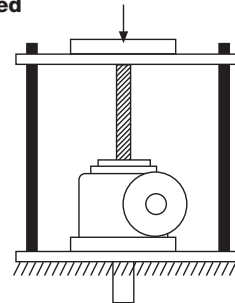

### Double-Clevis

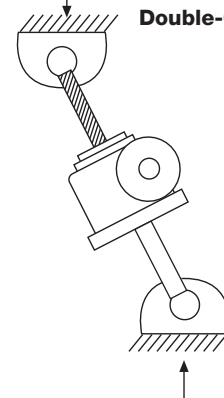

## Joyce Translating Design Jacks

A driven worm acts on an internal wormgear, which in turn drives a lifting screw to extend or retract. As the lifting screw translates through the body of the jack, inherent screw rotation is prevented by an attached load or mounting structure either of which is anchored to resist rotation.

This design is available for:

- Machine Screw Jacks
- Machine Screw ComDRIVES®
- Stainless Steel Jacks
- Metric Screw Jacks
- Ball Screw Jacks
- Ball Screw ComDRIVES®
- Bevel Gear Jacks
- Bevel Ball Actuators

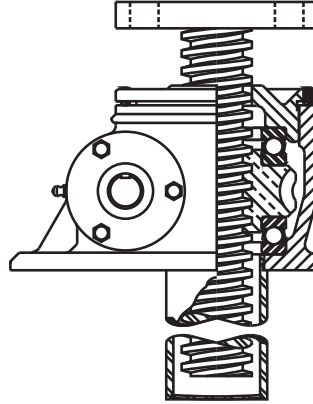

## Joyce Keyed Design Jacks

Some loads do not prevent lifting screw rotation. These applications require a keyed jack. A key, fixed to the jack housing and inserted into a keyway milled into the lifting screw, forces the lifting screw to translate without rotating. Several dimensions of the keyed jack differ from the translating jack – check the keyed jack drawings for each jack model.

This design is available for:

- Machine Screw Jacks (except WJ250)
- Machine Screw ComDRIVES®
- Stainless Steel Jacks
- Metric Screw Jacks
- Bevel Gear Jacks

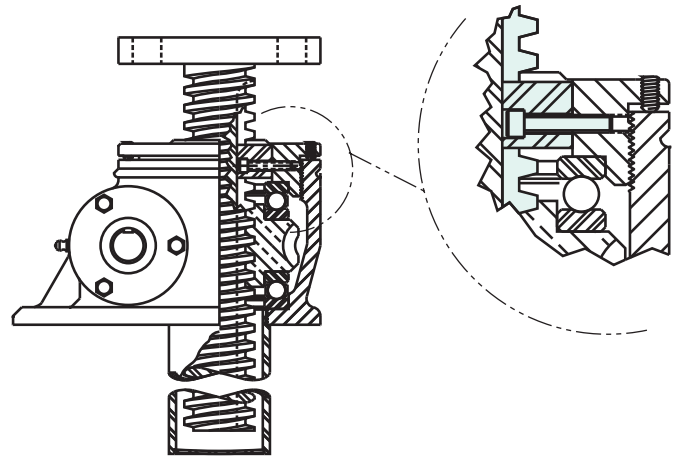

## Joyce Keyed for Traveling Nut (KFTN) Jacks

A keyed for traveling nut jack (sometimes referred to as a rotating screw jack) features a lifting screw keyed to the wormgear as a single unit, forcing the lifting screw to rotate, but not translate. A flanged traveling nut, attached to the load, is driven by the rotation of the lifting screw. This type of jack is ideal for applications that cannot accommodate a screw protection tube or that require a flush mount. Refer to the keyed for traveling nut (KFTN) dimensional drawings for each jack model.

This design is available for:

- Machine Screw Jacks
- Machine Screw ComDRIVES®
- Stainless Steel Jacks
- Metric Screw Jacks
- Ball Screw Jacks
- Ball Screw ComDRIVES®
- Integrated Actuators
- Bevel Gear Jacks
- Bevel Ball Actuators

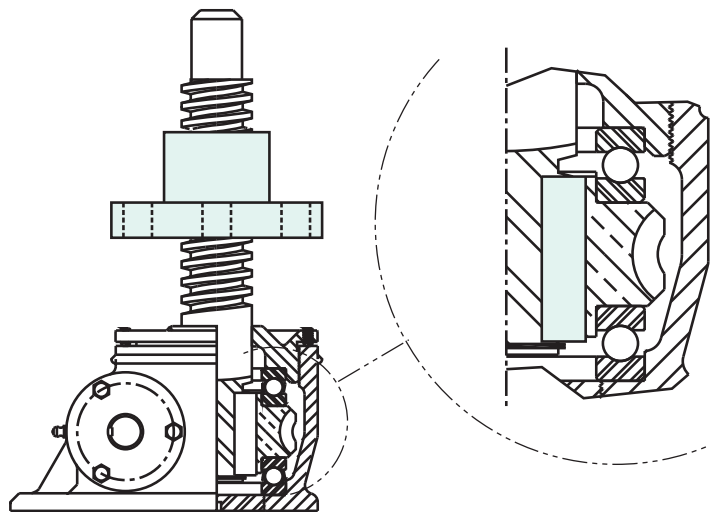

Operating Torque Constants and Tare Torque values can be found on specification pages.

Use the following formula to calculate horsepower:

$$(RPM \times Load (lb) \times Operating Torque Constant + Tare Torque) / 63025 = \text{Horsepower}$$

### Example 1 – Calculate the horsepower needed to move a load on a single jack (WJT242).

WJT242 has a torque constant of 0.009W with (W) representing the load in pounds and a tare torque of 4 inch-pounds (page 22). Using 350 RPM on the input shaft and a 2000-pound load results in the following horsepower equation:  $(350 \text{ RPM} \times 2000 \text{ lb} \times 0.009 + 4 \text{ in. lbs}) / 63,025 = 0.10 \text{ HP}$

Note: Unlike bevel gear jacks and bevel ball actuators, wormgear style jack input torque requirements vary with input speed, therefore the constants listed in the catalog are only accurate for the RPM listed. To calculate horsepower at speeds other than those listed, please refer to the free JAX® Online browser-based software or fill out a selection guide (page 8) and contact Joyce .

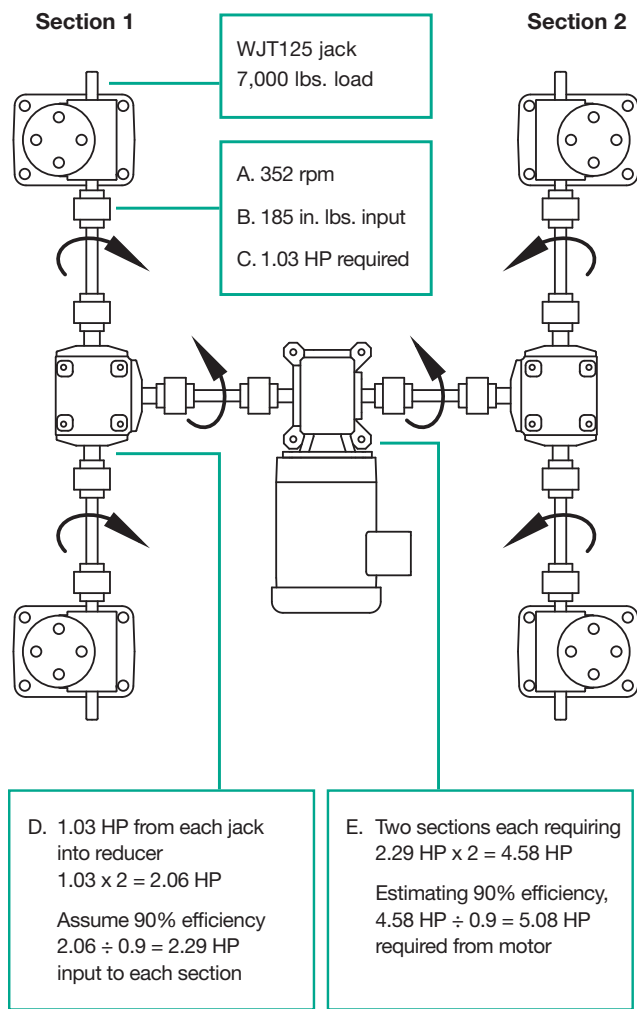

### Example 2 – Calculate the horsepower needed to move a system load (WJT125).

Find the horsepower required to raise a system load of 28,000-pounds, a distance of 10 inches, at a speed of 11 in./min., using four WJT125 jacks (page 22). The load per jack is 7000 pounds.

- Determine input speed:  
 $32 \text{ turns of the input shaft} = 1 \text{ inch of linear travel.}$   
 $(32 \text{ turns/inch} \times 11 \text{ inches/min} = 352 \text{ RPM input})$
- Determine the input operating torque plus tare torque for one jack:  
 $(0.025 \text{ in. lbs.} \times 7,000) + 10 \text{ in. lbs} = 185 \text{ in. lbs}$
- Determine the input horsepower for one jack:  
 $(352 \text{ rpm} \times 185 \text{ in. lbs}) / 63,025 = 1.03 \text{ HP per jack}$

To calculate the horsepower required when operating a jack system, it is usually easiest to separate the system into sections. For example, the “H” system can be viewed as two jack systems joined by a speed reducer in the center.

Always remember to take into account the inefficiencies of miter boxes and gear reducers when calculating system horsepower requirements. (For this exercise use 90% efficiency for miter boxes and gear reducers, but in actual systems efficiencies may differ.)

- Determine horsepower required for Section 1:  
 $\text{Total horsepower required for the left side of the system} = 1.03 \text{ HP per jack} \times 2 \text{ jacks} = 2.06 \text{ HP}$   
 $2.06 \text{ HP} / .9 = 2.29 \text{ HP}$  required into miter box of Section 1.  
 Since Sections 1 and 2 are identical, Section 2 also requires 2.29 HP.
- Determine horsepower required for Sections 1 and 2:  
 $2.29 \text{ HP} + 2.29 \text{ HP} = 4.58 \text{ HP}$

Account for the inefficiency of the central gear reducer to determine the total system horsepower requirement.

$$4.58 \text{ HP} / 0.9 = 5.08 \text{ HP required to operate this system}$$

### SHAFT MOUNTED OPTIONS

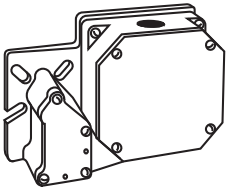

#### Rotary Cam Limit Switches

See page 170

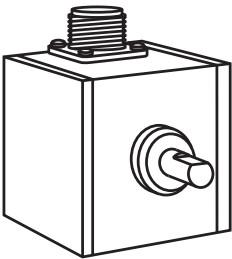

#### Encoders

- Standard, 200 or Optional 1024 PPR
- Stainless steel Encoder 1024 PPM
- Absolute Encoder

See pages 172-173

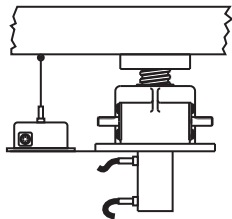

#### String Encoder and other Linear Displacement devices

#### Proximity Switches

Contact Joyce

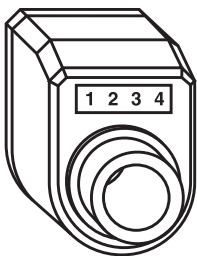

#### Mechanical Counters

See page 176

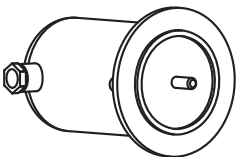

#### Geared Potentiometer 0-10V or 4-20Ma

See page 171

Joyce jacks and actuators are at the heart of linear motion systems in thousands of applications worldwide.

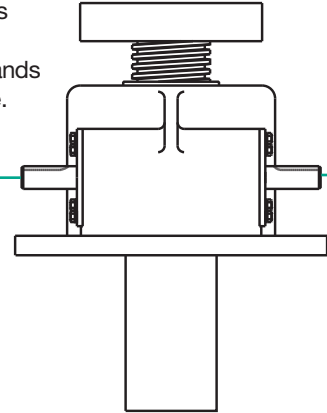

### ACCESSORIES

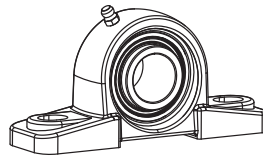

#### Pillow Block and Flange Block Supports

See page 180

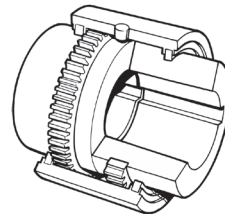

#### Shafts and Couplings

See pages 184-187

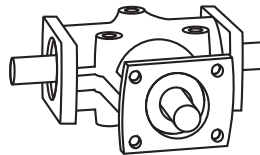

#### Miter Gear Boxes

See pages 181-183

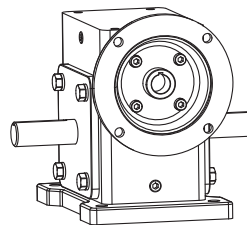

#### Speed Reducers

Contact Joyce

### DRIVE OPTIONS

#### Hand Wheels

See page 176

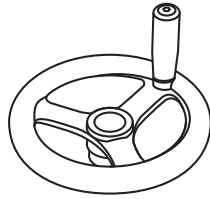

#### Square or Hex ends on worm input

Contact Joyce

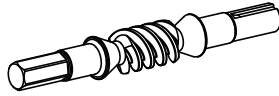

#### Specialty Motors

- AC or DC
- Air
- IEC Frame
- Gear Motor
- International Voltages
- Single Phase
- Brake Motors

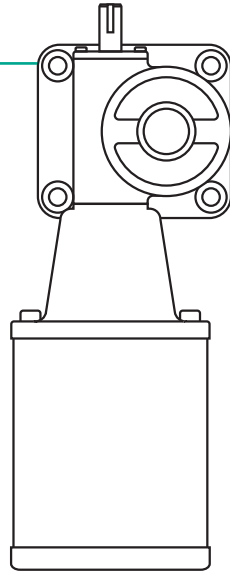

#### Direct Drives

- Stock AC Motor Mounts  
See page 175
- Servo Motor Adapters  
See page 174
- Stepper Motor Adapters  
Available
- Custom Adapters

#### ComDRIVE®

**Self-contained actuators combine jack, gear reducer and motor in a single compact unit.**

- Machine Screw ComDRIVE®  
See pages 45-57
- Ball Screw ComDRIVE®  
See pages 103-117
- Electric Cylinder ComDRIVE®  
See pages 118-134

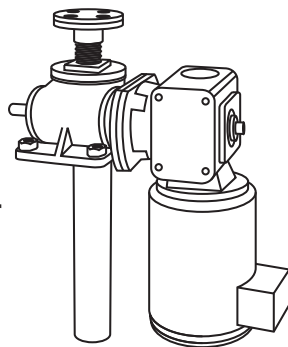

### MOTOR CONTROLS

#### Variable Speed Positioning System (VSPS)

- 10 Programmable Preset positions  
See page 189

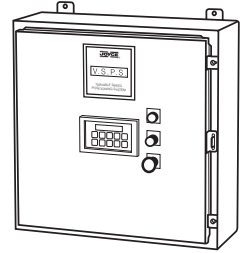

#### Custom Controls include Synchronized Systems, Positioning Systems, and Leveling Systems

Contact Joyce

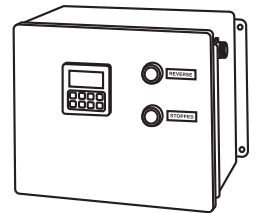

#### Motor Starters

- Momentary Contact Motor Starters  
See page 188

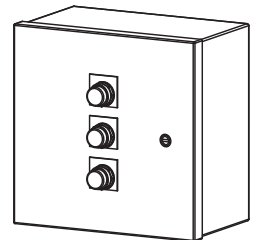

#### Actuator Controls

- 120 VAC - 120 VAC
- 120 VAC - 12 VDC
- 12 VDC - 12 VDC  
See page 189

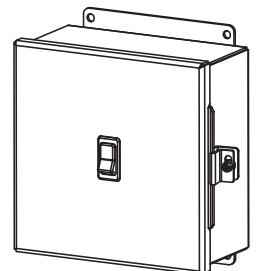

## 1. What is the difference between upright and inverted jack configurations?

The difference between an upright and an inverted jack is the location at which the lifting screw exits the jack relative to the jack base. For example, an upright jack's lifting screw exits the jack opposite the base. An inverted jack's lifting screw exits the jack on the same side as the base. The choice between inverted and upright jack is dependent upon the application.

Note: An upright jack mounted upside down is still referred to as an upright jack.

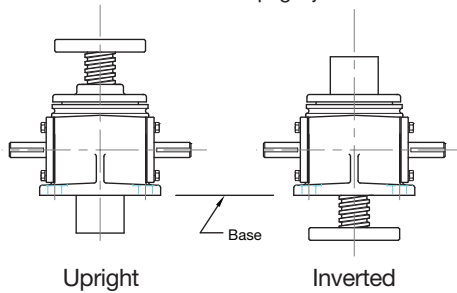

## 2. How can I determine worm shaft rotation extending the lifting screw?

Refer to the views of the standard jack with right hand screw threads below:

- For an Upright jack:  
CCW rotation of right input shaft extends the lifting screw.  
CW rotation of the left shaft extends lifting screw.
- For an Inverted jack:  
CW rotation of right input shaft extends lifting screw.  
CCW rotation of the left shaft extends lifting screw.

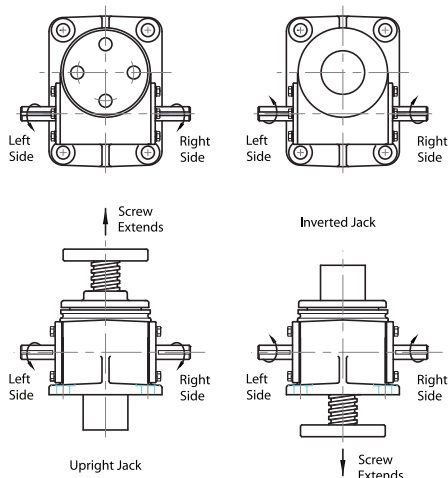

**3. How is the linear travel speed calculated?** Each screw jack and actuator has an inherent number of input shaft turns per inch (TPI) of screw travel. TPI is the result of the jack's gear ratio divided by the lifting screw lead. The TPI can be found on jack specification pages at the beginning of many product sections. A model WJT242 has a TPI of 96. If 350 RPM is applied to the input shaft, the resultant linear speed of travel is  $350/96$  or 3.65 inches per minute.





**4. Are screw jacks lubricated prior to shipment?** All Joyce machine screw jacks and ComDRIVES®, ball screw jacks and ComDRIVES®, bevel ball actuators, integrated actuators, and electric cylinders are lubricated with an extreme pressure NLGI grade #1 grease before leaving the factory.

Bevel gear jacks are lubricated with NLGI grade #1 grease and oil. The upper bearing and jackscrew are grease lubricated while the remaining internal components are oil lubricated. They are grease lubricated prior to shipment; however oil must be added to the unit prior to operation.

Linear actuators (LA) are lubricated for life.

## 5. What are the standard end conditions for screw jack lifting screws?

The following standard end conditions are available on Joyce screw jacks:

- Type 1  
plain turned end 
- Type 2  
load pad with mounting holes 
- Type 3  
male threaded end 
- Type 4  
male clevis end 

Contact Joyce for information about custom end conditions.

## 6. How is the clevis, T4 end, positioned on a keyed jack?

- Standard clevis mounting position – the hole in the clevis end is parallel with the worm input shaft.
- Optional mounting position – the hole in the clevis end is perpendicular to the worm input shaft.

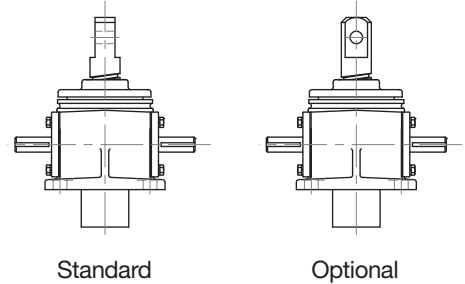

## 7. How is the load pad, T2 end, positioned on keyed jacks?

- Standard load pad mounting position – the holes on the load pad are on the jack centerlines.
- Optional load pad mounting position – the holes on the load pad end straddle the jack centerlines.

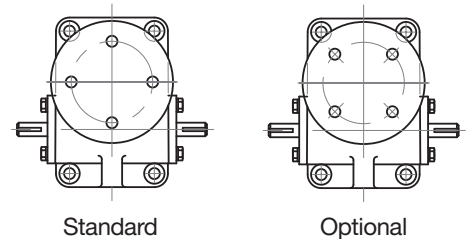

**8. Can I buy a jack with a clevis on both ends?** Yes. When freedom of movement in two axes is required, a double clevis jack may be specified.

- Double clevis jacks incorporate a clevis machined or pinned on the screw end and also a clevis welded to the protection tube.

Screw travel is limited. Contact sales@joycedayton.com for more information.

- Electric cylinders, integrated actuators, and linear actuators are also available with a clevis on both ends.

**9. What is meant by “self-locking”?**

Self-locking is a term used to describe jacks that require power to move in either direction. They hold their position when power to the system is off. See page 10 for more details.

**10. What if the jack is not self-locking?**

A brake is required on the input shaft of any jack that may lower under load (ball screw jacks, double-lead Acme screw jacks, integrated actuators, and electric cylinders that are more than 30% efficient). See page 10 for more details.

**11. How much side load can be placed on a screw jack?**

Standard jacks and actuators are not designed for dynamic side loads. The load must be positioned axially. Static side loads are limited. Contact sales@joycedayton.com for technical assistance. See page 10 for more details.

**12. How much backlash is in a machine screw jack?**

In machine screw jacks there are two types of backlash: worm to wormgear backlash (typically 8-15° worm rotation), and lifting screw to nut backlash, sometimes called endplay (up to 0.020 inches on new standard jacks). Refer to the JAX® Online browser-based software for information about specific jacks.

**13. Can I reduce machine screw backlash?**

Yes, screw backlash can be adjusted on translating and keyed style machine screw jacks via one of the following anti-backlash options: standard split-nut design; A90 external nut adjustment; or A95 design. See page 181.

**14. What is screw lead error?** The deviation from the mathematical lead expressed in inches per foot cumulative.

**15. What is the amount of lead error in a standard lifting screw?** Rolled Acme screws have up to .010 in/ft cumulative error, milled Acme screws have up to 0.003 in/ft cumulative error; and ball screws have up to 0.007 in/ft cumulative error. Contact Joyce for more information.

**16. Are Joyce/Dayton jacks and actuators user-serviceable?** The level to which products can be serviced in the field varies from product to product. Refer to the product Operation & Maintenance Manuals or contact Joyce for more information.

**17. What motor options are available?**

Motor options vary among product lines. Customers can use AC 3-phase, AC single-phase, DC motors, international voltage motors and others. Let us know your requirements.

The motors on linear actuators are an integral component. They are available in 120 VAC, or 12 VDC.

**18. What is the clutch on a linear actuator and how is it used?**

A screw clutch device is an option on linear actuators (if they do not have limit switches). This device allows the screw to turn if the actuator is operated against a hard stop. This is an emergency protection device, not to be used repeatedly as an end of travel stop.

**19. Are limit switches preset?** No.

- Shaft-mounted rotary cam limit switches must be set to the required positions during installation.
- Limit switches on linear actuators must be set after the actuators have been installed in order to tailor the stop position to the individual application.

**20. What do I need to consider when ordering a bellows boot to protect the lifting screw?**

- Closed height dimensions may increase when boots are added.
- The customer must specify boot collar diameter when ordering bellows boots for KFTN jacks.
- Zippered boots are also available.
- Special boot material is available.
- Horizontal screw applications may require boot guides.
- See pages 170-173

**21. Are jacks and actuators corrosion-resistant?**

Stainless steel jacks are inherently corrosion resistant. All exposed surfaces are stainless steel and aluminum bronze. Most other jacks can be modified with special finishes, coatings, and seals. Contact Joyce with your requirements. See Finishes on page 182.

**22. What is a follower nut assembly and when is it helpful to have one?**

Follower nut assemblies allow customers to gauge the wear on the wormgear screw thread of translating jacks and on the traveling nut screw thread of KFTN jacks. This allows customers to replace the nut before its threads wear too thin to support the design load. These assemblies generally consist of a gear nut or traveling nut pinned to a second nut of dissimilar material. A preset gap separates the two nuts. As the wormgear or traveling nut threads wear, the preset gap narrows. The assembly is replaced when the gap measurement reaches the design limit. Follower nut assemblies are designed for specific applications. Contact Joyce for more information.

