

BEVEL GEAR BALL SCREW JACKS

To properly size bevel ball jacks, follow the design tips found on page 161, and refer to the Column Load and Life Expectancy charts (pages 162 and 163). Use JAX® Online software to determine the dynamic capacity of bevel ball jacks or contact Joyce.

Joyce high-efficiency bevel gear ball screw jacks (BB) are designed for near-continuous duty operation. BB series bevel ball jacks provide higher speeds and less heat generation than other mechanical actuators and require a brake motor or other external locking device to hold position. They also offer more precise positioning and repeatability than hydraulic cylinders.

Bevel gear ball screw jacks are available in 7.5-ton to 100-ton static capacities and are able to attain travel speeds of up to 48 feet per minute. The ball screw and ball nut have a fully predictable J-10 life expectancy. Standard jacks have right hand ball screws. Left hand ball screws are available as an option. A threaded end condition is standard on translating bevel ball actuators; load pad, plain and clevis ends are also available. KFTN designs have a plain turned end condition.

Bevel gear ball screw jacks are ideal for either single operation or multi-actuator systems. As many as three output shafts may be specified for mounting motors, limit switches, readout devices and other accessories. See page 190 for an example of a bevel gear jack system. Note that right hand and left hand screw threads are alternated in the layout.

Many options are available including oversized ball bearings, which can be specified to reduce endplay between ball screw and ball nut. All jack designs can be fitted with protective boots.

Joyce can customize bevel gear ball screw jacks to meet your requirements.

Joyce offers Bevel Gear Ball Screw Jacks in the following designs:

- **Translating**
- **Keyed for traveling nut (KFTN)**

A guide for ordering is on page 156.



Scan the QR Code to view this product on our website.

BEVEL GEAR BALL SCREW JACKS ORDERING INFORMATION

Instructions: Select a model number from this chart.



Joyce Bevel Ball Jacks	
BB150	
BB225	
BB300	
BB400	





Evaluate column load (p. 158).
 Evaluate ball nut life (p. 159).
 Detailed product information (pp. 160-161).
 Right hand ball screws standard.



Bevel Ball Jack Rise
Rise is travel expressed in inches and not the actual screw length.

Screw Stops (p. 10) and Boots (pp. 166-168)
Extending Screw Stops are optional on bevel ball jacks. When specified, the closed height of the jack and protection tube length may be increased.

Sample Part Number: **BB225U3S-12-XXXX-STDX-XXXX-B**

Actuator Configuration	
 U=Upright	 I=Inverted

End Conditions			
 1=T1 (plain end)	 2=T2 (load pad)	 3=T3 (threaded end)	 4=T4 (male clevis)

Actuator Design		
 S=Translating	 Keyed for Non Rotation is not a standard option	 N=Traveling Nut

Encoders (pp. 172-173)	
ENCA =Absolute Encoder 0-10 VDC, programmable	
ENCB =Absolute Encoder 4-20mA, programmable	
ENCC =Absolute Encoder CAN Open	
ENCD =Absolute Encoder SSI	
ENCS =Stainless Steel Incremental Encoder 1024 PPR	
ENCX =Incremental Encoder 200 PPR ENCY =Incremental Encoder 1024 PPR	

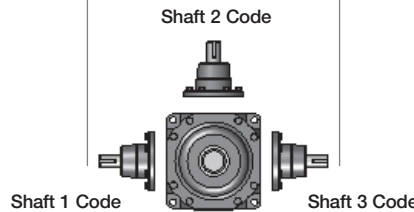









Shaft Codes
Three shaft codes must be specified for each jack. Electronic and mechanical limit switches may be substituted for the shaft code per the tables on this page.
STDX – Standard
XXXX – Input shaft not required
CUST – Custom
When ordering with only one input shaft, it is recommended to order the following configuration: XXXX-STDX-XXXX.

Additional Options*
X =Standard Actuator, no additional options
S =Additional Specification Required (comment as necessary)
Protective Boots pp. 166-168
B =Protective Boot
D =Dual Protective Boot
Finishes p. 178
F1 =Do not Paint
F2 =Epoxy Paint
F3 =Outdoor Paint Process
Ball Screw
L =Left Hand Screw
Screw Stops
ST0 =Extending Stops
* Specify as many options as needed

Mechanical Limit Switches (p. 170)

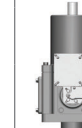
Ordering Example: **LA13**

Models		Number of DPDT Switches (see p. 170)	Available Positions							
Model	Code		1	2	3	4	5	6	7	8
LS7-402	LI	NOTE: Will always be 0 for LS7 models								
LS8-402	LA									
LS8-404	LB									

Note: All BB jacks are available with all mounting positions.

BEVEL GEAR BALL SCREW JACKS SPECIFICATIONS & TIPS

Model	Dynamic Capacity	Static Capacity (Lbs)		Screw Dia./Lead	Bevel Gear Ratio	Pinion Turns for 1" Travel	Pinion Torque (Raising)	Pinion Torque (Holding)	Screw Torque	Actuator Efficiency	Base Weight (Lbs)	Add for each inch of travel	
		Upright Assembly Screw in Tension	Upright Assembly Screw in Compression										
BB150	Please use JAX® Online software or contact Joyce	15,000	15,000	1.50/.25	2.69:1	10.77	.022W*	.018W*	.044W*	72.2%	52	0.7	
BB225		30,000	30,000	2.25/.50	2.15:1	4.31	.054W*	.044W*	.089W*		200	2.6	
BB300		42,500	70,000	3.00/.66	3.52:1	5.34	.044W*	.035W*	.117W*		360	3.2	
BB400		200,000	200,000	4.00/1.00	3:1	3.00	.078W*	.063W*	.117W*		740	4.8	
			Inverted Assembly Screw in Tension	Inverted Assembly Screw in Compression									
BB150		15,000	15,000	1.50/.25	2.69:1	10.77	.022W*	.018W*	.044W*	72.2%	52	0.7	
BB225		30,000	30,000	2.25/.50	2.15:1	4.31	.054W*	.044W*	.089W*		200	2.6	
BB300		70,000	42,500	3.00/.66	3.52:1	5.34	.044W*	.035W*	.117W*		360	3.2	
BB400	200,000	200,000	4.50/1.00	3:1	3.00	.078W*	.063W*	.117W*	740		4.8		

Important Note: Bevel Ball Jacks are not self-locking. Brake motors or external locking systems are required.

*W: Load in Pounds.

Pinion Torque (raising): The torque required to continuously raise a given load.

Pinion Torque (holding): The torque required to hold a given static load in position.

Screw Torque: The torque required to resist screw rotation (translating design) and traveling nut rotation (KFTN design).

Lead: The distance traveled axially in one rotation of the lifting screw.

Pitch: The distance from a point on the screw thread to a corresponding point on the next thread, measured axially.

For additional sizes contact our team at:
sales@joycedayton.com or call (937) 294-6261.

Design Tips

- Determine the load to each bevel ball jack.
- Determine the orientation and type of load; for instance, from the chart above it may be an upright compression load or an inverted compression load.
- Jax® software can be used to determine the following:
 - The allowable static compression load for a given rise (or use Column Loading Chart on page 158)
 - The allowable dynamic load for a given rise
 - Ball nut life (or use Life Expectancy of the ball screw chart on page 159)
 - System horsepower and torque – also see item #4
- When a direct motor drive is used in a system, consideration must be given to the input starting torque requirements and the motor horsepower will need to be increased accordingly (JAX® software may require additional scrutiny). Contact sales@joycedayton.com for assistance.
- When selecting bevel ball jacks for an interconnected row or system (p. 190), careful attention must be given to the input and output shaft rotations. For example, if the input shaft rotation on the first bevel ball jack is clockwise, the output shaft(s) on that same bevel ball jack will rotate counter-clockwise. To insure all actuators raise and lower in unison, alternating bevel ball jacks must be specified with right and left hand ball screw threads. For example, if you need five bevel ball jacks interconnected in a straight line and the first bevel ball jack is right hand, the third and fifth bevel ball jack will also need to be ordered as right hand and the second and fourth bevel ball jack will need to be ordered as left hand. Bevel ball bevel ball jacks are supplied standard with right hand ball screws. To order the left hand ball screw option, add an "L" to the end of your bevel ball jack part number as shown on page 156.
- Bevel ball jacks are not self-locking. They will lower under load. A brake motor or other external locking system is required.
- Bevel ball jacks are furnished with one input shaft (pinion) in position #2. Bevel ball jack may be ordered with up to three input shafts located at any combination of positions # 1, 2, or 3.
- Translating bevel ball jack are designed for grease lubrication. The upper bearing is grease lubricated through a fitting on top of the jack. Light oil must be applied directly to the lifting screw.
- Typically bevel ball jacks are mounted upright with the jack base plate parallel to the horizon. If the base plate is oriented any other way, contact Joyce for lubrication and other instructions.

BEVEL GEAR BALL SCREW JACKS COLUMN LOADING

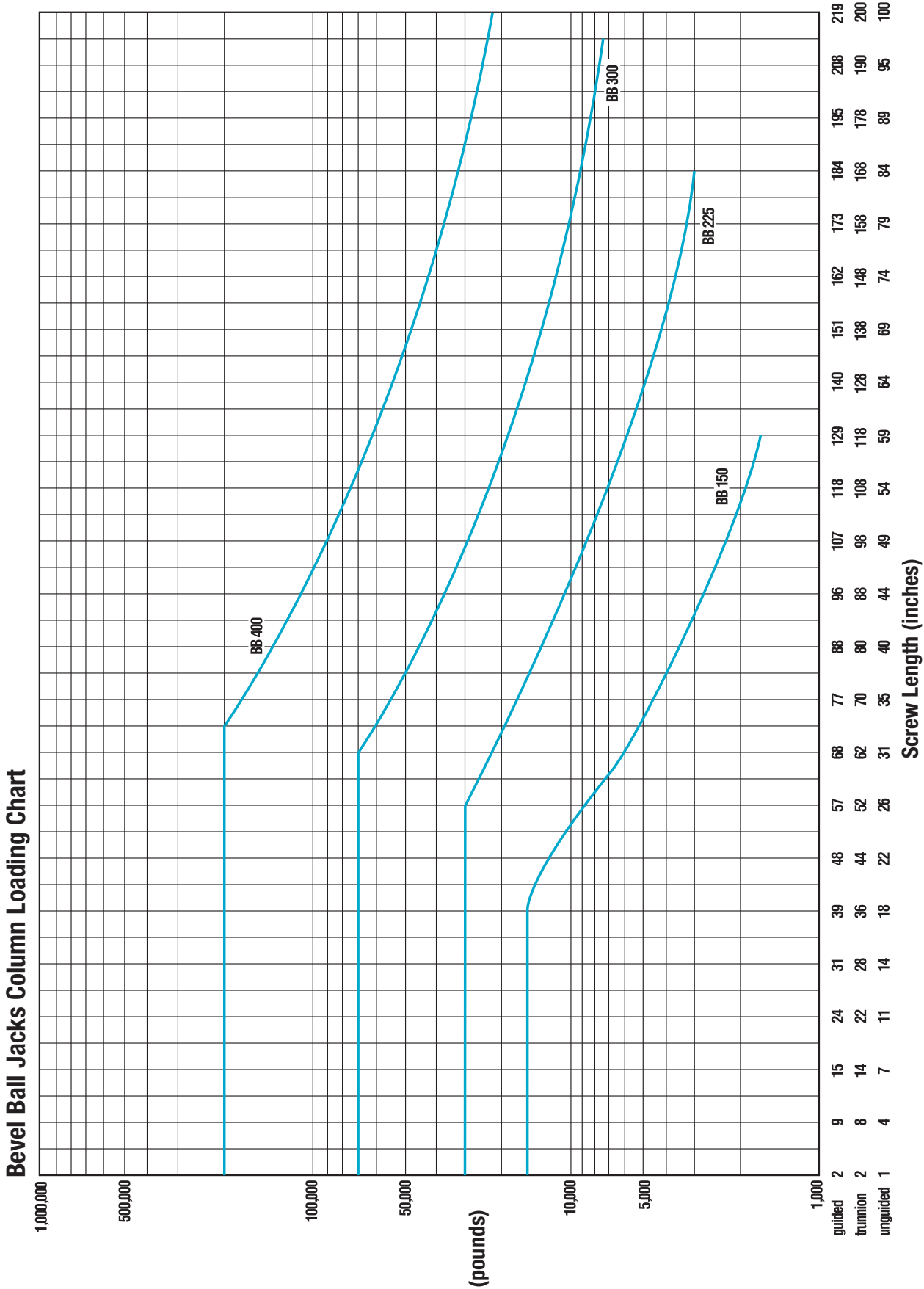

This chart includes a 2:1 Factor-of-Safety based on the Euler-Johnson equation for column loading (Oberg, Erik et al: Machinery's Handbook, 24th Edition. c. 1992 Industrial Press Inc.)
 The horizontal portion of each line represents the jack's maximum static capacity.

BEVEL GEAR BALL SCREW JACKS LIFE EXPECTANCY

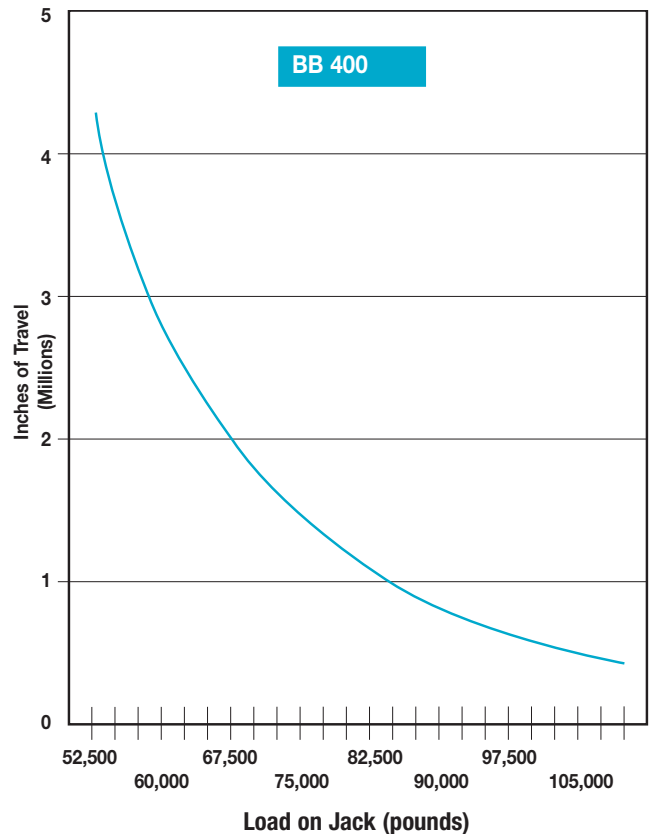
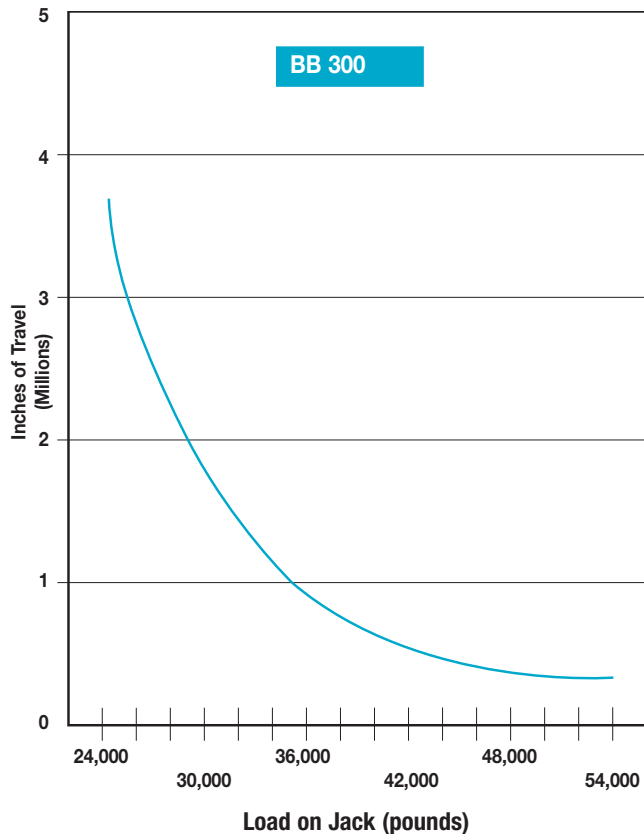
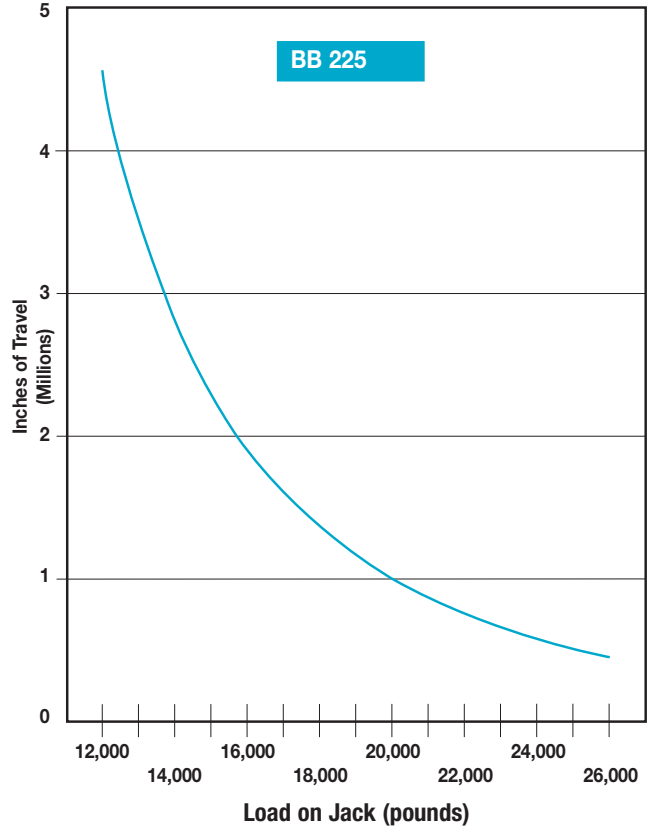
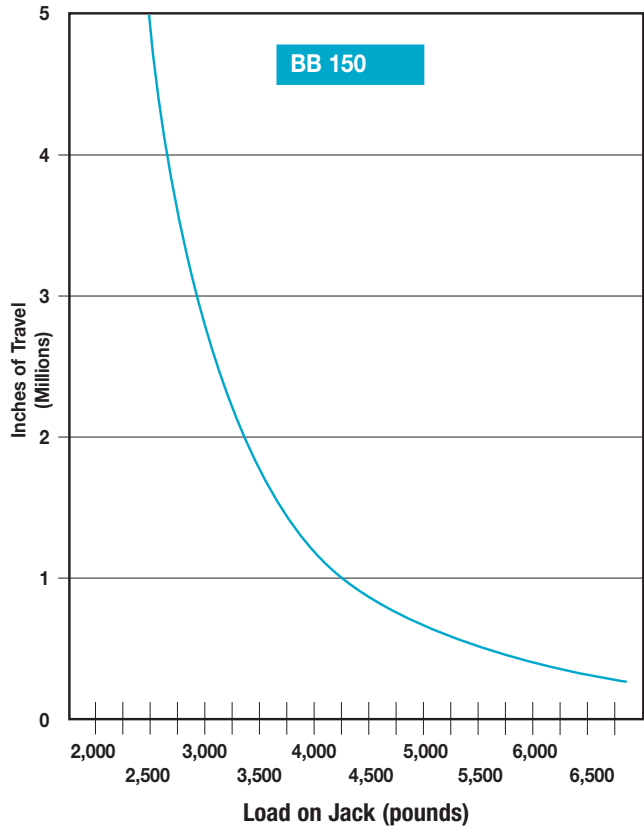

BEVEL GEAR BALL SCREW JACKS

BB 150 - 1 1/2" SCREW

Upright

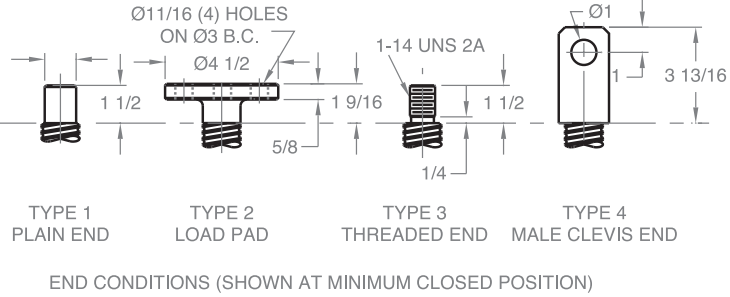
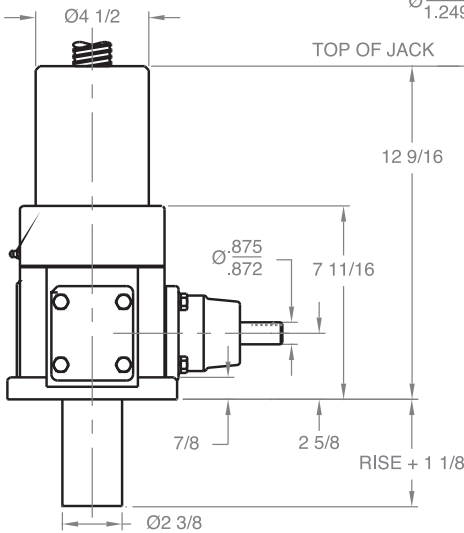

Upright traveling nut

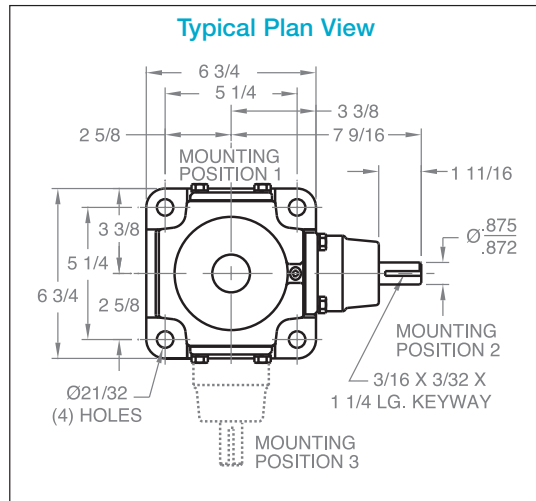
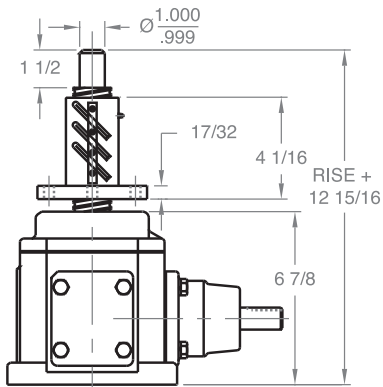

Inverted traveling nut

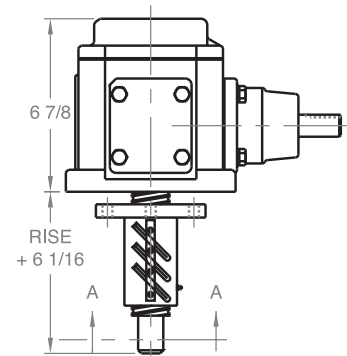

Inverted

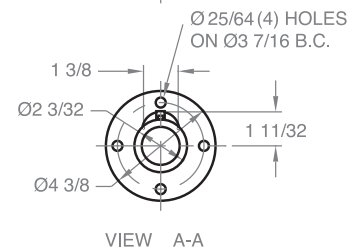
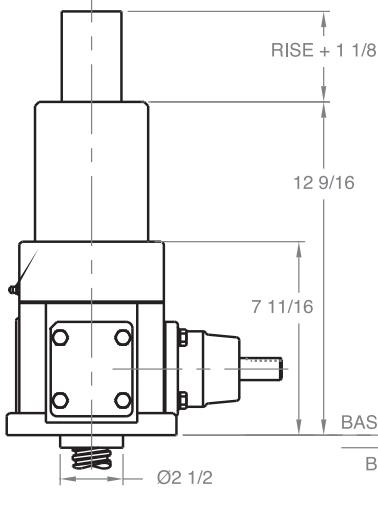

Note: Drawings are artist's conception — not for certification; dimensions are subject to change without notice.

BEVEL GEAR BALL SCREW JACKS

BB 225 - 2 1/4" SCREW

Upright

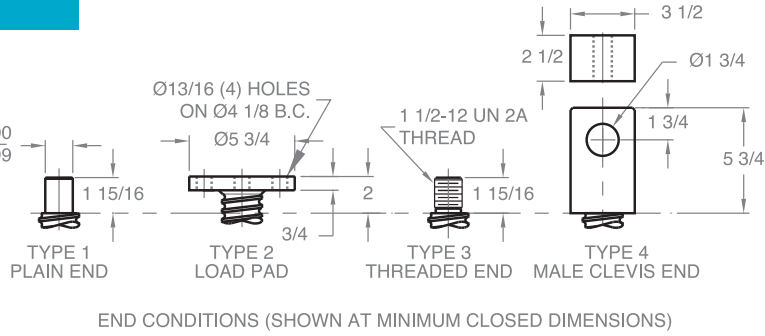
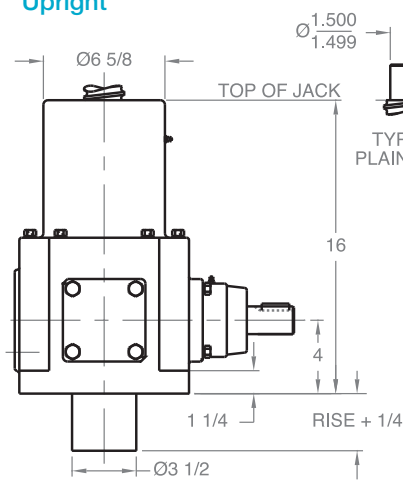

Upright traveling nut

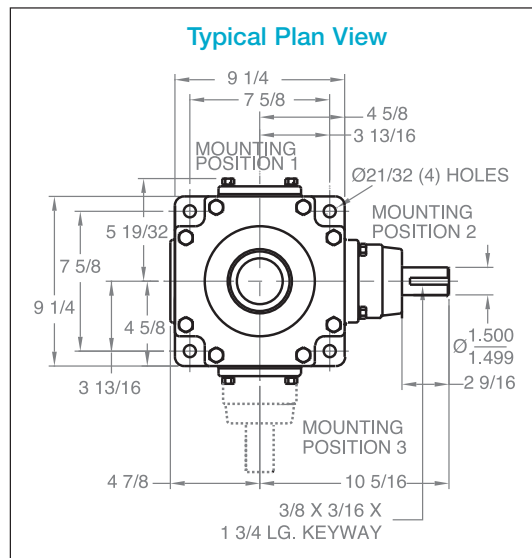
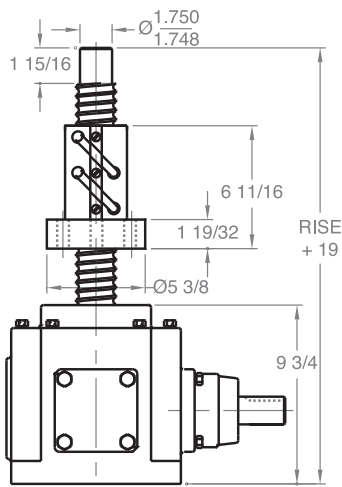

Inverted traveling nut

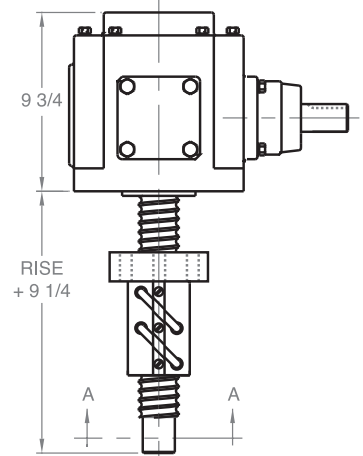

Inverted

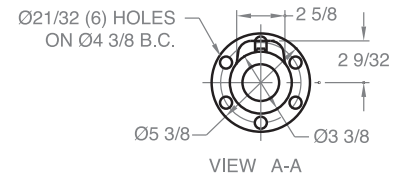
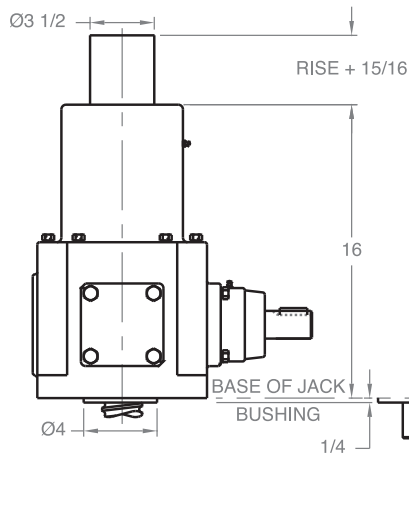

Note: Drawings are artist's conception — not for certification; dimensions are subject to change without notice.

BEVEL GEAR BALL SCREW JACKS

BB 300 - 3" SCREW

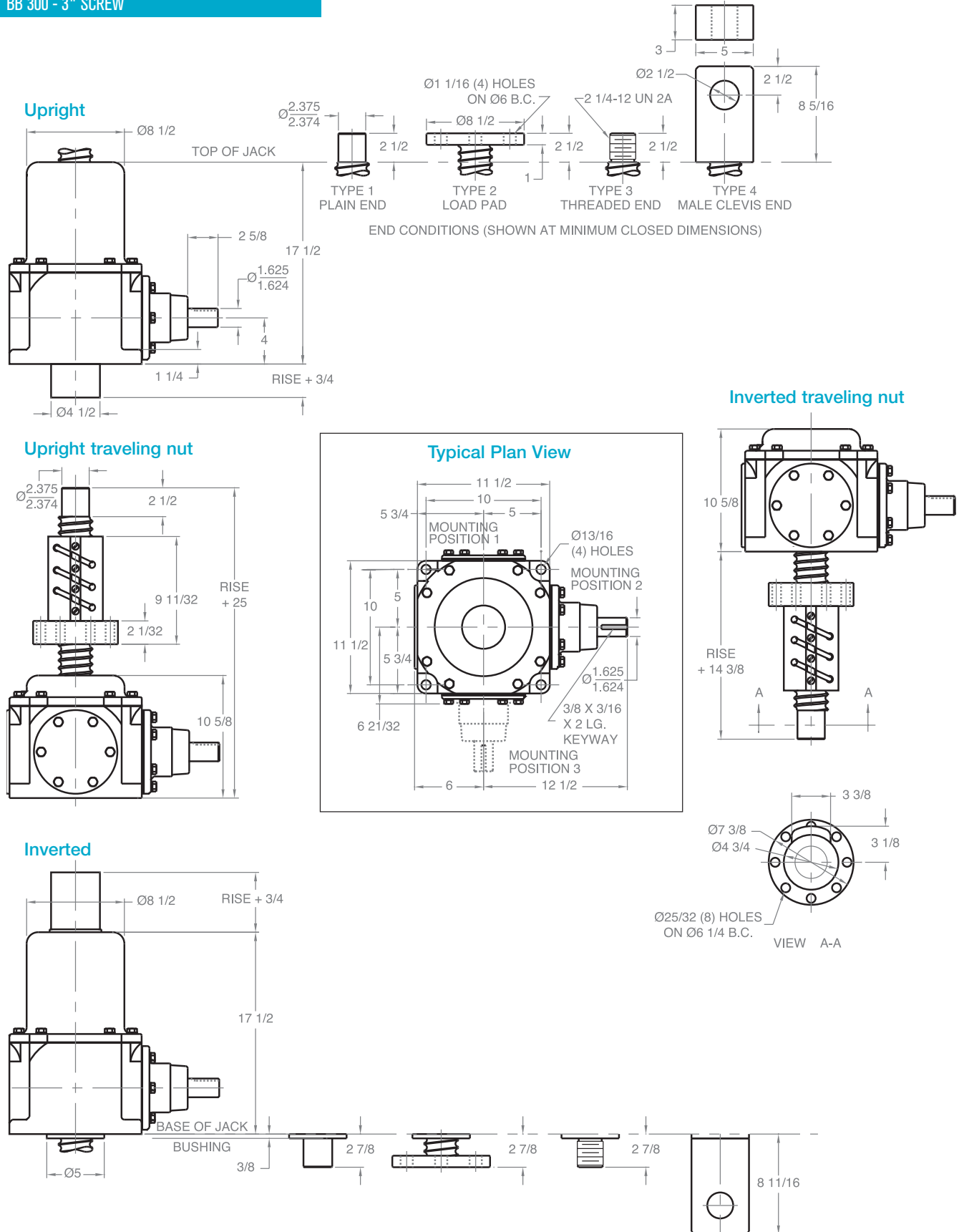

Note: Drawings are artist's conception — not for certification; dimensions are subject to change without notice.

BEVEL GEAR BALL SCREW JACKS

BB 400 - 4" SCREW

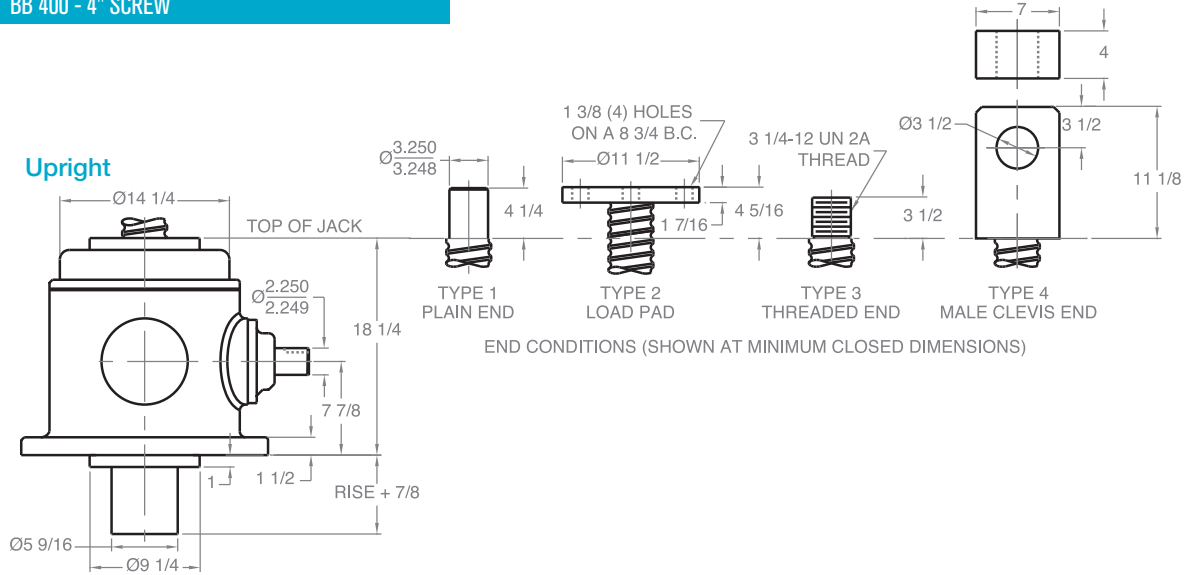

Upright traveling nut

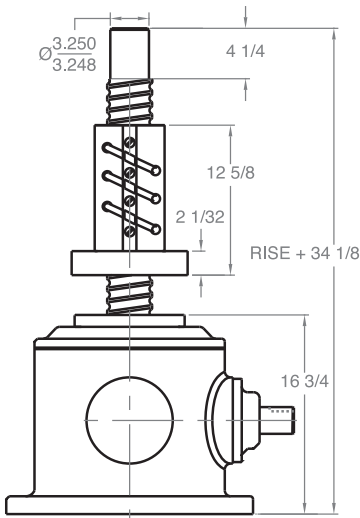

Typical Plan View

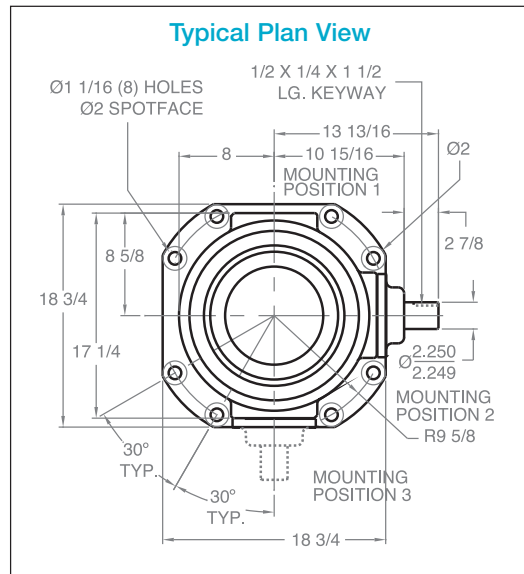

Inverted traveling nut

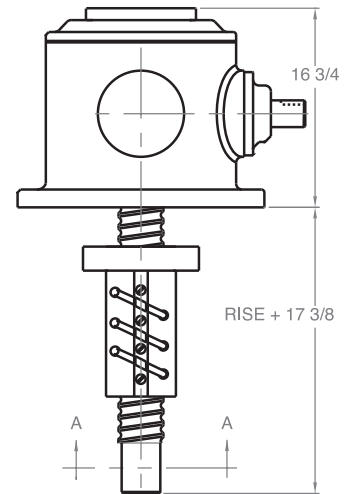

Inverted

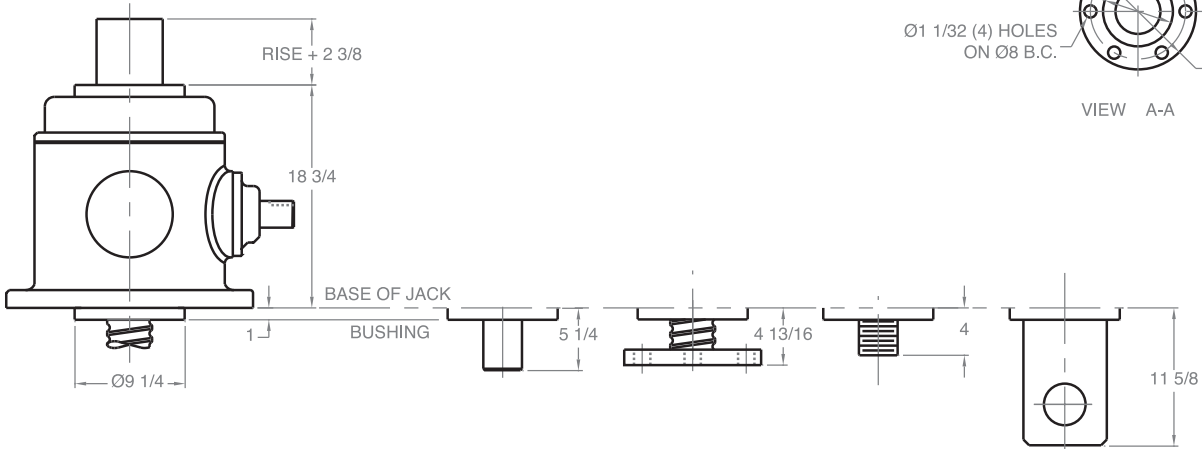

Note: Drawings are artist's conception — not for certification; dimensions are subject to change without notice.