

MACHINE SCREW JACK COMPONENT LIST

Note: When ordering supply the jack serial number along with the item number. Due to the multitude of components used by Joyce Dayton engineering will determine the associated part number.

Item	Part Description	Quantity
1	Sleeve	1
2	Thrust Bearing	2
3	Worm Gear	1
4	Sleeve Cap	1
5	Sleeve Cap Set Screws	4
6	Worm Shaft	1
7	Worm Shaft Bearing	2
8	Retaining Ring	2
9	Lifting Screw	1
10	Protection Tube	1
11	Bushing	1
12	Key	1
13	Key (KFTN)	1
14	Retaining Ring	1
15	Traveling Nut	1
16	Grease Fitting	1 to 3
17	Bellows Boot (optional - not shown on 100/150 Ton Model)	1
18	Bellows Boot Clamp (optional - not shown)	2
19	Worm Shaft Seal	2
20	Shims	2 to 6
21	Bearing Cap	2
22	Bearing Cap Lockwasher	6 to 16
23	Bearing Cap Screw	6 to 16
24	Key Screw	0 to 2
25	Base Plate	1
26	Protection Tube Adaptor/Bushing	1
27	O-Ring	1
28	V-Ring Seal (100/150 Ton Model Only)	2
29	Shims	1 to 3
30	Base Plate Screws	20
31	Dowel Pins	4
32	Set Screws	2
33	Keyed Cap (Not Sleeve Cap)	1
34	Keyed Cap Screws	6
35	Vent	1
36	Pipe Plug	1
37	Name Plate (not shown)	1
38	Name Plate Drive Screws (not shown)	2
39	Internal Seal (Stainless Steel Translating and Keyed)	2
40	Protection Tube Adaptor Bushing (SS Jacks)	1
41	Seal (SS KFTN Style Jacks)	1

100/150 Ton
Model Only

EXPLODED COMPONENTS VIEW - MODELS 250 LBS THRU 1 TON AND 10kN

(WJ250/500/1000, WJ51, WJ201, MWJ51, MWJ201)

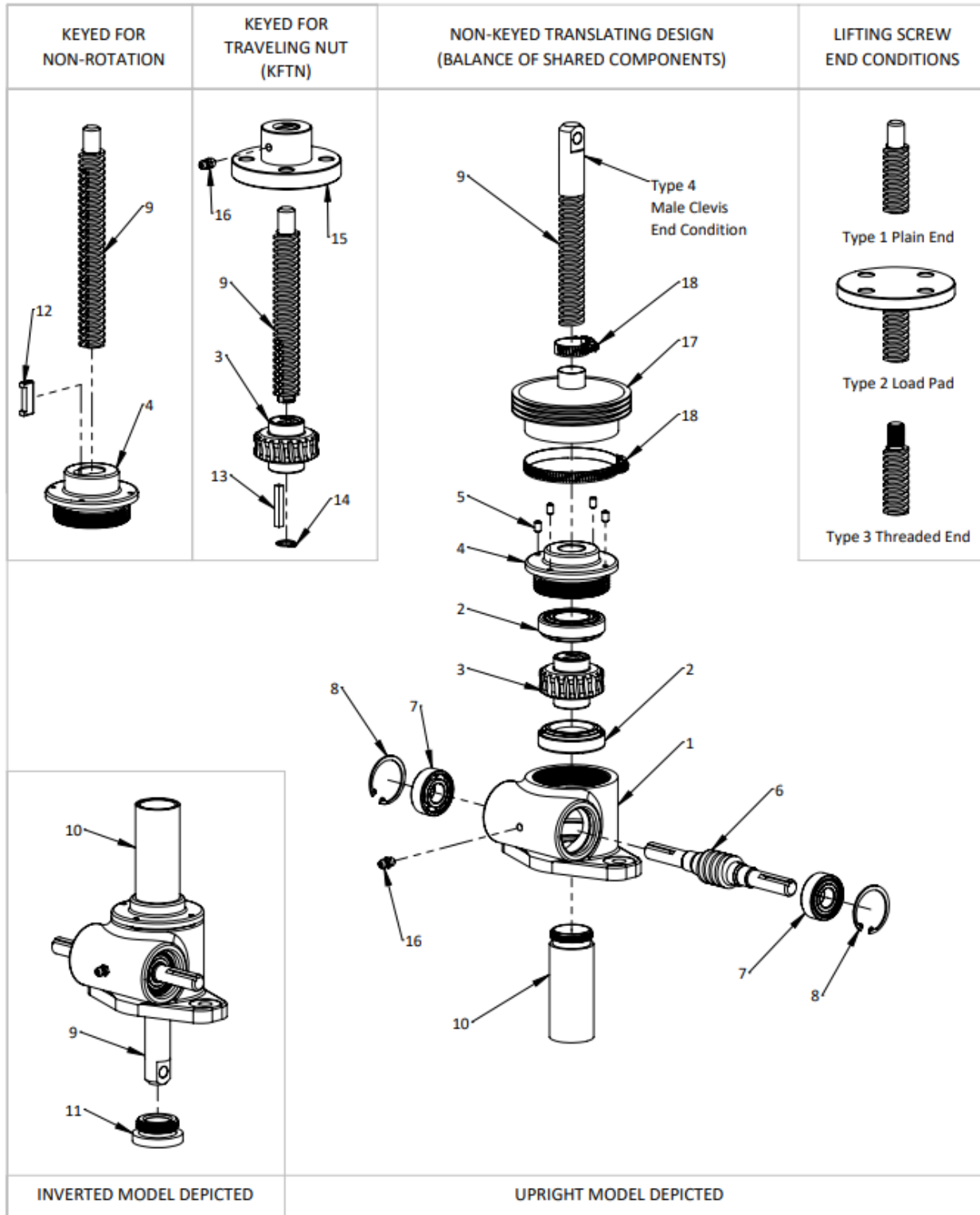

EXPLODED COMPONENTS VIEW - MODELS 2 THRU 75 TON - 25kN THRU 100kN

(WJ, WJT, RWJT, DWJ, DWJ, DRWJ, MWJ)

