

# MACHINE SCREW JACKS

250 POUND - 1/2" SCREW

WJ 250

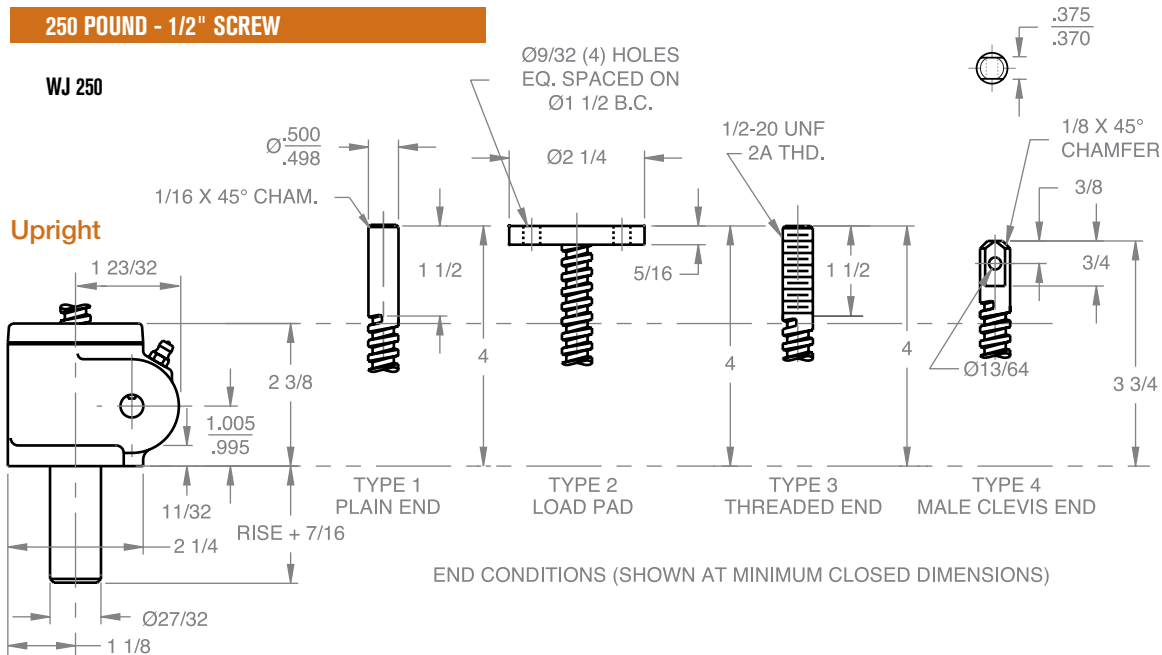

**Upright  
traveling nut**

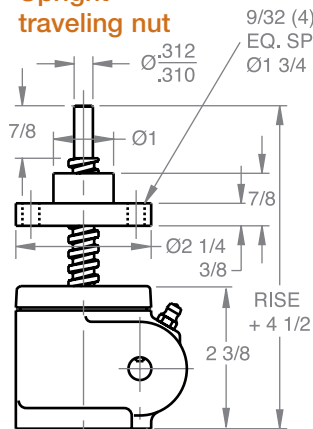

**Typical Plan View**

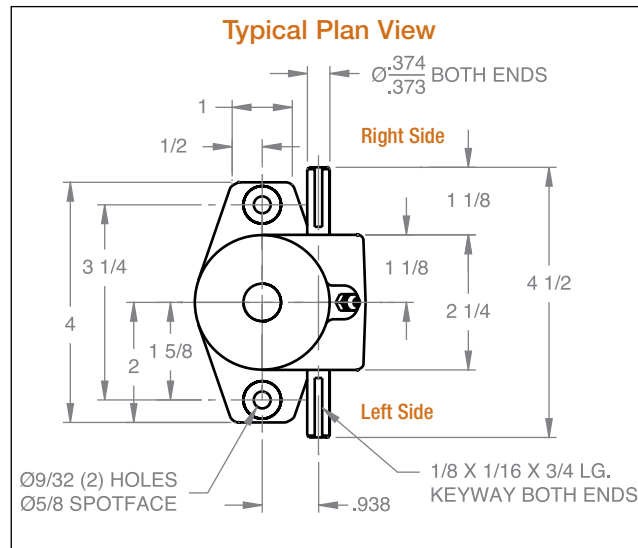

**Inverted  
traveling nut**

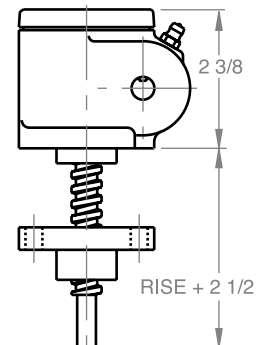

**Inverted**

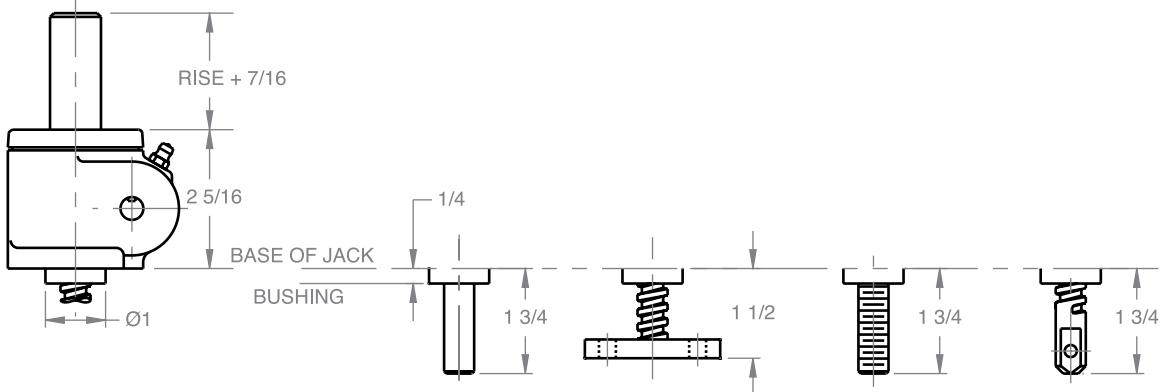

Material Notes: Housing and protection tube are aluminum. Lifting screw is 304 S.S., Input shaft (worm) is 416 S.S.

Note: Drawings are artist's conception — not for certification; dimensions are subject to change without notice.