

OPTIONS HAND WHEELS AND COUNTERS

| Hand Wheel Dimensions | | | | | | |
|----------------------------|-----------|------------------|------------------|------------------|-------------------|-------------------|
| Jack Capacity | Dimension | 4" Diameter HW04 | 6" Diameter HW06 | 8" Diameter HW08 | 10" Diameter HW10 | 12" Diameter HW12 |
| 250, 500 Lb. and 1,000 Lb. | A | 4 5/8 | 6 1/8 | | | |
| | B | 1 | 2 | | | |
| | C | 3/8 | 3/4 | | | |
| 1 Ton | A | 5 3/8 | 6 7/8 | 7 5/8 | 8 1/2 | 8 7/8 |
| | B | 1/2 | 1 1/2 | 2 1/2 | 3 1/2 | 4 1/2 |
| | C | 5/8 | 1 | 1 3/8 | 1 7/8 | 2 1/4 |
| 2 Ton Standard Base | A | 5 7/8 | 7 1/4 | 8 | 9 | 9 1/4 |
| | B | 1/4 | 1 1/4 | 2 1/4 | 3 1/4 | 4 1/4 |
| | C | 0 | 3/8 | 3/4 | 1 1/4 | 1 5/8 |
| 2 Ton Reverse Base | A | 5 3/4 | 7 1/4 | 8 | 9 | 9 1/4 |
| | B | 1/4 | 1 1/4 | 2 1/4 | 3 1/4 | 4 1/4 |
| | C | 1 3/4 | 2 1/8 | 2 1/2 | 3 | 3 3/8 |
| 2.5 Ton | A | 5 3/4 | 7 1/4 | 8 | 9 | 9 1/4 |
| | B | 1/4 | 1 1/4 | 2 1/4 | 3 1/4 | 4 1/4 |
| | C | 1 1/2 | 1 7/8 | 2 1/4 | 2 3/4 | 3 1/8 |
| 3 Ton | A | 5 3/4 | 7 1/4 | 8 | 9 | 9 1/4 |
| | B | 1/4 | 1 1/4 | 2 1/4 | 3 1/4 | 4 1/4 |
| | C | 1 1/2 | 1 7/8 | 2 1/4 | 2 3/4 | 3 1/8 |
| 5 Ton | A | 6 3/8 | 7 3/4 | 8 3/4 | 9 1/2 | 10 |
| | B | 0 | 3/4 | 1 3/4 | 2 3/4 | 3 3/4 |
| | C | 1 1/8 | 1 1/2 | 1 7/8 | 2 3/8 | 2 3/4 |
| 10 Ton | A | | | 9 3/8 | 10 1/4 | 10 5/8 |
| | B | | | 1 3/4 | 2 3/4 | 3 3/4 |
| | C | | | 1 7/8 | 2 3/8 | 2 3/4 |
| 15 Ton | A | | | 9 3/8 | 10 1/4 | 10 5/8 |
| | B | | | 1 1/4 | 2 1/4 | 3 1/4 |
| | C | | | 1 3/4 | 2 1/4 | 2 5/8 |
| 20 Ton | A | | | 9 3/8 | 10 1/4 | 10 5/8 |
| | B | | | 3/4 | 1 3/4 | 2 3/4 |
| | C | | | 1 1/2 | 2 | 2 3/8 |

Hand wheels are recommended for self-locking jacks. They are aluminum.

| Counter Dimensions | | | | | | | |
|--------------------|---------------|---------|-------|-------|--------|--------|--------|
| Dimension | Jack Capacity | | | | | | |
| | 2 Ton | 2.5 Ton | 3 Ton | 5 Ton | 10 Ton | 15 Ton | 20 Ton |
| D | 4 1/2 | 4 1/2 | 4 1/2 | 5 | 5 7/8 | 5 7/8 | 6 |

Standard count increases as lifting screw extends. Longer wormshafts are available, contact Joyce/Dayton.

Ordering information is found within specific product sections.

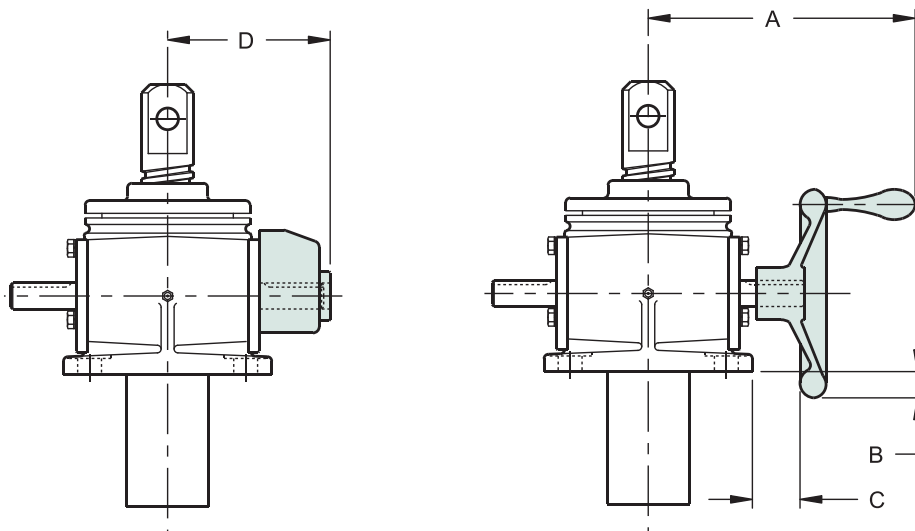

Note: Drawings are artist's conception — not for certification; dimensions are subject to change without notice.