

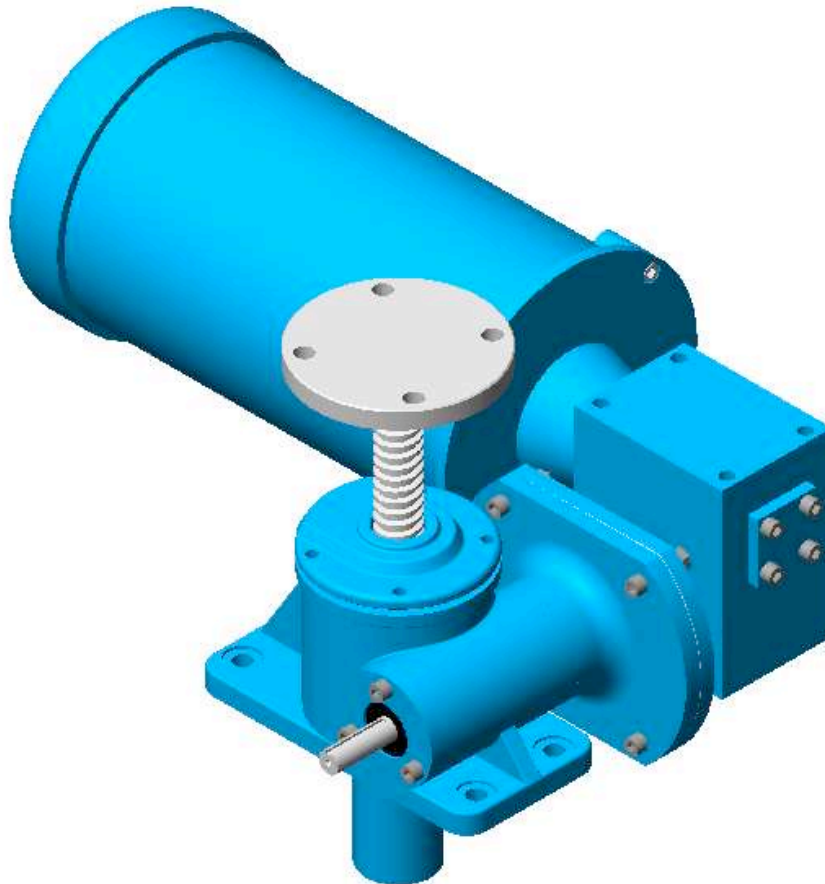

Joyce/Dayton Corp.

**Operation and Maintenance Manual for Joyce/Dayton
Machine Screw ComDRIVE® Actuators**



The recommendations in this manual for installation, operation and maintenance must be followed to ensure safe use. All persons responsible for the installation and use of Joyce ComDRIVE® actuators must be familiar with the contents of this manual.

The customer is responsible for travel stops, guards and other protective devices and ensuring that ComDRIVE® usage conforms with local and national operating and safety codes appropriate to the class of equipment into which the ComDRIVE® is installed. Series DCD ComDRIVES® are not self-locking. A brake motor or other external locking device must be provided.

Adjustable stop collars are included on standard ComDRIVE® actuators. The customer is responsible for providing travel limits.

Table of Contents

Section I – General Information

1-1 Contact Joyce Dayton Corp	2
1-2 Purpose and Scope	2
1-3 Receipt of Product	2
1-4 Warranty	2
1-5 Precautions of Use and Installation	3
1-6 General Installation Instructions	3

Section II – Maintenance

2-1 Lubrication	4
2-2 Repair Parts.....	5
2-3 Disassembly of ComDRIVE® jacks.....	5
2-4 Inspection of Components	6
2-5 Assembly of ComDRIVE® jacks	7

Section III – Views & Parts list

3-1 Exploded View	8
3-2 Parts list – Translating & KFTN ComDRIVES®	9
3-3 Maintenance Log and Serial Number	10

Section I General Information

1-1 Contact Joyce Dayton Corp.

Joyce Dayton Corp.
P.O. Box 1630
Dayton, OH 45401
(800) 523-5204 (US and Canada)
(937) 294-6261 (937) 297-7173 Fax
Email: sales@joycedayton.com
Website: www.joycedayton.com

1-2 Purpose and Scope

This manual provides installation, operation and maintenance instruction for standard Joyce/Dayton ComDRIVE® actuators. Although this manual covers the standard ComDRIVE® and most variations of the ComDRIVE®, there may be some that vary significantly from this manual. For special units not covered please contact Joyce/Dayton Corp. for assistance.

1-3 Receipt of Product

All equipment should be immediately inspected upon receipt for any damage and to verify correct product and quantities. Any problems should be reported to Joyce/Dayton Corp. and the freight carrier as soon as possible. Products returned without a *Return Goods Authorization (RGA)* form will not be accepted.

1-4 Warranty

Seller warrants its products to be free from defects in material and workmanship under normal and proper use in accordance with instruction of seller for a period of one year from the date of shipment to buyer. Seller's liability under such warranty or in connection with any other claim relating to the products shall be limited to the repair, or at seller's option, the replacement or refund of the purchase price, of any products or parts or components thereof which are returned to seller freight prepaid and which are defective in material or workmanship. Products or parts or components thereof, which are repaired or

replaced by seller, will be returned to buyer freight collect. This warranty is not intended to cover consumer products, as defined in the Magnuson-Moss Warranty-Federal Trade Commission Improvement Act, 15 U. S. C. Sections 2301-12, which are purchased by buyer for purposes other than resale. If buyer is not intending to resell the products, and if the products are consumer products as defined in the Magnuson-Moss Act, the foregoing warranty, but not the limitation of seller's liability, shall be null and void. EXCEPT AS EXPRESSLY STATED ABOVE, SELLER MAKES NO WARRANTY, EXPRESS OR IMPLIED, WHETHER OF MERCHANTABILITY OR FITNESS FOR ANY PARTICULAR PURPOSE OR USE OR OTHERWISE, ON THE PRODUCTS, OR ON ANY PARTS OR LABOR FURNISHED DURING THE SALE, DELIVERY OR SERVICING OF THE PRODUCTS.

1-5 Precautions of Use and Installation

1. Side loading of the lifting screw is not permitted in the dynamic operation of the jack. A limited side load is allowable in the static condition. Contact Joyce/Dayton for the allowable side load for a specific application.
2. Mechanical stops are provided on the actuator lifting screw. It is the customer's responsibility to provide travel limit devices on all ComDRIVEs®. A mechanical stop is only an auxiliary device to limit the travel of the lifting screw. Engaging a mechanical stop during operation can cause damage to the internal jack mechanism.
3. In most applications, factory or manufacturer-assisted installation is not required. However, it is necessary that appropriate, qualified personnel perform the installation of Joyce/Dayton products.
4. Joyce/Dayton ComDRIVE® actuators are not rated for shock-loading, extreme vibration or critical speed conditions (high speed or long-length screw.) It is the responsibility of the user to ensure these conditions are not imposed on the actuator or the power transmission equipment. Contact Joyce/Dayton for technical assistance.
5. In the event that service or maintenance is required, the load must be secured or removed before any work can begin.
6. The ComDRIVE® actuators can be mounted and operated in any orientation. When used with the lifting screw in a horizontal position, the worm should be mounted parallel with the horizon and below the gear to ensure proper lubrication. Standard ComDRIVE® actuators are shipped with all holes plugged. The user must insert the vent in the highest location at final installation.
7. Never allow the actuator to retract beyond the minimum closed position, as damage to the jack can occur.
8. Boots or protective bellows covers should be used to protect and keep the lifting screw clean in dusty or abrasive environments.
9. For continuous or high-duty cycles inquire with your local sales representative or consult Joyce/Dayton Corp. regarding Bevel Ball actuators.

1-6 General Installation instructions

1. Ensure that all personnel who will service or operate equipment are familiar with its use and limitations.
2. Secure or remove the load before any installation procedures begin.
3. Be certain the rating of the ComDRIVE® meets or exceeds the load.
4. The ComDRIVE® must be mounted on a structure sufficient to support the maximum possible load. The structure must be rigid. An under-designed structure could lead to bending of the lifting screw causing premature wear or failure.
5. In a system with shafts, miter boxes, etc., confirm that the shafts and actuators operate without binding or excessive force before powered drive devices are engaged. Drive shaft alignment is critical. Mis-alignment will cause reversing stresses in rotating members and will lead to fatigue failure. Correct coupling specification is important.
6. When fastening the load to an actuator, make sure the actuator is in the retracted position. This positions the load accurately with respect to the lifting screw centerline.

Never pull the screw to one side to make connection with your structure. Fully extend the actuator to make sure the load is aligned with the lifting screw.

7. All ComDRIVE® actuators are designed to be mounted with S.A.E. Grade 8 bolts or equivalent.
8. Torque all mounting bolts in a symmetric pattern to avoid damage to the sleeve.
9. Shaft and coupling guards are the responsibility of the user.
10. Optional limit switches furnished with the actuator are NOT preset and require field adjustment before use.

Section II Maintenance

2-1 Lubrication

Jacks

1. ComDRIVE® actuators are lubricated before leaving the factory.
2. For normal operation, jacks should be greased at least once per month. Under extended use, grease twice monthly or as conditions dictate. Grease thru the fittings on the jack with hand or power operated equipment. Grease with No. 1 Consistency Grease. Do not allow jacks to operate without lubrication. It is the responsibility of the user to maintain sufficient lubrication of the jack and to the lifting screw.
3. The products listed below are recommended by the lubricant manufacturers to meet the requirements for normal operation. The listing of brand names is solely for the convenience of users of Joyce equipment and their lubricant suppliers; it does not constitute any endorsement. Joyce/Dayton assumes no responsibilities for the quality, performance or availability of any listed products

<u>COMPANY</u>	<u>BRAND NAME</u>
Mobil Grease.....	XHP 461
Shell Oil Company.....	Retinax HD NLGI 1
Mobil Oil.....	Mobilith SHC PM 460

4. For operation above 250°F or extreme loading, consult the Engineering Department of Joyce/Dayton Corp.
5. Do not operate jack without lubrication.
6. Total grease capacity by jack type:

Jack Capacity	Number of Shots	Approximate Weight	Jack Capacity	Number of Shots	Approximate Weight
2 ton	13	4.5 oz	15 ton	50	17 oz.
3 ton	13	4.5 oz	20 ton	95	33 oz.
5 ton	26	9 oz	25 ton	140	49 oz.
10 ton	50	17 oz	30 ton	135	47 oz.

Reducers

1. Standard ComDRIVE reducers are lubricated before leaving the factory. The standard lubrication used in the reducers is AGMA 7 Compounded oil (ISO Grade 460).
2. The products listed below are recommended by the lubricant manufacturers to meet the requirements for normal operation. The listing of brand names is solely for the convenience of users of Joyce equipment and their lubricant suppliers; it does not constitute any endorsement. Joyce/Dayton assumes no responsibilities for the quality, performance or availability of any listed products.

<u>COMPANY</u>	<u>BRAND NAME</u>
Mobil Oil.	Mobil 600W Cylinder Oil
Mobil Oil.....	Mobil 85W100

3. Synthetic lubricants are also recommended, especially under severe service. These lubricants are more viscosity/temperature stable and provide service over a broad range of temperatures. These lubricants have a longer service life, require fewer oil changes and increase the life of the gearbox by reducing friction and wear. This lubricant is also compatible with nitrile seal material and alloy bronze gear material.

<u>COMPANY</u>	<u>BRAND NAME</u>
Mobil Oil.	Mobil SHC 634

4. The oil in the reducer must be maintained at the proper level. The reducer must be at rest when the oil level is checked.
5. In a new unit, the oil should be changed (or filtered) after four weeks (or 100 hours) of use. The case should be flushed with light oil to remove any foreign substances.
6. After the initial oil change, the oil should be changed once every 6 months or 2500 hours, whichever occurs first.
7. More frequent oil changes may be necessary when there are severe duty or dirty conditions present.
8. Special order speed reducers supplied with ComDRIVE® actuators may or may not be factory lubricated. In this case, a separate O&M can be provided for the special reducer.

2-2 Repair Parts

Repair parts may be obtained by calling Joyce/Dayton Customer Service at (800) 523-5204, (937) 294-6261, (937) 297-7371 (facsimile) or your local sales representative. When ordering repair parts, please supply the ComDRIVE serial number, located on the jack nameplate.

Recommended repair parts (for rebuild or spares, the following parts are recommended – see exploded view, page 8 and parts list on page 9)

- A. (2) Worm shaft bearing and race – Item # 11
- B. (1) Shim kit – Assortment of item # 12
- C. (2) Worm shaft seal – Item # 15 (2-ton and above)
- D. (1) Thrust bearing – Item # 2
- E. (1) Nut (Wormgear)– Item #3
- F. (1) Boot (if signs of wear are evident) – Item # 34
- G. (1) Worm - Item #10
- H. (1) Lifting screw - #7
- I. (1) Motor - #25
- J. (1) Gear Reducer - #20

2-3 Disassembly of ComDRIVE® Jacks

Remove the (4) bolts and washers (item #19 and 18) from the adapter/reducer f-flange (item #17). The reducer and motor can now be removed from the jack. The motor included with the ComDRIVE® is not user serviceable, however, it can be replaced. Replacement parts for the gear reducer can be obtained from Joyce/Dayton by contacting sales@joycedayton.com.

Use the appropriate disassembly procedure for the ComDRIVE® jack– if the lifting nut is outside the jack on the screw, it is a Keyed for Traveling Nut (KFTN) jack, (also called a “rotating screw” jack), otherwise the jack is a translating model or a keyed model. Handle machined parts with care, and maintain an “order of disassembly” to aid in re-assembly. Remove all couplings, screw support bearings, etc. before beginning disassembly.

Disassembly Procedure for KFTN (rotating screw) Models: see Figure 3-1

1. Remove the boot clamps (item #33) and collapse boots (item # 34) if the jack is equipped with boots. Remove the traveling nut (item # 35) from the screw.
2. Loosen the (4) set screws (item # 5) in the sleeve cap and remove the sleeve cap by rotating counter-clockwise (CCW.)
3. The screw assembly can now be removed from the jack sleeve. The screw assembly consists of the lifting screw (item # 7), the upper thrust bearing (item #2), the key (item # 36) and the wormgear (item # 3). First, the upper thrust bearing can be removed from the assembly exposing the worm gear nut. Next, the worm gear nut can be separated from the screw for replacement if necessary. (On inverted KFTN jacks it may be necessary to remove the screw first.)
4. Remove screws (item # 16) from the bearing cap (item # 13). Remove the worm shaft bearing cap and seals (item # 15) carefully to avoid damaging seals. Make sure keys have been removed first.
5. Carefully remove the shims (item #12) from the jack sleeve or bearing cap. NOTE: there will not necessarily be an equal quantity of shims per side. Keep track of the number and order of shims on each side of the jack.
6. Remove the worm bearings (item # 11). The cup may be press-fit and require the use of a dead-blow, plastic or other non-marring mallet to remove the worm (item # 10).

Disassembly Procedure for Translating and Keyed Models: see Figure 3-1

1. Remove the boot clamps (item # 33) and collapse the boot (item # 34) if equipped. On upright and inverted models, loosen the (4) set screws (item # 5) and remove the sleeve cap (item # 4) by rotating CCW.
2. Remove the protection tube (item #28) and check to see if the lifting screw has travel stops. This may require the use of a pipe wrench or strap wrench. If the jack has travel stops on the screw, these will need to be removed before the lifting screw is removed from the jack. If the jack does not have stops, the lifting screw can be removed by simply unthreading it from the wormgear.
3. Remove the thrust bearings (item # 2) and the wormgear (item # 3) from the sleeve. The bearing cones may be pressed onto the wormgear.
4. Keyed jacks have a keyway cut the length of the lifting screw (item # 7). The sleeve cap (item # 4) has a key (item # 31), which travels in the keyway and prevents rotation of the lifting screw. It is very important to prevent any side load on a keyed jack, as the key can cut into the lifting screw, and severely affect the life of the jack.
5. Remove screws, (item # 16) from the bearing caps (item # 13). Remove the bearing caps and seals (item # 15) carefully to avoid damaging seals. Make sure keys have been removed first.
6. Carefully remove the shims (item # 12) from the jack sleeve or bearing cap. NOTE: there will not necessarily be an equal quantity of shims per side. Keep track of the number and order of shims on each side of the jack.
7. Remove the worm shaft bearings (item # 11). The cups may be press-fit and require the use of a dead-blow, plastic or other non-marring mallet to remove the worm (item # 10).

2-4 Inspection of Components

1. Before any inspection, it will be necessary to completely clean all parts of the jack. Use caution with any machined or fragile part.
2. Inspect the cleaned sleeve (item # 1) and sleeve cap (item # 4) for any signs of stress or fracture, especially around the mounting bolt locations.
3. Inspect the worm (item # 10) and thrust bearings (item # 2) for any signs of brinelling, abrasive wear or spalling. Test for smooth, quiet operation of bearings.
4. Inspect bearing caps (item # 13) for any signs of stress.

5. Inspect the keyway on the worm (item # 10) and roll the worm on a flat surface to look for wobble in the shaft. Threads on the worm should not show an excessive buildup of bronze gear material.
6. Replace all seals when a complete disassembly is done.
7. Inspect Aluminum-Bronze wormgear (item # 3) for signs of excessive wear.
8. Check boots (item # 34) for wear or cracks
9. Inspect lifting screw (item # 7) for straightness.

2-5 Assembly of ComDRIVES®

1. Ensure that all bearings are packed with grease. Coat seals with light oil and put masking tape on keyways and other sharp surfaces to avoid seal damage.
2. Assembly of jack is reverse of the disassembly procedure. Make sure all bearings and seals seat properly. The bearing cap screws and sleeve cap should only be hand tightened initially. Some jacks may require the wormgear and thrust bearing be installed first, as they will not pass the worm, if already installed.
3. Tighten bearing cap bolts. Check the input shaft for excessive axial or lateral movement. If the input shaft feels loose remove shims, if it feels tight, add shims. Give the input shaft a solid blow on each end (in axial direction) with a soft mallet and re-check the feel. If it feels OK, continue to next step, otherwise continue adjusting the shims. This is a trial and error operation. The correct set-up has a solid feel without play (axial or lateral) and the input shaft rotates with an even, smooth but snug feel.
4. When jack is re-assembled, the thrust bearing pre-load needs to be set. Check by rotating the input shaft, while tightening the sleeve cap. Continue to check the rotation of the input shaft as sleeve cap is tightened. Use a dead-blow hammer on top of sleeve cap to help it seat. Tighten sleeve cap until it will not tighten further by hand.

Section III Views & Parts List

3-1 Exploded View

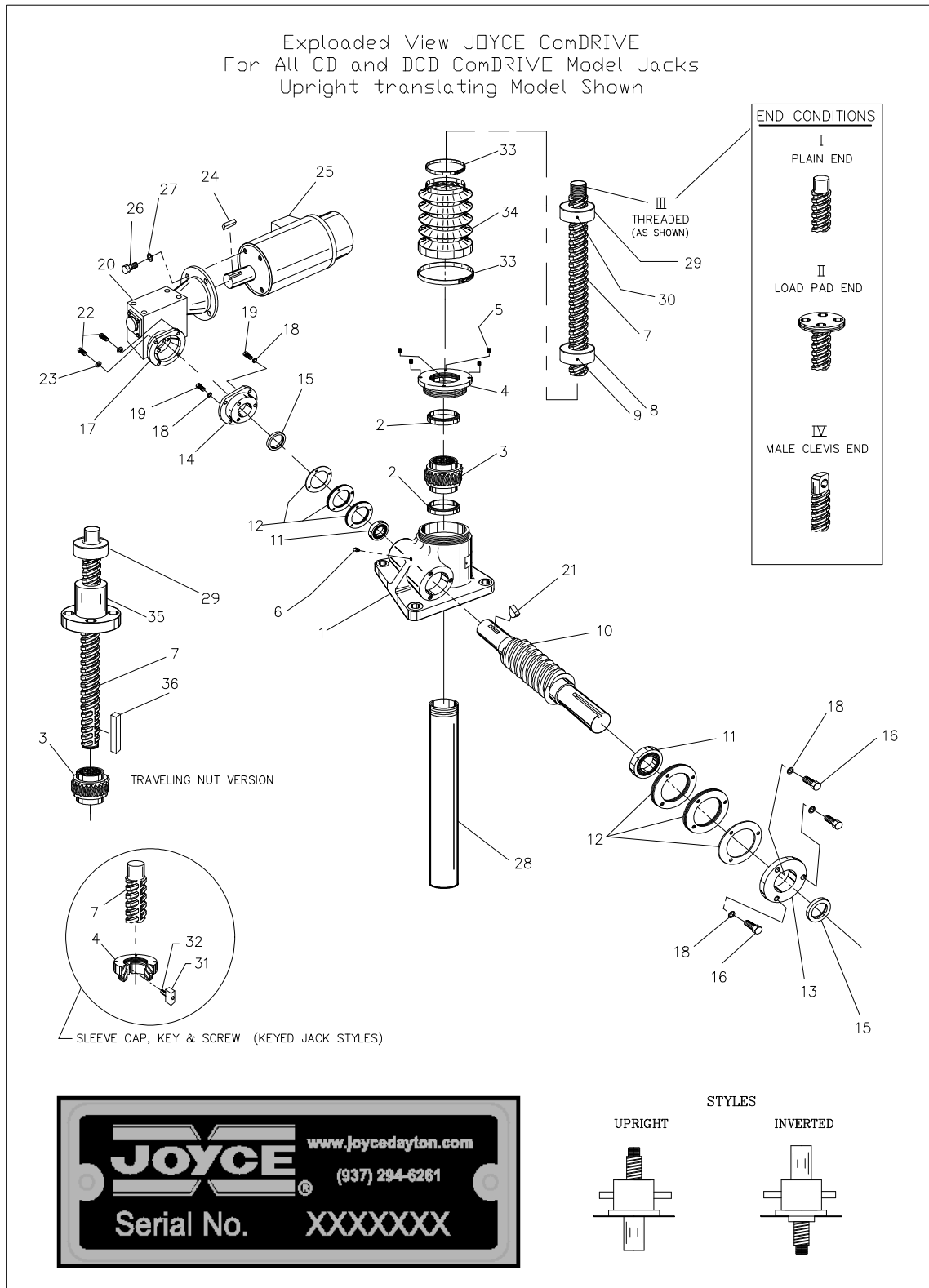

3-2 Parts List – Translating and KFTN ComDRIVES®

Table 3-2 Parts list

Item	Translating or Keyed for Non-rotation	Item	KFTN- Keyed For Traveling Nut
1	Sleeve	1	Sleeve
2	Thrust Bearing	2	Thrust Bearing
3	Nut (Wormgear)	3	Nut (Wormgear)
4	Sleeve Cap	4	Sleeve Cap
5	Sleeve cap set screw (4)	5	Sleeve cap set screw (4)
6	Grease Fitting	6	Grease Fitting
7	Jack Screw	7	Jack Screw
8	Screw Stop	8	-----
9	Pin or Set Screw	9	-----
10	Worm (Input Shaft)	10	Worm (Input Shaft)
11	Worm Shaft Bearing (2)	11	Worm Shaft Bearing (2)
12	Shims	12	Shims
13	Bearing Cap (1)	13	Bearing Cap (1)
14	Adapter Cap	14	Adapter Cap
15	Worm Shaft Seal (2)	15	Worm Shaft Seals (2)
16	Bearing Cap Screw (3-4)	16	Bearing Cap Screw (3-4)
17	Adapter	17	Adapter
18	Lock Washer (6-8)	18	Lock Washer (6-8)
19	Adapter Cap Screw (3-4)	19	Adapter Cap Screw (3-4)
20	Gear Reducer	20	Gear Reducer
21	Woodruff Key	21	Woodruff Key
22	Hex Head Cap Screws (3-4)	22	Hex Head Cap Screws (3-4)
23	Lock Washers	23	Lock Washers
24	Key – Motor Key	24	Key – Motor Key
25	Electric Motor	25	Electric Motor
26	Hex Head Cap Screws (3-4)	26	Hex Head Cap Screws (3-4)
27	Lock Washers (3-4)	27	Lock Washers (3-4)
28	Protection Tube	28	-----
29	Screw Stop (1)	29	Screw Stop (1) (upper collar)
30	Pin or Set Screw	30	-----
31	Key – keyed jacks	31	-----
32	Key Screw – keyed jacks	32	-----
33	Boot Clamp	33	Boot Clamp
34	Bellows Boot	34	Bellows Boot
35	-----	35	Traveling Nut
36	-----	36	Key - KFTN

3-3 Maintenance Log and Serial Number

Date	Maintenance Performed	Initials

Serial # _____



Contact Joyce/Dayton Corp. and provide the serial number to obtain product information needed for maintenance, repair and reorder.

Joyce/Dayton Corp
P.O. Box 1630
Dayton, Ohio 45401
Phone (800) 523-5204 (U.S. & Canada); (937) 294-6261 Fax (937) 297-7173
www.joycedayton.com E-mail: sales@joycedayton.com